

INSTALLATION and PARTS MANUAL (MODEL)

MODELS L5, L5A,
L5F, L5FA, 15F, 15FA
FROZEN FOOD
ICE CREAM

THIS REFRIGERATOR CONFORMS TO THE
COMMERCIAL REFRIGERATOR MANUFACTURERS ASSOCIATION
HEALTH AND SANITATION STANDARD
CRS-S1-67



WARREN // SHERER

DIVISION OF KYSOR INDUSTRIAL CORPORATION

1600 Rockdale Industrial Blvd., Conyers, Georgia 30207 (404) 483-5600

West Industrial Road, Marshall, Mich. 49068 (616) 781-3911

FROZEN FOOD MODELS L5 -L5F ELECTRIC DEFROST
 FROZEN FOOD MODELS L5A - L5FA AIR DEFROST
 ICE CREAM MODEL 15F - ELECTRIC DEFROST
 ICE CREAM MODEL 15FA AIR DEFROST

GENERAL	PAGE	CONDENSING UNITS	PAGE
Application	1	Size	2 -8
Cleaning	1	BTU Requirements	2 - 8
Drafts	1		
Waste Outlet.....	1		
Fans	1		
Fan Motors.....	1	ELECTRICAL	
Fan Blades	1	Connections	9 & 10
Ends	1	115 V. Circuits	9 & 10
Shelves	1	230 V. Circuits	9 & 10
Honeycomb	2	Temp. & Defrost Control	9 & 10
Air Velocities	2	Load Requirements	9 & 10
Light Ballasts	2	115 V. Heater & Fan	
Merchandising	2	Circuit Diagram	16,17,18, & 19
Health & Sanitation Stds.....	30,31, 32	230 V. Defrost Heater	
		Wiring Diagram	22,23,24, & 25
ASSEMBLY INSTRUCTIONS		3 Phase Case & Unit	
Two or more cabinets	3	Wiring Diagram w/def.kit	20 & 21
Joining instructions.....	27		
CONTROLS		REPAIR PARTS LIST	11 & 12
Tabulation	3		
Description	4		
REFRIGERATION		DIMENSION SHEETS	
Line Connection	4	End Views	13 & 14
Dehydration	4	Floor Plan	15
Suction Line Insulation	5		
Refrigerant	5		
Line Size	6,7, & 8		

C A U T I O N

BE SURE TO SEAL AROUND ALL OPENINGS AFTER CONNECTIONS ARE MADE.

Run No's.

APRIL, 1977

GENERAL INFORMATION

APPLICATION: These multiple shelf freezers were designed to merchandise food L5, L5F, L5A, L5FA and ice cream I5, I5FA. These freezers have been designed for use in air conditioned stores where temperatures and humidity are maintained at or below 75° dry bulb and not higher than 64° wet bulb (55° relative humidity).

CLEANING CASE: To insure minimum maintenance costs, cabinet should be thoroughly emptied and washed out every 3 months. A mild soap and water solution is recommended for enameled surfaces of the case. Do not use cleaner containing abrasive ingredients which will scratch or dull finish. The waste outlet should be flushed with a bucket of water following each cleaning. The two outer honeycombs should be inspected and cleaned as necessary every six months. Also see Page 2(Honeycomb).

DRAFTS: Drafts passing in front of freezer must be eliminated or operation will be seriously affected. Do not allow air conditioning grilles, electric fans, open doors or windows, etc. to create air currents past the cabinet in excess of 50 FPM.

WASTE OUTLET:

- LOCATION:** A 1" MPT drain tee is located at the front toe space at the center of the cabinet.
- WATER SEAL:** A line water seal is furnished with each cabinet, and should be installed as near the cabinet as practical. CAUTION - DO NOT allow a second water seal to be installed in series with the cabinet waste outlet furnished or cabinet will not drain properly.
- DRIP PIPE:** Drip pipe should have 1" in 4 ft. fall to insure rapid defrost water runoff.
- CLEANING:** Access to the waste outlet can be gained by removing the center bottom pans. The outlet is behind the fan panel and under the coil cover.
- CHECK:** Before putting cabinet in operation, check to be sure water will run completely from drain pan to floor waste outlet.

PANS: Access to the fans in the refrigerated circuit is obtained by removing the display bottom pans. The bottom fans in the guard circuit are accessible by removing the front panel. Second guard jet fans are accessible on top exterior of each cabinet.

FAN MOTORS: Fan motors require no oiling or maintenance of any kind and run continuously. (See Wiring Diagrams)

FAN BLADES: Fan blades are color coded. Be sure to replace blades with same color coding.

ENDS: Freezers are shipped with ends installed. CAUTION: Do not pry on bottom of ends when moving cases. This will damage ends and also break seal between ends and reezer.

SHELVES: Shelves are adjustable vertically in one inch increments.

HONEYCOMB: The honeycomb material located in the discharge air nozzles is fragile and care must be exercised to avoid damaging it. The honeycombs should be inspected and cleaned as needed after each 6 months of service.

SHELVES: Shelves are adjustable vertically as shown on end views Pages 13 & 14.

HONEYCOMB: The honeycomb material located in the discharge air nozzles is fragile and care must be exercised to avoid damaging it. The honeycombs should be inspected and cleaned as needed after each 6 months of service.

IMPORTANT: Personnel stocking these cabinets should be cautioned not to bump honeycomb when placing packages on the top shelf. Excessive accumulative damage to the honeycomb could result in faulty operation of the cabinet requiring replacement of the honeycomb.

Dirty or plugged honeycombs can easily be detected by using a Dwyer #460 Air Meter. Abnormally high readings for non-refrigerated honeycombs indicate that the honeycombs are dirty and should be cleaned. Generally refrigerated honeycombs will not require cleaning.

CAUTION: Before removing the guard duct honeycomb for cleaning, remove the three (3) plastic snap-on buttons located along the bottom edge of the nozzle. Buttons will damage honeycomb if they are not removed before honeycomb is removed. Honeycomb sections should not be interchanged from nozzle to nozzle or cabinet to cabinet, but must be replaced in the exact location that it was removed. (refer to Health and Sanitation instructions at the rear of this manual for correct procedure to remove honeycomb.)

AIR VELOCITIES: A "Dwyer" model #460 Air Meter must be used to measure the velocities as given below. Velocities are to be taken after the defrost cycle and once the cabinet is down to temperature.

<u>REFRIGERATED JET:</u>	760 F.P.M. Low Front Cabinets
	720 F.P.M. High Front Cabinets
<u>FIRST GUARD JET:</u>	560 F.P.M. High & Low Front Cabinets
<u>SECOND GUARD JET:</u>	500 F.P.M. High & Low Front Cabinets

LIGHT BALLASTS: Light ballasts for lights are located beneath the access panel on canopy. Access panel is held in place with sheet metal screws.

MERCHANDISE: Allow freezer to operate 4 to 5 hours before loading cabinet with merchandise. Merchandise should be kept in back of package stops and load line on all shelves. Package should be kept from covering return inlet in bottom compartment or operation will be impaired.

"CAUTION. In its condition as shipped and after proper installation, this equipment is not inherently dangerous. However, it is designed for connection to high voltage outlets and should, therefore, be installed only by a licensed electrician and in accordance with the instructions contained in this manual. A failure to follow these instructions might create an electrical condition (or other condition such as exposed metal edges, etc) hazardous to life or health. In particular be sure to seal around all openings after connections are made."

ASSEMBLING FREEZER

JOINING FREEZERS: Two or more cases may be joined to form a continuous line-up. Plexiglass dividers are required between cabinets when operated on separate condensing units. Instructions for joining two or more cabinets will be found in the joining kit box and also in this manual.

LEVELING Freezers must be located on a firmly based floor and carefully leveled within plus or minus 1/16" as checked at return ducts, using blocks or shims, if necessary. Check to be sure water will drain satisfactorily from cabinet before cabinet is put into operation.

CLEARANCE: If cases are to be located along an outside uninsulated wall, provisions should be made to ventilate or heat the dead air space between wall and case. If cases are located back to back, or if the end of case is adjacent to a wall or another fixture, the same provision for ventilation is necessary.

CONTROLS

<u>ITEM NO</u>	<u>CONTROL</u>	<u>LOCATION</u>	<u>ADJUSTMENT</u>
35	Temp. Control	L.H. End of cabinet canopy (on top)	-5 ° Cut-out (FF)
	Hi-Low Pressure	On Condensing unit	High 315 # (F502) Low 30 # Cut-in 0 # Cut-out
	Water Regulating Valve	On Condensing Unit	Adjust Valve to maintain 200-225# for F502
21	Expansion Valve (F502) (FF)	R.H. End of cabinet in coil compartment	Adjust to feed into heat exchanger
24	Oil Pressure	At Condensing Unit	Non-Adjustable
34	Defrost Termination Thermo-Disc.	11" FROM R. H. END (Behind 4" Plastic Cover)	Non-Adjustable (Set @45° ± 3)
(F 48	Defrost Relay	Behind Removable Lower Fan Panel	None

CONTROLS

TEMPERATURE CONTROL: The temperature control is located at the left hand end of canopy and is factory set at the approximate setting required for each cabinet. (Check control setting by thermometer even though control is set approximately.)

DEFROST CONTROLS (AIR DEFROST L5A MODELS)

If the cabinet is an L5A model which is an air defrost type, the defrost cycle is accomplished as follows:

1. At a preset time the time clock opens the condensing unit circuit and energizes the defrost relay which reverses the direction of the 1st. guard fans.
2. The condensing unit remains off until the coil temperature reaches the 45° setting. The thermo-disc closes activating the solenoid in the time clock which returns the cabinet to the refrigeration cycle. The relay coil is also deactivated which returns the 1st. guard fans to it original rotation.
3. The defrost timer is equipped with a fail-safe device which will terminate the defrost cycle in the event of a malfunction of the defrost termination control. A fail safe setting of 54 min. is recommended. The defrost time will vary from 21 min. with 55% R.H. Ambient to 48 min. with 15% R.H. ambient. This is due to the lower humidity air having less BTU per lb. of dry air (Enthalpy). It is therefore recommended that a fail safe of 54 min. be used to prevent the defrost from being terminated before the coil is free of frost.
4. Each cabinet has a thermo-disc which closes at 45° which is mounted on that back side of the back coil 11" from the right hand end. The thermo-discs of all cabinets using the same condensing unit must be wired in series.

DEFROST CONTROLS (ELECTRIC DEFROST L5 MODELS)

1. At a preset time the time clock opens the condensing unit circuit and energizes the defrost heaters.
2. The condensing unit remains off until the coil temperature reaches the 45° thermo-disc setting. The thermo-disc closes, activating the time clock solenoid which terminates the defrost heat and returns the cabinet to the refrigeration cycle.
3. Set the fail safe for 30 min. for electric defrosts.
4. Same as 4 under air defrost.
5. Defrost circuits are brought out of the cabinet and are connected as per the electrical diagram in the back of this manual.

DEFROST PERIODS:

Typical store conditions of less than 75° F - 55% R.H. normally requires 2 to 3 defrosts times per day.

More severe conditions may require up to 4 per day. Dry stores will require as few as one per day when on demand defrost controls.

OPERATING INSTRUCTIONS FOR DEFROST TIMER SETTING:

1. Place defrost pins in outer (24 hour) dial at 6-hour intervals. (55% or higher RH)
2. To set fail-safe (inside dial), push down and rotate pointer to desired setting.
3. To set time of day, grasp knob at center of inner dial and rotate it counter-clockwise. This will rotate the outer dial. Line up correct time of day on the outer dial with the time pointer. Rotate inner dial only. CAUTION: Install and operate in vertical position only and be sure all pins are tightened securely. Use screwdriver to tighten pins.

REFRIGERATION

REFRIGERATION CONNECTIONS: 1-1/8" suction and 3/8" liquid refrigeration lines terminate under the center bottom pans in the refrigerated circuit. These size lines can be extended for a distance of no more than 6 feet when connecting to the main. IMPORTANT: Seal around line after connections are made. (It is recommended that NITROGEN flow through the lines when making all sweat connections.)

DEHYDRATION: After the refrigeration system has been pressure tested and proven leak free it is recommended that the system be dehydrated with a high vacuum pump (capable of 1000 Microns or less) or using the triple evacuation method. The triple evacuation method requires evacuating the system three successive times and breaking each vacuum with dry refrigerant. Allow the pressure to rise above atmospheric pressure.

SUCTION LINE INSULATION: Insulate suction lines with at least 1/2" insulation of a type that will not absorb water.

REFRIGERANT: This freezer is operated on condensing units using R-502 refrigerant. The cabinet is furnished with R-502 expansion valve located at right hand end of the cabinet.

C.A.S. No.	LINE FEET HEAR	75° STORE B.T.U. REQ'D	COMPRESSOR SIZES (H.P.)			LINE SIZES						ELECTRICAL DATA			
			R-502			0'-50'		50'-100'		100'-150'				115v. Amps.	
			A	RA	W	S	L	S	L	S	L	Amps.	Amps.	Fan-Hrs.	Lights
1	8	10000	310	310	310	1-1/8	1/2	1-1/8	1/2	1-1/8	1/2			7.5	2.1
	12	15000	510	510	510			1-3/8		1-5/8				11.3	3.6
2	16	21200	560	560	510	1-3/8				1-5/8	5/8			15.0	4.2
	20	26500	700	700	760			1-5/8	5/8					18.8	5.7
	24	31800	790	790	760									22.6	7.2
	28	37100	1010	1010	790	1-5/8	5/8			2-1/8				26.3	7.8
1	32	42400	1510	1510	1010			2-1/8			7/8			30.1	9.3
	36	47700	1510	1510	1510									33.9	10.8

L5F-A 75°

AIR DRYING THE ENERGY SAVER

BTU BASED ON -25°F. SUCTION TEMP.

C.A.S. No.	LINE FEET HEAR	75° STORE B.T.U. REQ'D	COMPRESSOR SIZES (H.P.)			LINE SIZES						ELECTRICAL DATA			
			R-502			0'-50'		50'-100'		100'-150'				115v. Amps.	
			A	RA	W	S	L	S	L	S	L	Amps.	Amps.	Fan-Hrs.	Lights
1	8	12050	320	310	310	1-1/8	1/2	1-1/8	1/2	1-3/8	1/2			7.5	2.1
	12	18100	510	510	510			1-3/8		1-5/8				11.3	3.6
2	16	24100	560	560	560	1-3/8					5/8			15.0	4.2
1	20	30150	790	790	760			1-5/8	5/8					18.8	5.7
	24	36200	790	790	790	1-5/8	5/8			2-1/8				22.6	7.2
2	28	42200	1010	1010	1010			2-1/8			7/8			26.3	7.8
1	32	48250	1510	1510	1510									30.1	9.3
	36	54300	1510	1510	1510				7/8					33.9	10.8

L5-A 75°

BTU BASED ON -25°F. SUCTION TEMP.

- COMPRESSOR RECOMMENDATIONS ARE BASED ON STORES HAVING A MAXIMUM OF 75° WPTENT AND 55% R.H.
- THE A UNDER COMPRESSOR SIZES (H.P.) STANDS FOR AIR-COOLED; RA STANDS FOR REMOTE-AIR; W STANDS FOR WATER-COOLED.
- RISERS - IN THE SUCTION LINE ANY ELEVATION AS MUCH AS SIX FEET OR MORE MUST HAVE THE SUCTION LINE REDUCED TO THE NEXT SMALLER SIZE.
- EQUIVALENT LENGTH IS LENGTH FROM COMPRESSOR PLUS 4 FT. FOR EACH FITTING IN MAIN TRUNK LINE. USING THIS EQUIVALENT LENGTH, SELECT SIZE OF MAIN TRUNK FROM CHART ABOVE. FOR BRANCH LINES, REDUCE TO NEXT SMALLEST LINE SIZE FOR SECOND CASE; NEXT SMALLEST SIZE FOR THIRD CASE, ETC. ALWAYS MAINTAIN AT LEAST ONE SIZE LARGER THAN CASE OUTLET EXCEPT FOR REFRIGERATOR FURTHEST FROM COMPRESSOR. IT IS NOT NECESSARY TO RUN THE LARGE TUBING INTO REFRIGERATOR ITSELF, MERELY TO THE TUBING ENTRANCE.

STORE NO.	LINE FEET	75° STORE BTU REQ'D	COMPRESSOR SIZES (H.P.)			LINE SIZES						ELECTRICAL DATA			
			R-502			0'-50'		50'-100'		100'-150'		Defrost amps.		115v. amps.	
			A	RA	W	S	L	S	L	S	L	230V.-1φ	208V.-3φ	Fan Htr.	Lights
										Amps.	Amps.	Amps.	Amps.		
	8	10600	510	510	510	1-1/8	1/2	1-1/8	1/2	1-1/8	1/2		13.6	7.9	2.1
1	12	15200	510	510	510			1-3/8		1-3/8			20.4	11.9	3.6
	16	21200	560	560	510	1-3/8				1-5/8	5/8		27.2	15.8	4.2
1	20	26300	760	760	760			1-5/8	5/8				34.0	19.8	5.7
2	24	31800	790	790	760								40.8	23.8	7.2
1	28	37100	1010	1010	790	1-5/8	5/8			2-1/8			47.6	27.7	7.8
2	32	42400	1510	1510	1010			2-1/8			7/8		54.4	31.7	9.3
3	36	47700	1510	1510	1510								61.2	35.7	10.8
2	40	53000	1510	1510	1510				7/8				68.0	39.6	11.1

L5F 75°

BTU BASED -25°F. SUCTION TEMP.

STORE NO.	LINE FEET	75° STORE BTU REQ'D	COMPRESSOR SIZES (H.P.)			LINE SIZES						ELECTRICAL DATA			
			R-502			0'-50'		50'-100'		100'-150'		Defrost amps.		115v. amps.	
			A	RA	W	S	L	S	L	S	L	230V.-1φ	208V.-3φ	Fan Htr.	Lights
										Amps.	Amps.	Amps.	Amps.		
1	8	12050	510	510	510	1-1/8	1/2	1-1/8	1/2	1-3/8	1/2		13.6	7.9	2.1
	12	18100	510	510	510			1-3/8		1-5/8			20.4	11.9	3.6
2	16	24100	560	560	560	1-3/8					5/8		27.2	15.8	4.2
1	20	30150	790	790	760			1-5/8	5/8				34.0	19.8	5.7
	24	36200	790	790	790	1-5/8	5/8			2-1/8			40.8	23.8	7.2
2	28	42200	1010	1010	1010			2-1/8			7/8		47.6	27.7	7.8
1	32	48250	1510	1510	1510								54.4	31.7	9.3
	36	54300	1510	1510	1510					7/8			61.2	35.7	10.8
2	40	60300	2010	2010	2010								68.0	39.6	11.1

L5 75°

BTU BASED -25°F. SUCTION TEMP.

1. COMPRESSOR RECOMMENDATIONS ARE BASED ON STORES HAVING A MAXIMUM OF 75° AMBIENT AND 55% R.H.
2. THE A UNDER COMPRESSOR SIZES (H.P.) STANDS FOR AIR-COOLED; RA STANDS FOR REMOTE-AIR; W STANDS FOR WATER-COOLED.
3. RISERS - IN THE SUCTION LINE ANY ELEVATION AS MUCH AS SIX FEET OR MORE MUST HAVE THE SUCTION LINE REDUCED TO THE NEXT SMALLER SIZE.
4. EQUIVALENT LENGTH IS LENGTH FROM COMPRESSOR PLUS 4 FT. FOR EACH FITTING IN MAIN TRUNK LINE. USING THIS EQUIVALENT LENGTH, SELECT SIZE OF MAIN TRUNK FROM CHART ABOVE. FOR BRANCH LINES, REDUCE TO NEXT SMALLEST LINE SIZE FOR SECOND CASE; NEXT SMALLEST SIZE FOR THIRD CASE, ETC. ALWAYS MAINTAIN AT LEAST ONE SIZE LARGER THAN C/SZ OUTLET EXCEPT FOR REFRIGERATOR FURTHEST FROM COMPRESSOR. IT IS NOT NECESSARY TO RUN THE LARGE TUBING INTO REFRIGERATOR ITSELF, MERELY TO THE LUBING ENTRANCE.
5. DEFROST VOLTS: FOR 208V/1 PHASE, MULTIPLY 230V. AMPS BY 0.9. FOR 220V/1 PHASE, MULTIPLY 230V. AMPS BY 0.95.

-7-

REV 4/15/77

CASE	LINE FEET	75° STORE BTU REQ'D	COMPRESSOR SIZES(hp)			LINE SIZES						ELECTRICAL DATA			
			R-402			0-50'		50-100'		100-150'		Defrost amp. 115v.		amps	
			A	RA	W	S	L	S	L	S	L	amps	amps	amps	amps
1	8	13500	760	760	510	1-3/8	1/2	1-3/8	1/2	1-5/8	1/2			9.3	2.1
	1	20250	790	790	760			1-5/8			5/8			14.0	3.6
2	16	27000	1510	1510	1010	1-5/8			5/8	2-1/8	7/8			18.6	4.2
1	1	33750	1510	1510	1510		5/8	2-1/8						23.3	5.7
	2	40500	2010	2010	2010	2-1/8								28.0	7.2

COMPONENTS	8'		12'	
	TOTAL AMPS	VOLTS	TOTAL AMPS	VOLTS
FAN MOTORS	3.2	115	4.8	115
ANTI-SWEAT HEATERS	6.1	115	9.2	115
LIGHTS	2.1	115	3.6	115

15F-A 75°

BTU BASED ON -40°F. SUCTION TEMP.

Air-Defrost
ICE CREAM

- 3/8 O.D. LIQUID CONNECTION
- 1-1/8 O.D. SUCTION CONNECTION

CASE	LINE FEET	75° STORE BTU REQ'D	COMPRESSOR SIZES(hp)			LINE SIZES						ELECTRICAL DATA			
			R-402			0-50'		50-100'		100-150'		Defrost amp. 115v.		amps	
			A	RA	W	S	L	S	L	S	L	amps	amps	amps	amps
1	8	13500	760	760	510	1-3/8	1/2	1-3/8	1/2	1-5/8	1/2		16.6	9.3	2.1
	1	20250	790	790	760			1-5/8			5/8		24.9	14.0	3.6
2	16	27000	1510	1510	1010	1-5/8			5/8	2-1/8	7/8		33.2	18.6	4.2
1	1	33750	1510	1510	1510		5/8	2-1/8					41.5	23.3	5.7
	2	40500	2010	2010	2010	2-1/8							49.8	28.0	7.2

COMPONENTS	8'		12'	
	TOTAL AMPS	VOLTS	TOTAL AMPS	VOLTS
FAN MOTORS	3.6	115	5.4	115
ANTI-SWEAT HEATERS	6.1	115	9.2	115
LIGHTS	2.1	115	3.6	115
DEFROST HEATERS THREE PHASE	16.6	208	24.9	208

15F 75°

BTU BASED ON -40°F. SUCTION TEMP.

ELECTRIC DEFROST
ICE CREAM

- 3/8 O.D. LIQUID CONNECTION
- 1-1/8 O.D. SUCTION CONNECTION

ELECTRICAL

All electrical connections are made in the end to end wireway. To obtain access to this wireway the front lower panel must be removed.

115-VOLT CIRCUITS: (Single Phase)

Three (3) 115 Volt circuits terminate in the wireway. One circuit each provided for the lights, anti-sweat heaters and fans.

208-VOLT CIRCUITS: (FOR ELECTRIC DEFROST MODELS)

Defrost leads terminate in the wireway. Each lead is identified. Connect according to wiring diagram furnished.

208 VOLT CIRCUITS (FOR AIR DEFROST MODELS)

Two wires must be brought from the time clock terminals 3 & N (814S-20) and connected to the coil in relay DR5AY0 which will reverse the 1st. guard fan motors during defrost.

TEMPERATURE AND DEFROST CONTROL

Leads from the temperature control (used for cycling condensing units) and leads from defrost control (termination defrost) and also brought into the lower wireway and are identified with tags.

FROZEN FOOD ELECTRICAL REQUIREMENTS

L5 -L5F - L5A - L5FA

	L5 - L5F			L5A - L5FA		
		WATTS	AMPS		WATTS	AMPS
-115/60/1 ANTI-SWEAT HEATERS	8ft.	494	4.3		494	4.3
	12ft.	747	6.5		747	6.5
FANS	8ft.	274	3.6		266	3.2
	12ft.	411	5.4		399	4.8
LIGHTS (HO)	8ft.	243	2.1		243	2.1
	12ft.	405	3.6		405	3.6
208/60/3 DEFROST HEATERS	8ft.	4900	13.6	--	--	--
	12ft.	7350	20.4	--	--	--

(ICE CREAM ELECTRICAL REQUIREMENTS 15E 15FA)

	115/60/1		208/60/3	
	WATTS	AMPS	WATTS	AMPS
Anti-sweat Heaters	753	7.97 (8')		
	1158	9.7 (12')		
Fans	306	4.0 (8')		
	459	6.0 (12')		
Lights	243	2.10 (8')		
	405	3.60 (12')		
Defrost Heaters			6000	16.6 (8')
			9000	24.9 (12')

REPAIR PARTS FOR FROZEN FOOD & ICE CREAM MODELS WITH ELECTRIC DEFROST.

<u>ITEM NO.</u>	<u>PART NAME</u>	<u>PART NO.</u>	<u>DESCRIPTION</u>
<u>CONTROLS</u>			
34	Thermo-disc	3-014-02-0659	14T32-F45
35	Temperature Control (for cycling)	3-014-02-0804	Penn A19AAA-1
<u>DEFROST HEATERS (230 VOLT) L5 - L5F Frozen Food</u>			
8	COIL-CALROD	3-016-04-2305 Straight	(1) 2000 Watts (8ft.)
		3-016-04-3204 Straight	(1) 3000 Watts (12ft.)
		3-016-04-2404 Hairpin	(2) 2000 Watts (8ft.)
		3-016-04-3105 Hairpin	(2) 3000 Watts (12ft.)
<u>DEFROST HEATERS (230 Volts) 15F Ice Cream</u>			
8	COIL CALROD	3-016-04-2503 Straight	(1) 2450 Watts (8ft.)
		3-016-04-3501 Straight	(1) 3675 Watts (12ft.)
		3-016-04-2602 Hairpin	(2) 2450 Watts (8ft.)
		3-016-04-3600 Hairpin	(2) 3675 Watts (12ft.)
<u>REPAIR PARTS LIST FOR FROZEN FOOD & ICE CREAM MODELS</u>			
<u>L5 -L5F- L5A - L5FA -15F -15FA</u>			
<u>FANS</u>			
*36	Motor (Morrill)	3-015-03-1606	*SPB-6EVI (ref.&guard
36A	Motor	3-015-03-2554	MDD-1931V (1st. g Air Defrost Only.
37	7" Refrigerated Jet Fan Blades	3-015-01-1004	FV700CW-40S (color
38	7" Second Guard Jet Fan Blades	3-015-01-0808	FV700CW-20S (color go
37	7" First Guard Jet Fan Blades	3-015-01-1004	FV700CW-40S (color vie
<u>ANTI-SWEAT HEATERS (115 Volts)</u>			
40	Nozzle	2-265-00-0055	83 Watts .72 Amps. (8ft.)
		2-265-00-0063	125 Watts 1.09 Amps. (12ft.)
12	Honeycomb LH Heater	1-216-00-0032	115 Watts 1.0 Amps.
12	Honeycomb Center Heater	1-216-00-0032	115 Watts 1.0 Amps.
13	Honeycomb RH Heater	1-216-00-0032	115 Watts 1.0 Amps.
15	Return Grille Heater	2-200-00-0095	121 Watts 1.05 Amps. (8ft.)
		2-200-00-0103	187 Watts 1.62 Amps. (12ft.)
44	Return Duct Heater Ice Cream Model Only	2-275-00-0376	98 Watts .85 Amps. (12ft.)
		2-275-00-0384	74 Watts .64 Amps. (8ft.)
46	Display Liner Top Overlay Panel I.C. Model Only	2-240-00-0634	49 Watts .5 Amps. (8ft.)
		2-240-00-0642	88 Watts .8 Amps. (12ft.)
47	Wireway Heater	3-016-04-0101	60 Watts .5 Amps. (8ft.)
		3-016-04-0200	90 Watts .8 Amps. (12ft.)

*Substitute motors: Any G.E. or Redmond that is a unit bearing motor 115 volt 6 watt output, and clockwise rotation.

REPAIR PARTS LIST FOR FROZEN FOOD & ICE CREAM (cont'd)

<u>ITEM NO.</u>	<u>PART NAME</u>	<u>PART NO.</u>	<u>DESCRIPTION</u>
16	<u>HONEYCOMB</u> All Jets	3-019-05-0107	1/8" cell, 1 Mill Alum
	<u>LIGHTS</u>		
18	Ballast	3-016-01-4056	Univ. 480 XLHTCP or G.E. 8G3732
19	LAMPS General Electric, Sylvania, or Westinghouse	3-016-07-3805 3-016-07-3201	F96/T12/CWX/HO 8 ft. F72/T12/CWX/HO 12 ft.
49	Lamp Shield	3-019-08-1151	TP472S w/end caps (12 ft.) TP625S w/end caps (8 ft.)
24	Oil Pressure Safety Switch	3-016-28-1309	Penn P45NCA-12
25	Thermometer	3-033-08-0502	Glass Stem
41	Second Jet Fan Guard	1-205-00-0050	Expanded Metal
30	Heat Exchanger	3-011-04-0502 3-011-04-0403 3-011-04-0502	B500XS (12ft. F.F.) B200XS (8ft. F.F.) B500XS (8 & 12ft. I.C.)
32	3" Plastic Plug Buttons (white)	3-025-11-0101	Refrigerated Comp't.
	4" Plastic Plug Buttons (white)	3-025-11-0200	Refrigerated Comp't.
33	Lamp Holders	3-016-06-1404 3-016-06-1503	505X91 or 464 505X92 or 465 White
	<u>RELAY AIR DEFROST MODEL</u>		
48	Defrost Relay	3-033-05-0618	P&B PRD11AY0 220 Volt
	<u>ANTI-SWEAT HEATERS (115 Volt) ICE CREAM MODELS ONLY</u>		
17	Honeycomb Heater (First Guard Duct)	1-216-00-0016 1-216-00-0024	83 Watt .72 Amps. (8ft.) 125 Watt 1.09 Amps. (12ft.)
	<u>VALVES F.F.</u>		
20	Expansion Valve (502)	3-009-01-1051 3-009-01-1804	Sporlan GRE-1-RZP40 (8ft.) Sporlan GRE- 1-1/2 RZP40 (12ft.)
	<u>VALVES I.C.</u>		
20	Expansion Valve (502)	3-009-01-1804 3-009-01-2703	Sporlan GRE-1-1/2 RZP40 (8ft.) Sporlan GRE-2 RZP40 (12ft.)

*46 Display liner top overlay heaters installed in L5, L5A, L5F, & L5FA models but not connected. Can be field connected if conditions require it to eliminate ceiling frost.

**34 Hot Gas Defrost Models do not use the thermo-disc defrost termination, but a PENN. A19AAA-5 control.

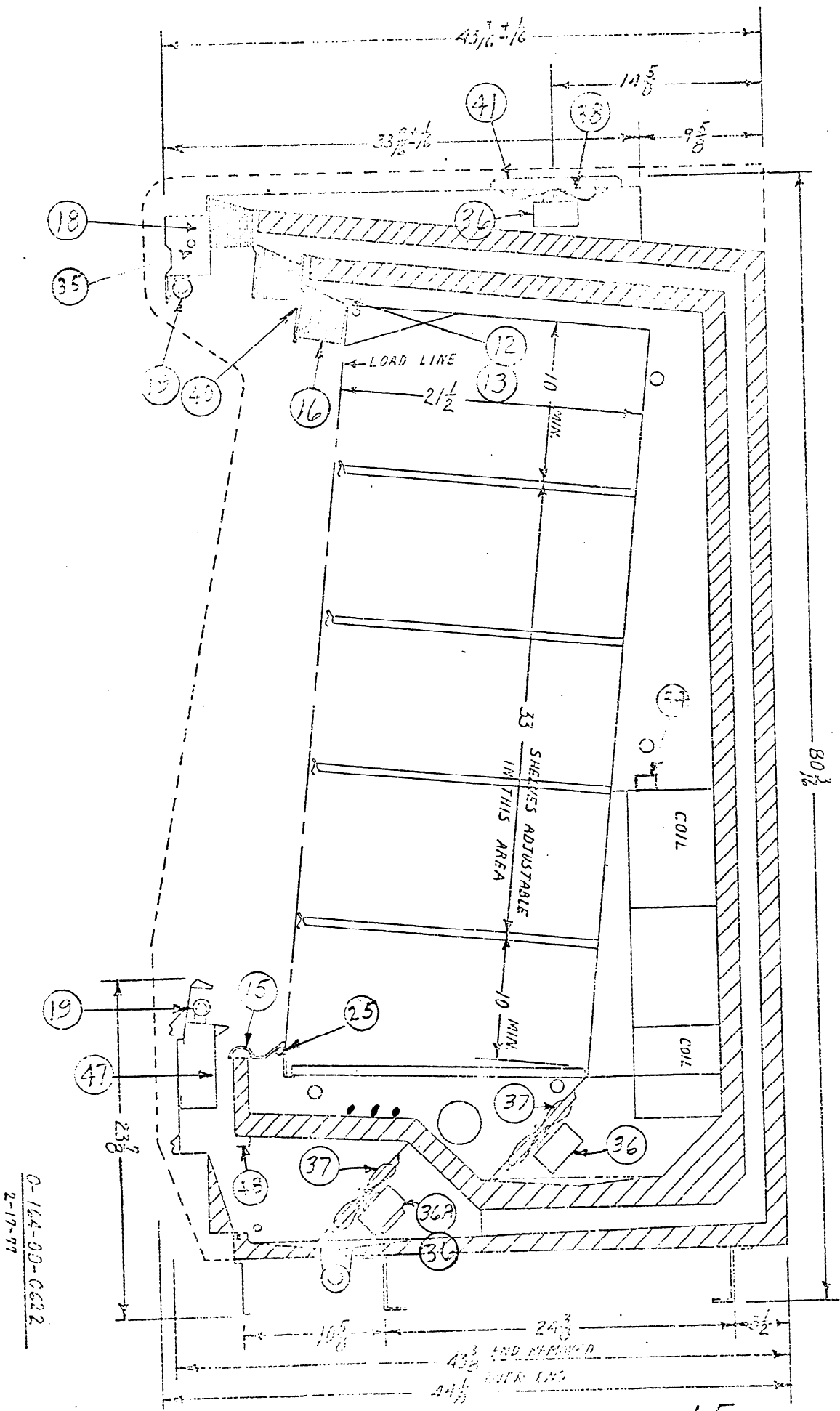

0-164-00-C622
 2-17-77

MODEL L5A
 REFRIG. AIR DEFROST
 L5
 ELECTRIC DEFROST

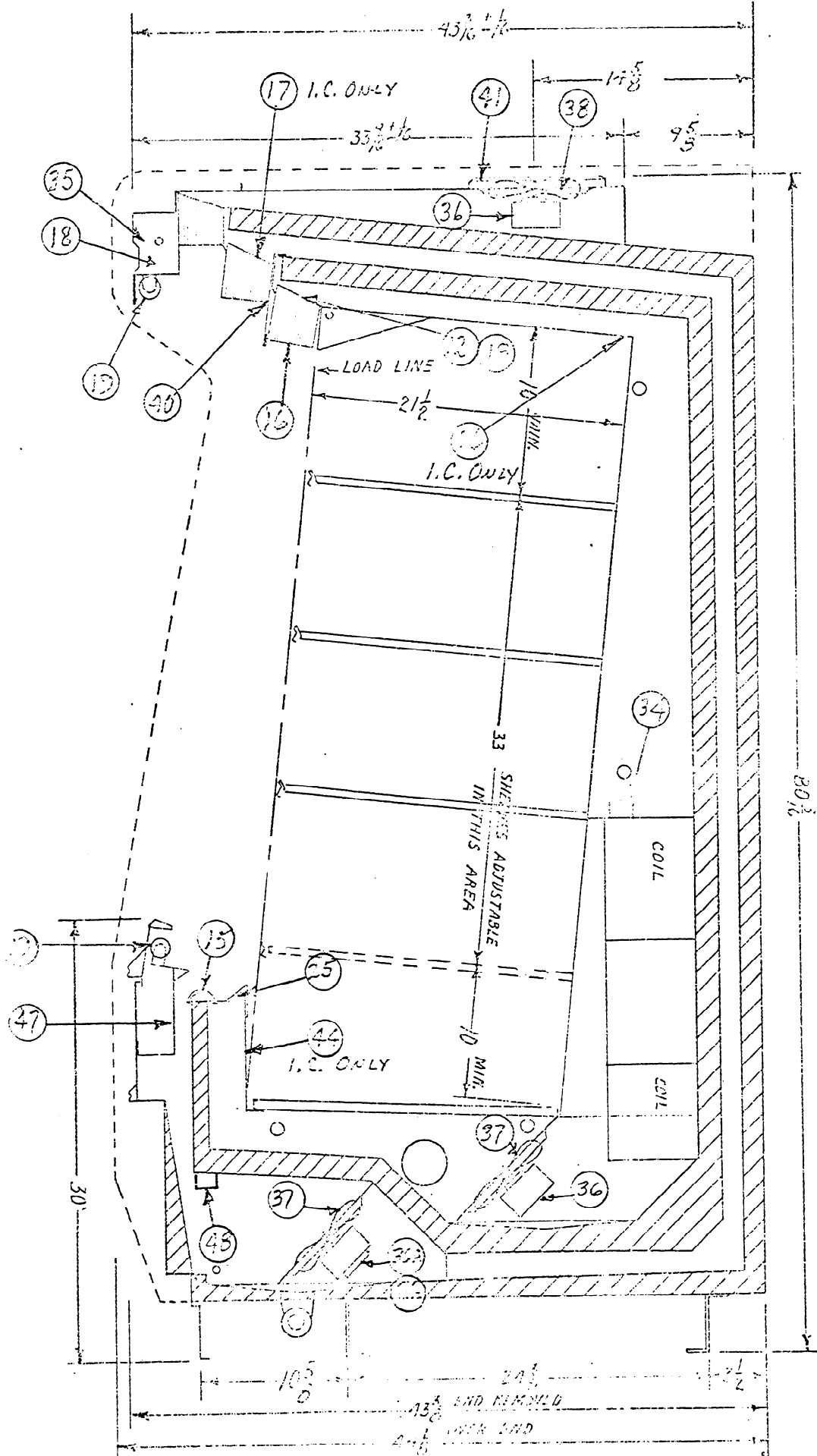

0-164-00-0630
2-16-77

MODEL LSPA 311A LSF & ISF
ELECTRIC

NOTE:
3" VENTILATION HOLES
IN RECESSED BASE

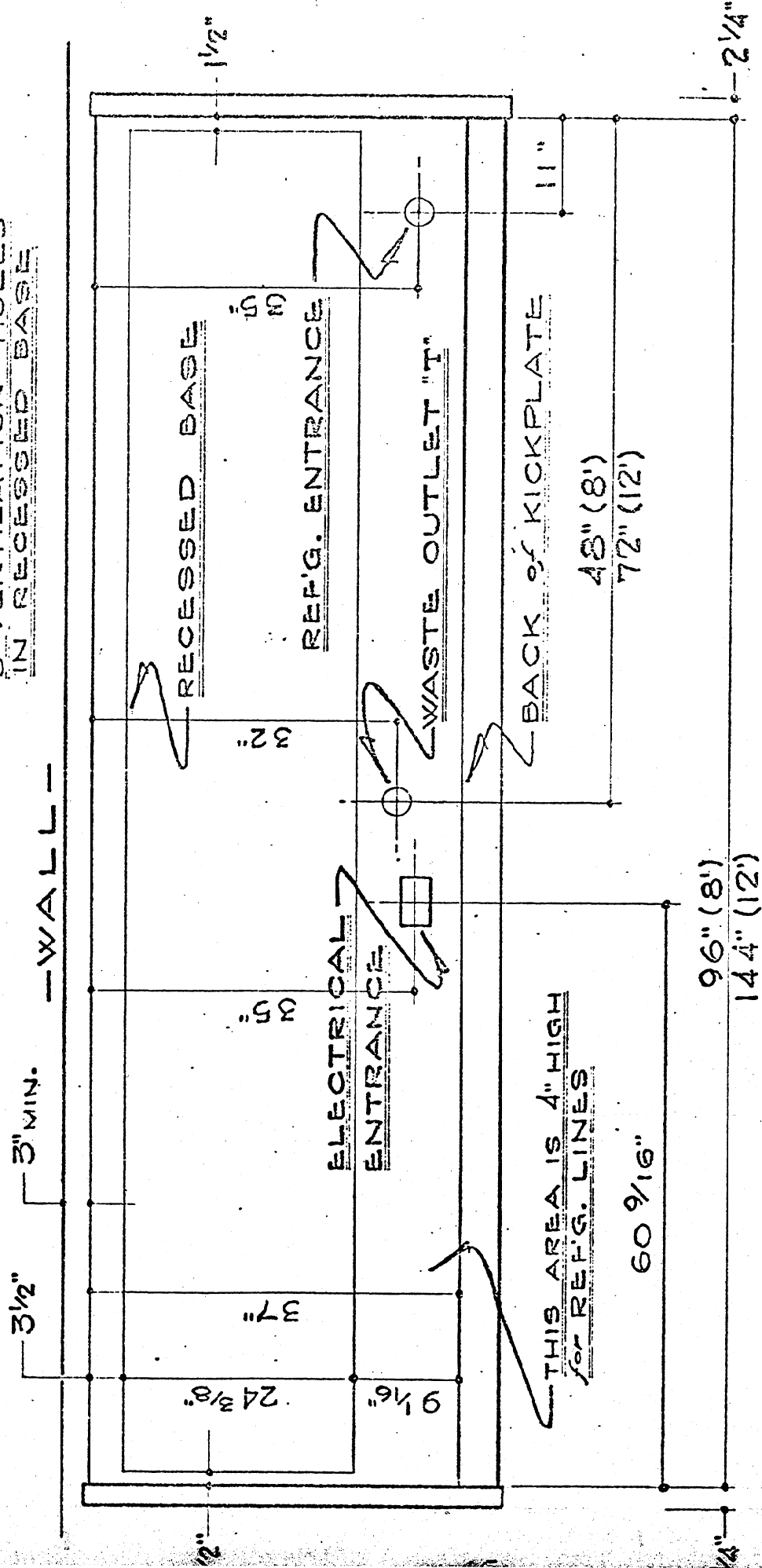

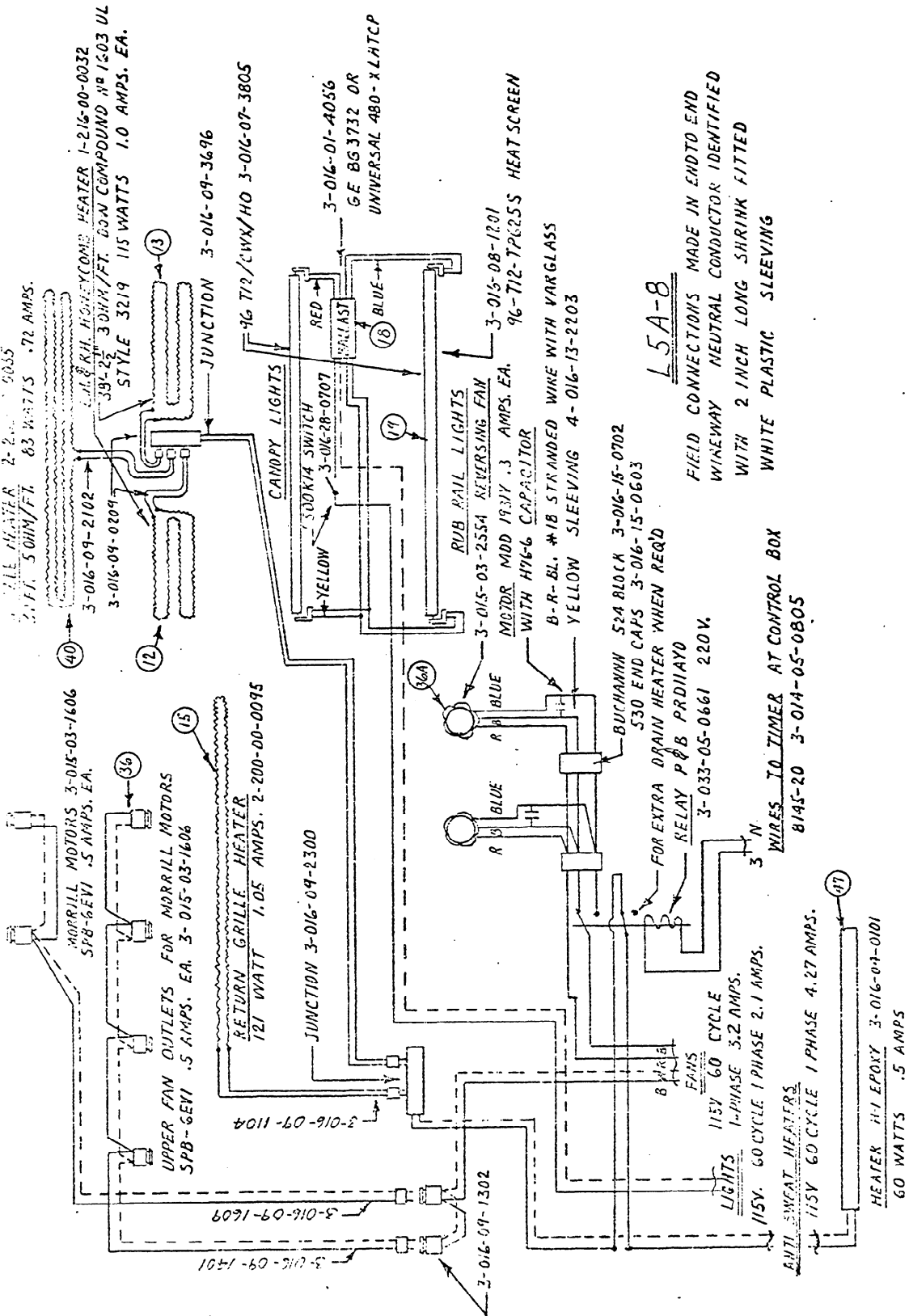

L5A-8

FIELD CONNECTIONS MADE IN ENDTO END
 WINEWAY NEUTRAL CONDUCTOR IDENTIFIED
 WITH 2 INCH LONG SHRINK FITTED
 WHITE PLASTIC SLEEVING

Wires to timer at control box
 B145-20 3-014-05-0805

L5A-8 CASE

WIRING DIAGRAM

FINISH	MED MATIC	FOAM	COOLER	CABINET	ELECT.	REFRIG.	CEL. REFRIG.	TRIM	CEL. TRIM	MILL	STOCK ROOM	SHIPPING
									<input checked="" type="checkbox"/>			
REV.	77028	77030								DRAWING NO.		ORDER NO.
	77028									0-368-00-0100		
										DATE		
										3-11-79		

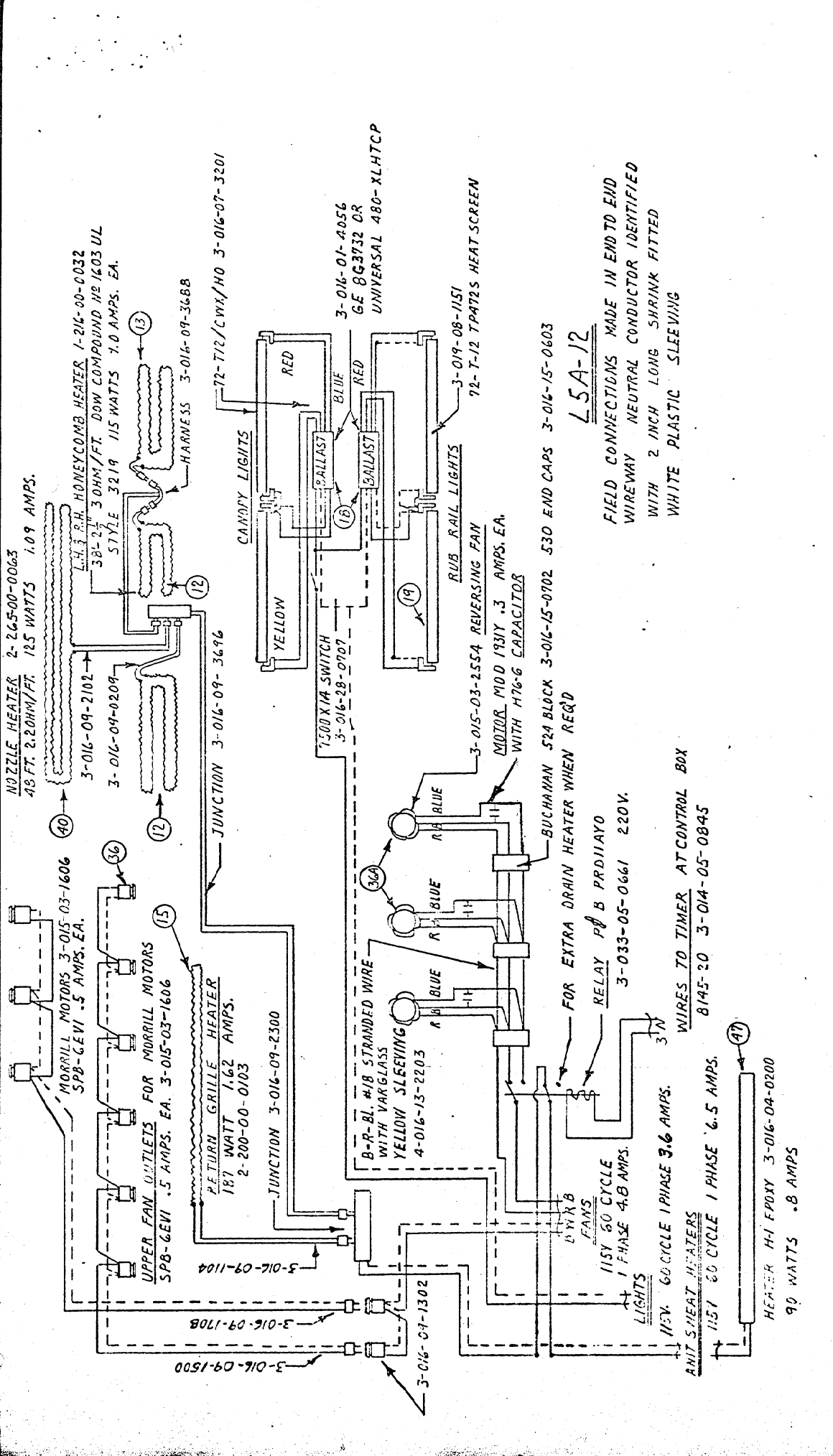

WIREMATIC	FOAM	COOLER	CABINET	ELECT. X	REFRIG.	REFRIG.	CELL. REFRIG.	TRIM	X	CEL. TRIM	MILL	STOCK ROOM	SHIPPING ORDER NO.
REVS.	77030									DRAWING NO.	DSG-BY	DEPT.	
	77022									0-368-00-0618	DRN-BY		
	77028									DATE 3-14-77			
WIRING DIAGRAM													

LSA-12 CASE

LSA-12

FIELD CONNECTIONS MADE IN END TO END
WIREWAY NEUTRAL CONDUCTOR IDENTIFIED
WITH 2 INCH LONG SHRINK FITTED
WHITE PLASTIC SLEEVING

WIRES TO TIMER AT CONTROL BOX
8145-20 3-014-05-0845

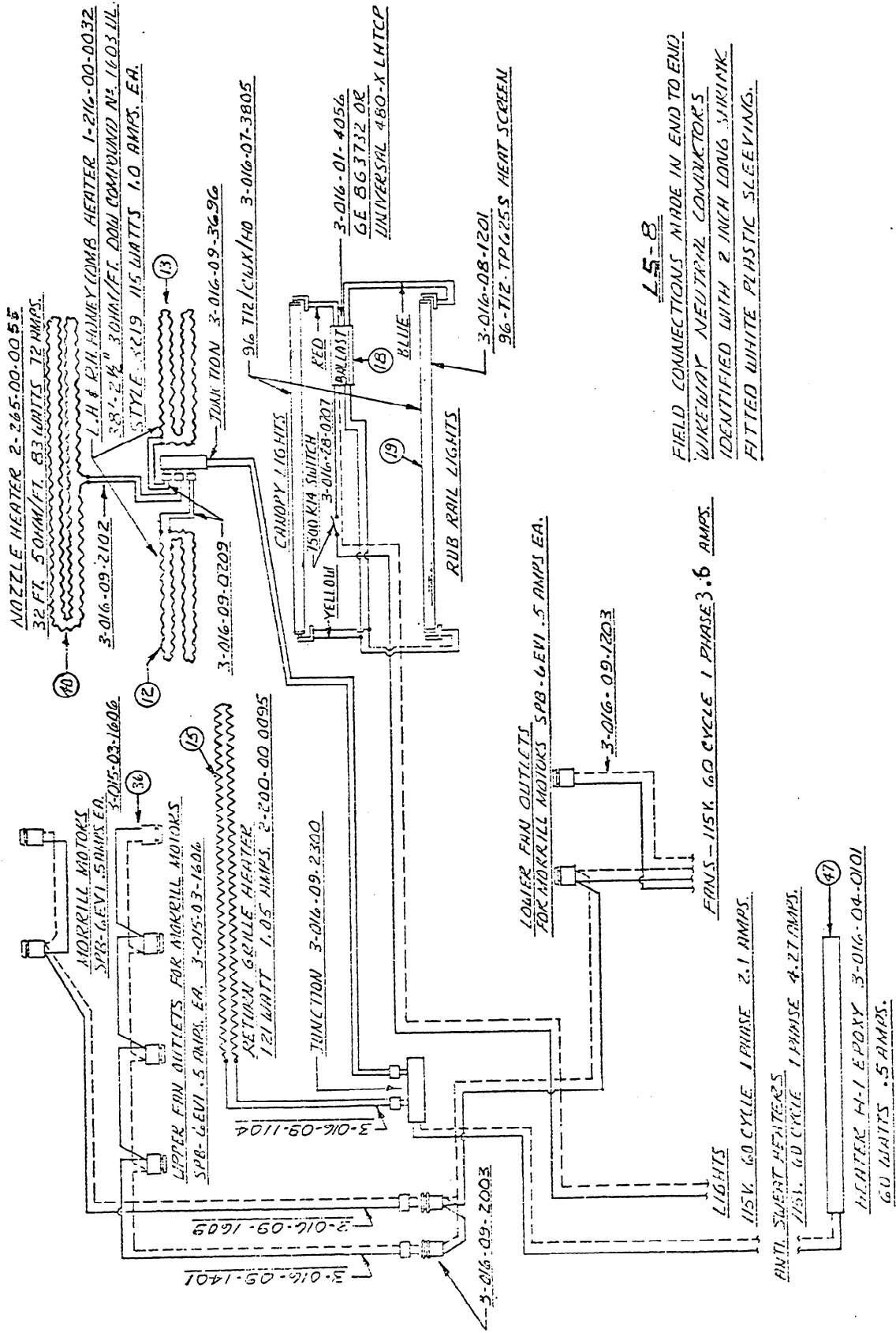

15-8

FIELD CONNECTIONS MADE IN END TO END
WIREWAY NEUTRAL CONNECTORS
IDENTIFIED WITH 2 INCH LONG MARK
FITTED WHITE PLASTIC SLEEVINGS.

REV'S	FINISH	HYDRA-MATIC	FOAM	COOLER	CABINET	REFRIG.	REFRIG.	CEL. REFRIG.	TRIM	CEL. TRIM	MILL	STOCK ROOM	SHIPP. ORDER	
PART NAME												DES-BY	DRN-BY	DEPT.
WIRING DIAGRAM												0-328-00-0642	DRNBY C.L.E.	
												DATE	2.27.77	

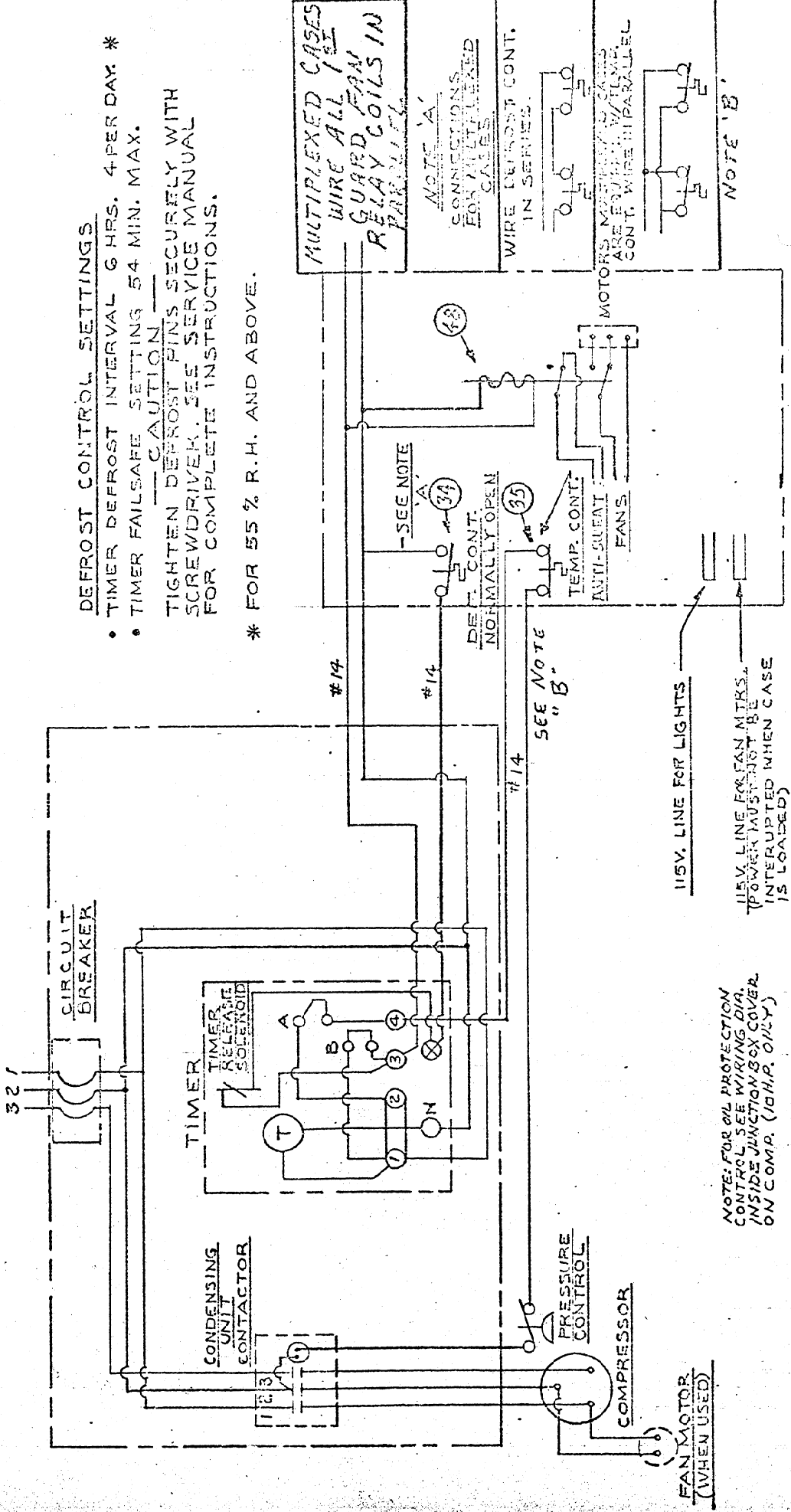

DEFROST CONTROL SETTINGS

- TIMER DEFROST INTERVAL 6 HRS. 4 PER DAY *
- TIMER FAILSAFE SETTING 54 MIN. MAX.

CAUTION

TIGHTEN DEFROST PINS SECURELY WITH SCREWDRIVER. SEE SERVICE MANUAL FOR COMPLETE INSTRUCTIONS.

* FOR 55% R.H. AND ABOVE.

MULTIPLXED CASES
WIRE ALL 1ST
GUARD FAN
RELAY COILS IN
PARALLEL

NOTE 'A'
CONNECTIONS
FOR MULTIPLE
CASES

WIRE DEFROST CONT.
IN SERIES.

MOTORS MUST BE
EQUIPPED WITH
TEMP. CONTROL. WIRE IN PARALLEL

NOTE: FOR OIL PROTECTION
CONTROL SEE WIRING DIA.
INSIDE JUNCTION BOX COVER
ON COMP. (1011.P. ONLY)

WIRING DIAGRAM

75A

ALL ANTI-SWEAT HEATERS ARE CONNECTED TO ONE POLE OF THE DEFROST RELAY 48.
THE 1st. GUARD MOTORS ARE CONNECTED TO THE 2nd. POLE. WHEN THE RELAY COIL
IS ENERGIZED THE 1st. GUARD FAN MOTORS ARE REVERSED AND THE ANTI-SWEAT HEAT IS CUT OFF.

DEFROST CONTROL SETTINGS

- o TIMER DEFROST INTERVAL 6 HRS - 1/2 PER DAY
- o TIMER FAULTSAFE SETTING 30 MIN. MAX.
- o CAUTION - TIGHTEN DEFROST PINS SECURELY W/ SCREWDRIVER. SEE SERVICE MANUAL FOR COMPLETE INSTRUCTIONS.

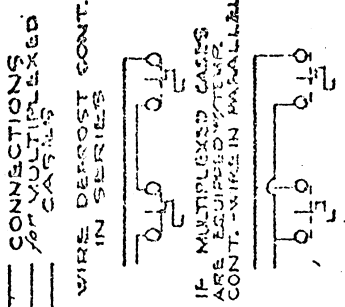
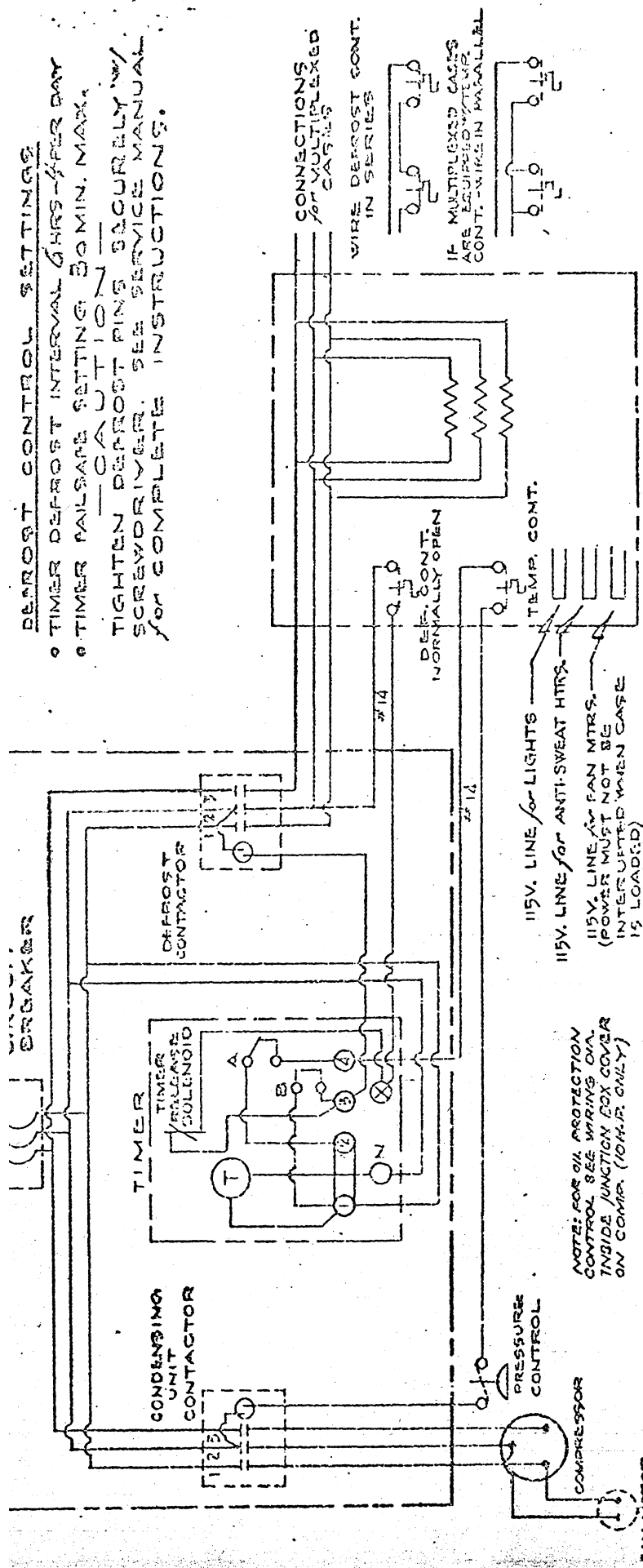

WIRING DIAGRAM

15-881512

WHEN VOLTAGE IS 1.00 for 208V.
OTHER THAN 208V. 1.06 for 220V.
MULTIPLY AMPS BY 1.11 for 230V.
FACTOR INDICATED 1.15 for 240V.

LENGTH of CASES	WATTS @ 230V.	DEFROST CIRCUIT			60 CYCLE CONTACTOR	WIRE # 4 SIZE
		208V. AMPS LINE 1	AMPS LINE 2	AMPS LINE 3		
8	6000	13.6	13.6	13.6	NONE REQD	12
12	9000	20.4	20.4	20.4	" "	10
15	12000	27.2	27.2	27.2	" "	10
20	15000	34.0	34.0	34.0	" "	10
24 (2-12)	15000	40.8	40.8	40.8	" "	6
24 (3-8)	15000	40.8	40.8	40.8	" "	6
28 (7-3)	21000	47.6	47.6	47.6	" "	6
32 (1-3)	24000	51.4	51.4	51.4	75A-3P	4
36 (3-12)	27000	61.2	61.2	61.2	90A-3P	4

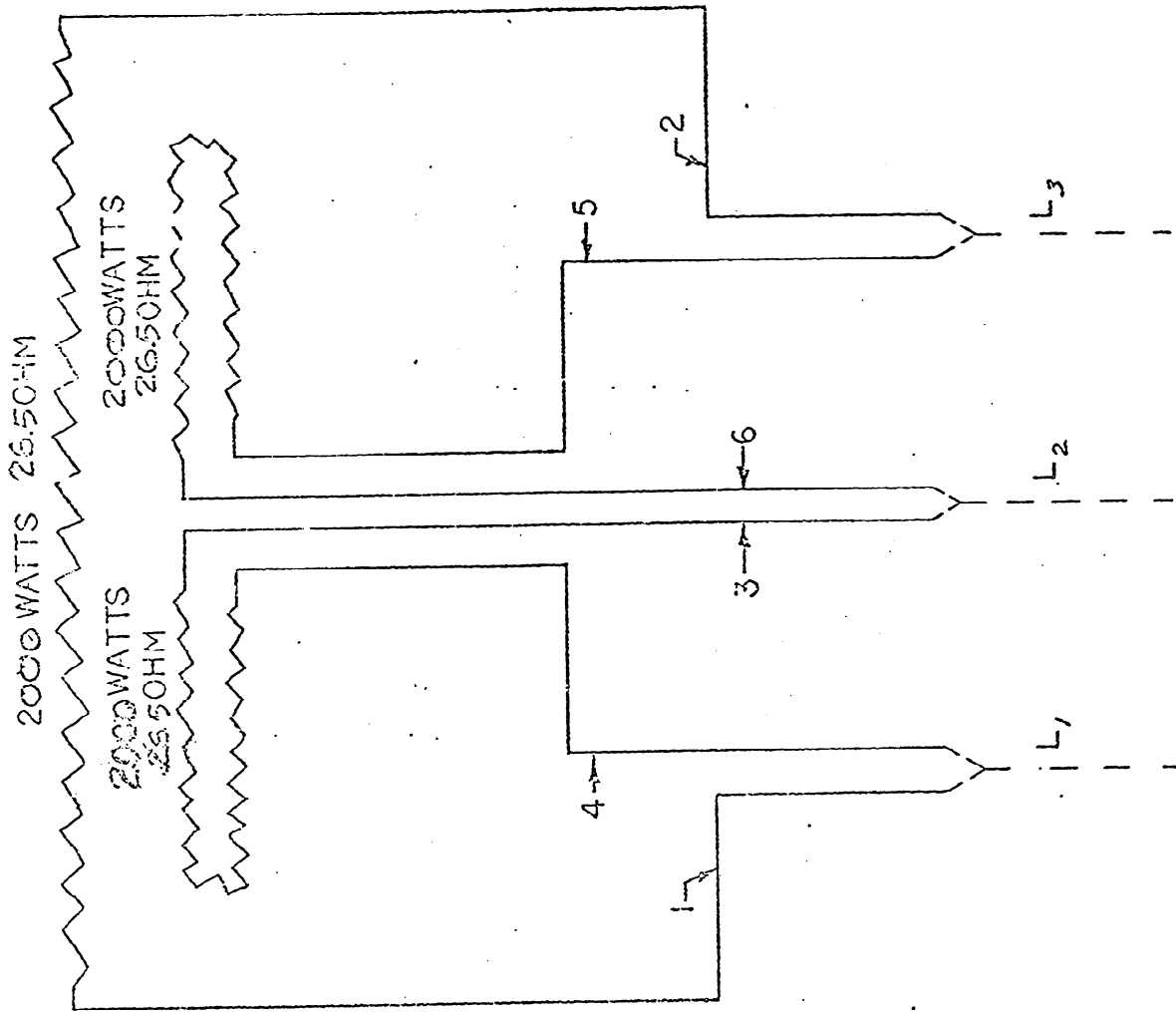

3 PHASE
DEFROST HEATER CIRCUIT

LINE	208 VOLT	220 VOLT
L ₁	13.6 AMP	14.4 AMP
L ₂	13.6 AMP	14.4 AMP
L ₃	13.6 AMP	14.4 AMP

L5-B

DOTTED LINES INDICATES
FIELD WIRING

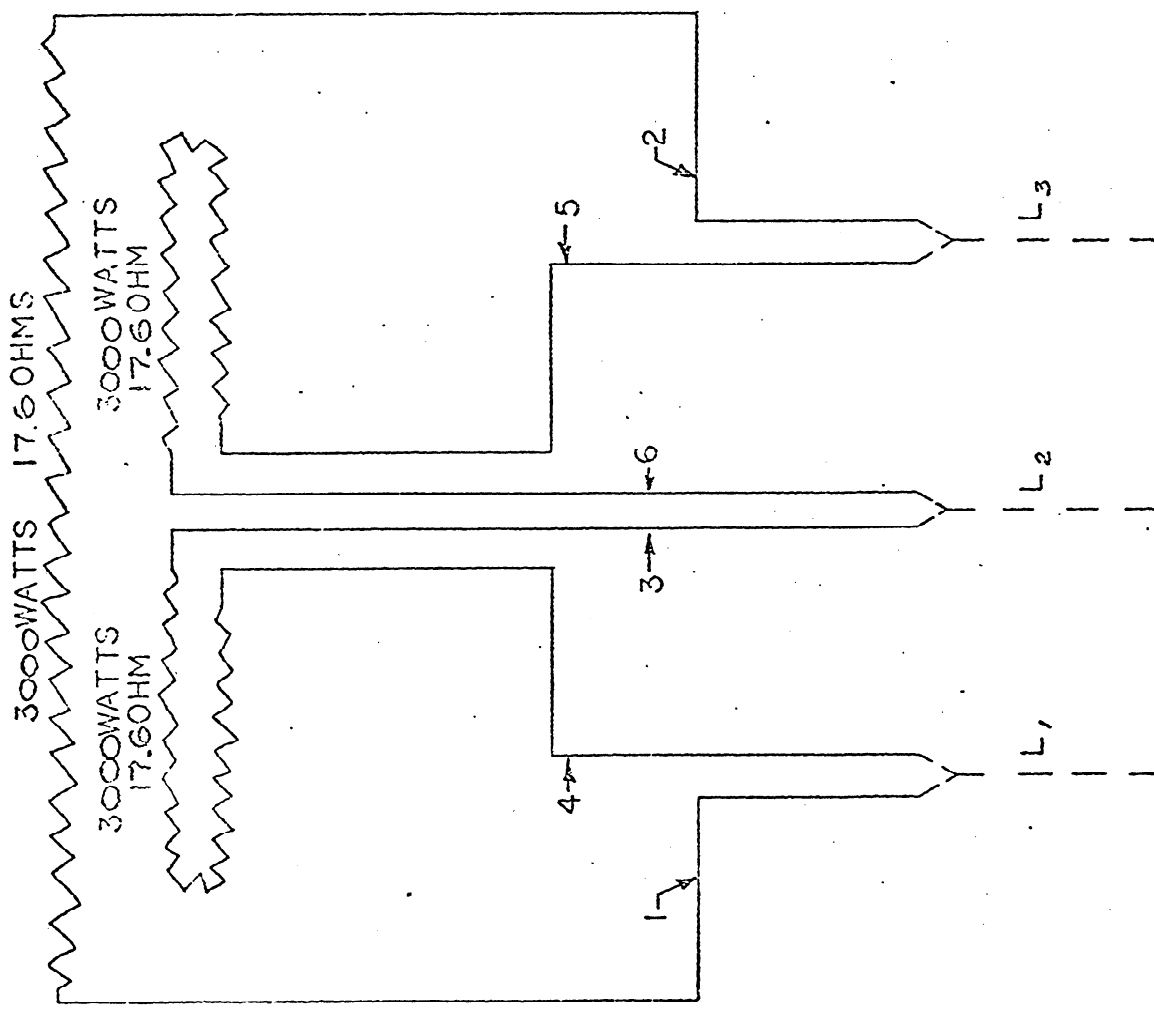

3 PHASE
DEFROST HEATER CIRCUIT

LINE	208 VOLT	220 VOLT
L ₁	20.4 AMP	21.6 AMP
L ₂	20.4 AMP	21.6 AMP
L ₃	20.4 AMP	21.6 AMP

L 5 - 12

DOTTED LINES INDICATE
FIELD WIRING

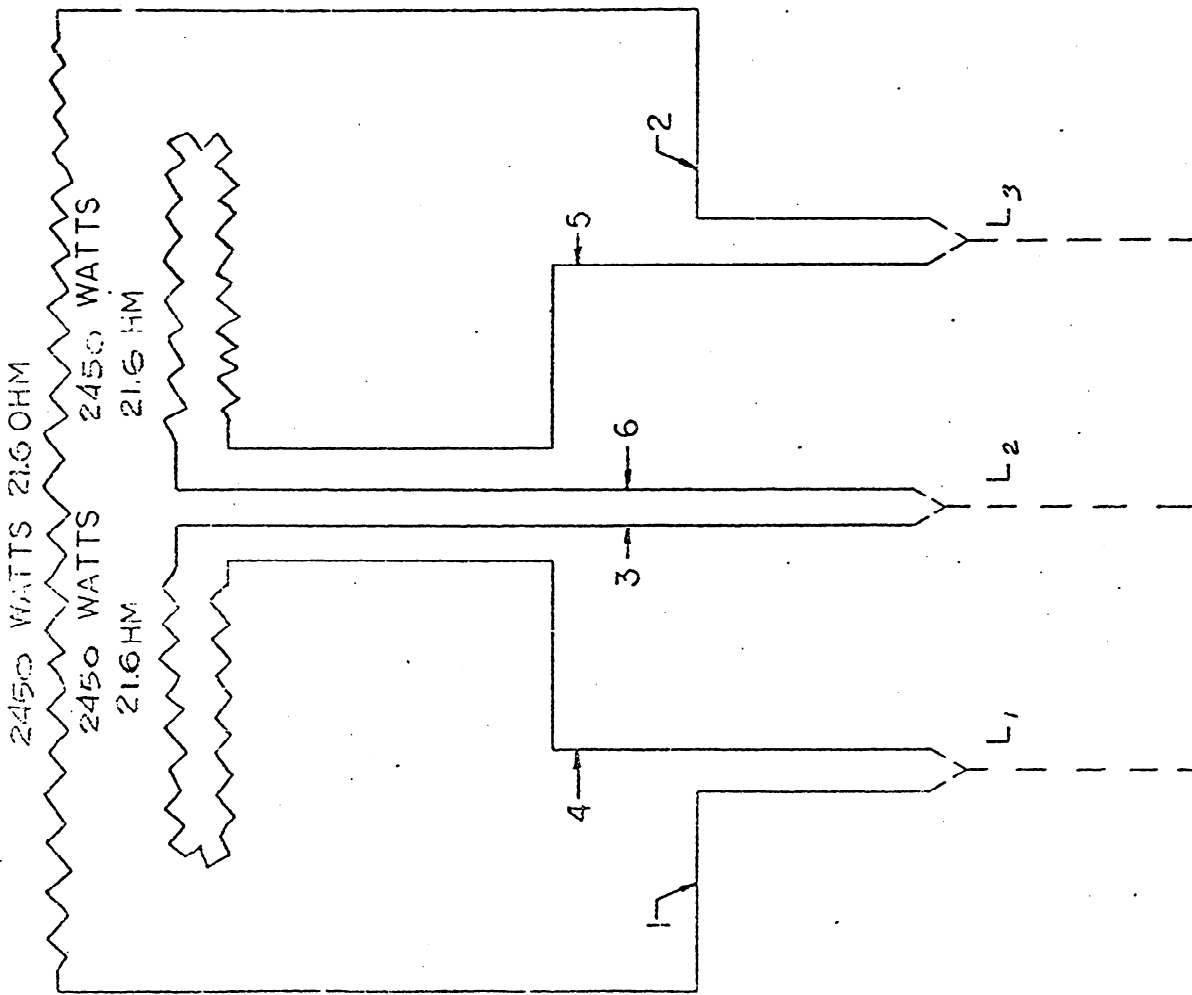

DOTTED LINES INDICATES
FIELD WIRING

3 PHASE
DEFROST HEATER CIRCUIT

LINE	208 VOLT	220 VOLT
L ₁	16.6 AMP	17.7 AMP
L ₂	16.6 AMP	17.7 AMP
L ₃	16.6 AMP	17.7 AMP

I 5 / - 8

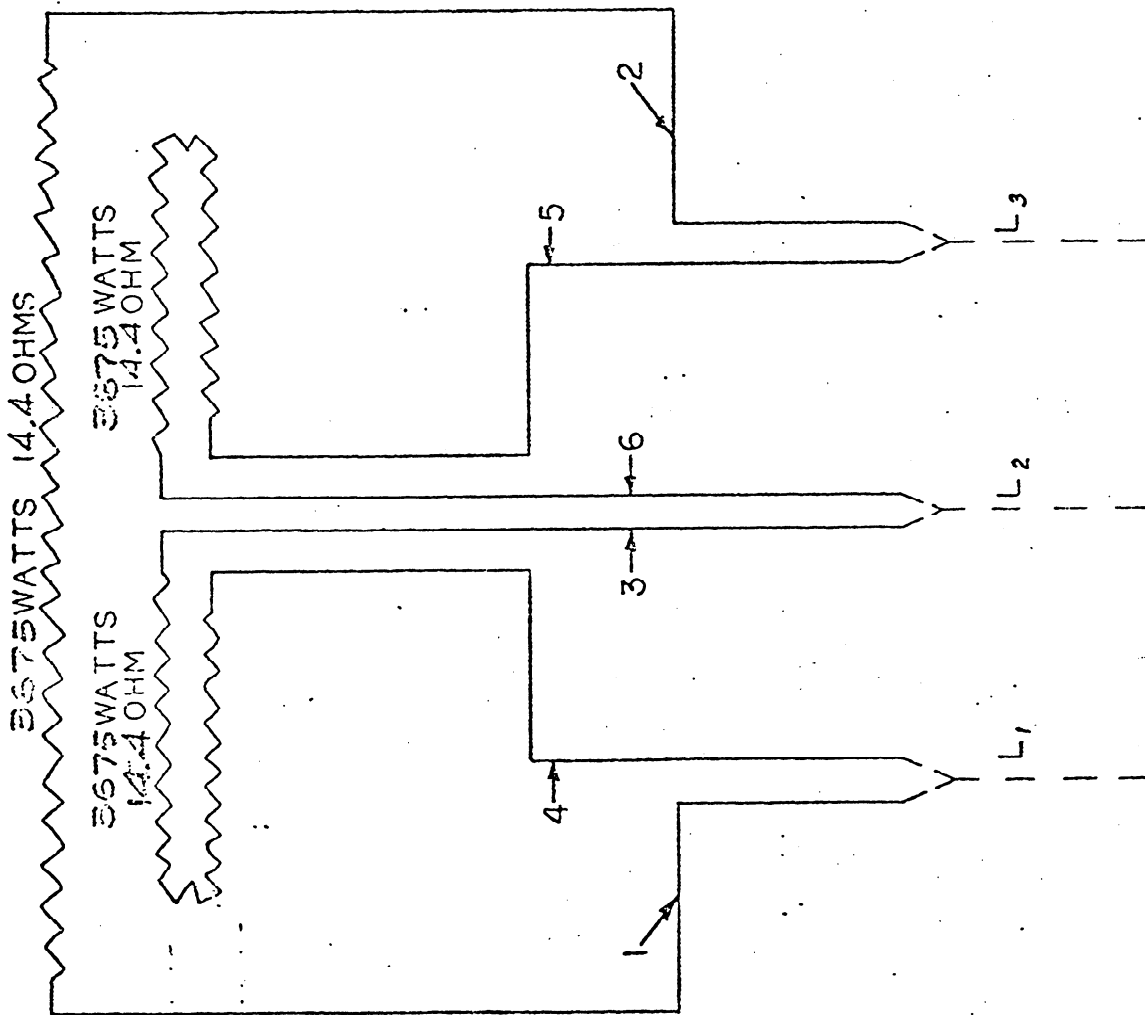

3 PHASE

DEFROST HEATER CIRCUIT

LINE	208 VOLT	220 VOLT
L ₁	24.9 AMP	26.3 AMP
L ₂	24.9 AMP	26.3 AMP
L ₃	24.9 AMP	26.3 AMP

I 5 F - 12

DOTTED LINES INDICATE
FIELD WIRING

REPAIR NUMBER	QUANTITY	DESCRIPTION
A	1	TRIM-COLOR BAND UPPER CONNECTOR
B	1	TRIM-COLOR BAND LOWER CONNECTOR
C	1	CASTING-JOINT TRIM (W/10-57)
D	1	TRIM-LOWER FRONT TOP CONNECTOR
E	1	TRIM-LOWER FRONT BOTTOM CONNECTOR
F	1	BOLT 3/8 - 16 X 5" HEX. HD. STL.
G	4	BOLT 3/8 - 16 X 3" HEX. HD. STL.
H	2	BOLT 3/8 - 16 X 1" HEX. HD. STL.
I	12	FLAT WASHER PLT'D. 1/8 X 13/32 X 1 3/8
J	2	FLAT WASHER PLT'D. 3/8
K	2	NUT 3/8 - 16 HEX
L	7	SCREW #6-A X 3/4 TRUSS HEAD
M	2	SCREW # 10-24 X 1/2 TRUSS HEAD
N	2	SCREW # 8-A X 1/2 OVAL HD. N.P.
O	2	SCREW # 10-A X 1/2 TRUSS HEAD
P	2	SCREW # 10-A X 1/2 TRUSS HEAD
Q	3	CAULKING COMPOUND

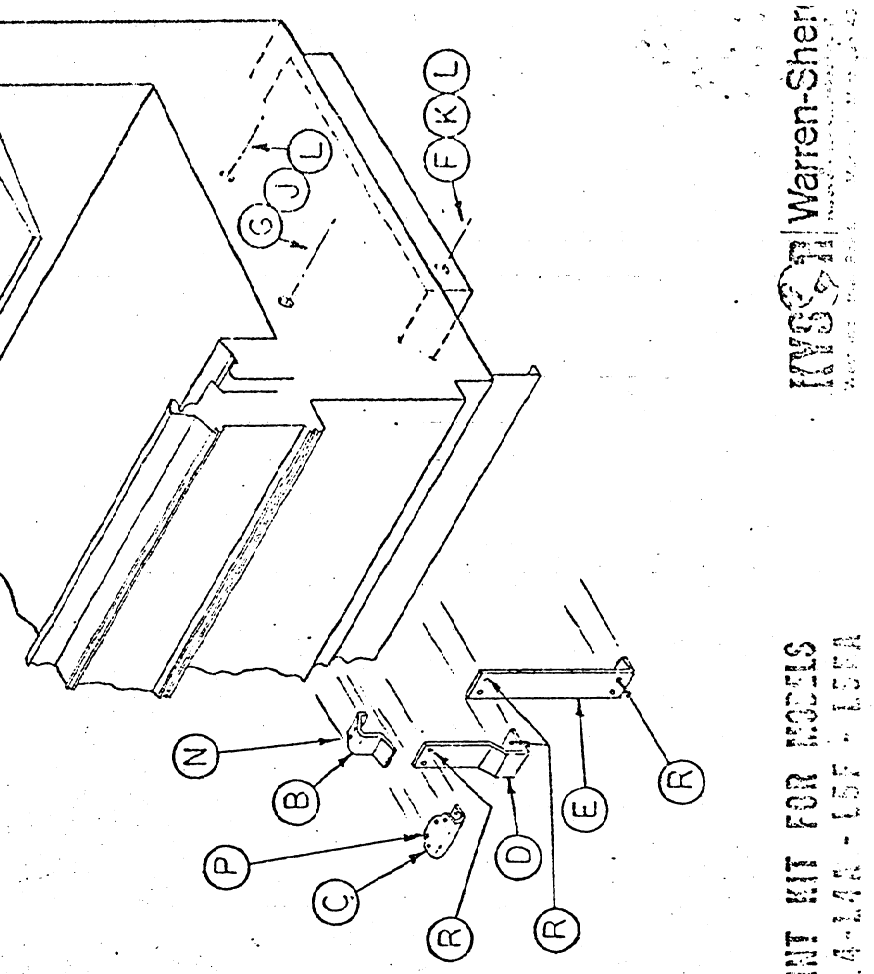

- Remove case from crate skids and set in final location, remove shipping supports. Note: Avoid dropping nuts and washers into case as they will plug drain.
- Check floor for level, how much shimming is required and how service outlets are located. Decide which case to be installed first, move others out of the way.
- Position remaining cases and level, using metal shims furnished. Level per enclosed instructions. Caulk end of joining case, move into position and adjust to obtain good alignment.
- Remove (2) round plastic plug buttons at each end of display back panel.
- Install 3/8-16 x 5" long hex. bolt, washers and nut in alignment-pull up lugs at the front of base and tighten. Use pry bar to assist tightening of bolt and getting cases tight and in straight line.
- Install 3/8-16 x 3" long hex bolts, washers and nuts in the holes accessible from display area, front, lower back, center and upper back. Install 3/8-16 x 1" long hex bolts, washers and nuts in upper front and canopy joining holes.
- Check alignment and adjust if necessary. Tighten all joining bolt firmly.
- Install color band trim (sym.B) first, using # 10-24 x 1/2 long truss head bolts in threaded fasteners provided in case. Adjust trim for best fit and tighten screws.
- Install casting (sym.C) over joint as shown and fasten using #8A x 1/2" long oval head N.P. screws.
- Install lower trim top and bottom (sym.D & E) over joints as shown and fasten using #10A x 1/2 truss head screws.
- Install canopy trim (sym.A) which is shaped to fit the canopy and the recessed area in canopy. Locate over the joint and fasten with # 6A x 3/4 long truss head screws.

MODEL	SYM. REQ'D	PART NUMBER	DESCRIPTION
L5 & L5A	A	2-165-00-0163	DIVIDER-TOP RETAINER OUTSIDE
L5 & L5A	B	2-165-00-0320	DIVIDER- PLEXIGLAS
L5 & L5A	C	2-165-00-0338	DIVIDER-BOTTOM RETAINER OUTSIDE
L5 & L5A	D	3-028-09-0854	SCREW # 10-A x 1/2 TRUSS HEAD
L5F & L5FA	A	2-165-00-0163	DIVIDER-TOP RETAINER OUTSIDE
L5F & L5FA	B	2-165-00-0353	DIVIDER- PLEXIGLAS
L5F & L5FA	C	2-165-00-0361	DIVIDER-BOTTOM RETAINER OUTSIDE
L5F & L5FA	D	3-028-09-0854	SCREW # 10 A x 1/2 TRUSS HEAD

1. Locate bottom divider. (sym.C) In position as shown and fasten in place using 2 screws (sym.D)
2. Place top divider (sym.A) in position between cases then slide plexiglass (sym.B) in grooves provided in metal dividers. Then tighten cases together.
3. Other parts shown are part of joint kit. See joint kit section in manual for part numbers.

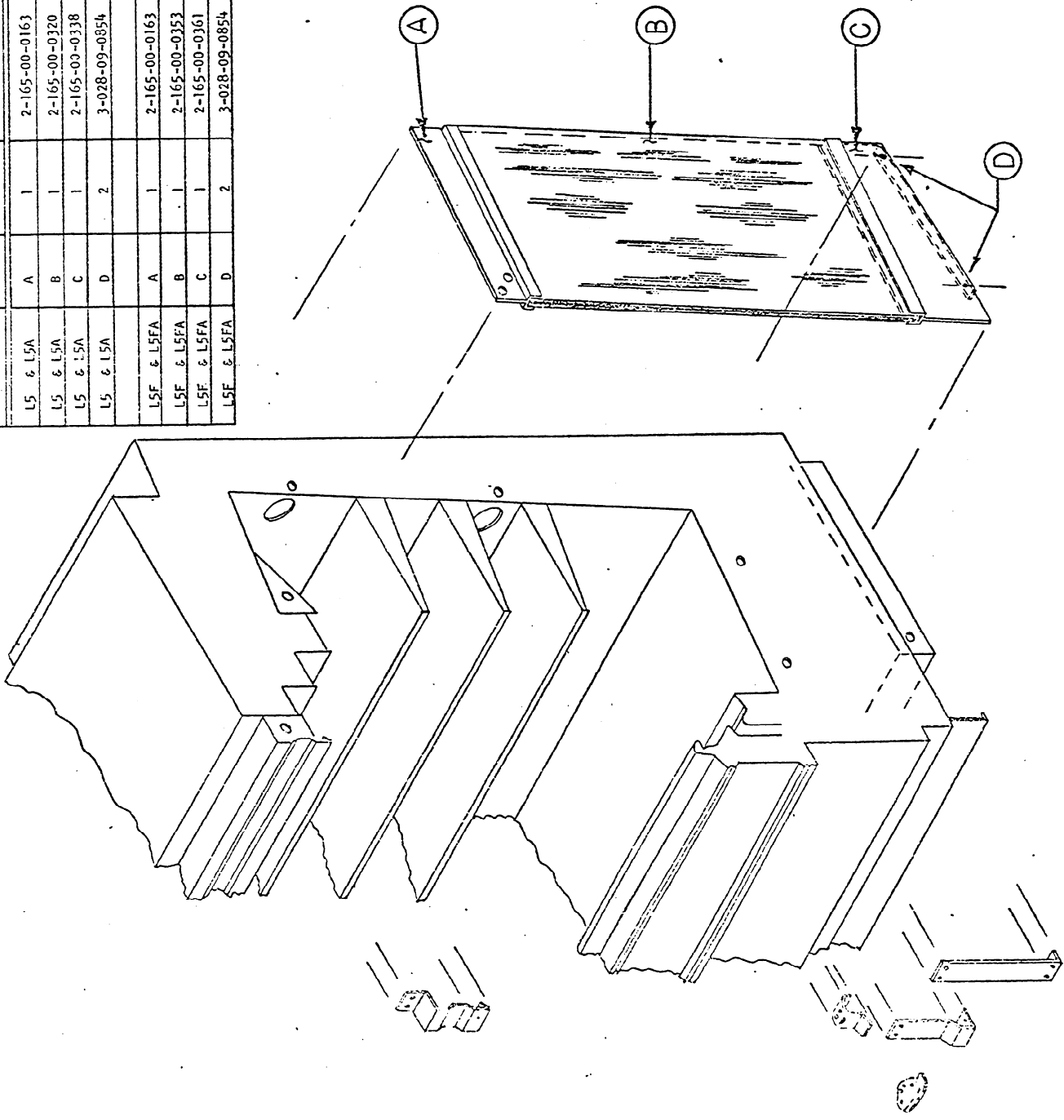

PLEXIGLAS DIVIDER KIT
 FOR MODELS L5-L5A-L5F & L5FA

SYM.	REQ'D.	PART NUMBER	DESCRIPTION
A	1	2-355-00-0617	TRIM-CONNECTOR CANOPY
B	1	3-355-00-1179	TRIM-COLOR BAND UPPER CONNECTOR
C	1	3-039-06-1317	CASTING-JOINT TRIM (#16F10-57)
D	1	2-355-00-1151	TRIM-LOWER FRONT TOP CONNECTOR
E	1	2-355-00-1157	TRIM-LOWER FRONT BOTTOM CONNECTOR
F	1	3-027-03-1305	BOLT 3/8-16 X 5" HEX. HD. STL.
G	4	3-027-03-0201	BOLT 3/8-16 X 3" HEX. HD. STL.
H	2	3-027-03-0109	BOLT 3/8-16 X 1" HEX. HD. STL.
J	12	3-026-04-0802	FLAT WASHER PLT'D. 1/8 X 13/32 X 1 3/8
K	2	3-026-04-0406	FLAT WASHER PLT'D. 3/8
L	7	3-026-01-0507	NUT 3/8-16 HEX.
M	2	3-028-09-0409	SCREW # 6-A X 3/4 TRUSS HEAD
N	2	3-028-05-0106	SCREW # 10-24 X 1/2 TRUSS HEAD
P	8	3-028-07-0310	SCREW # 8-A X 1/2 OVAL HD. N.P.
R	8	3-026-05-0653	SCREW # 10-A X 1/2 TRUSS HEAD
S	3 Tubes	4-017-05-0107	CAULKING COMPOUND

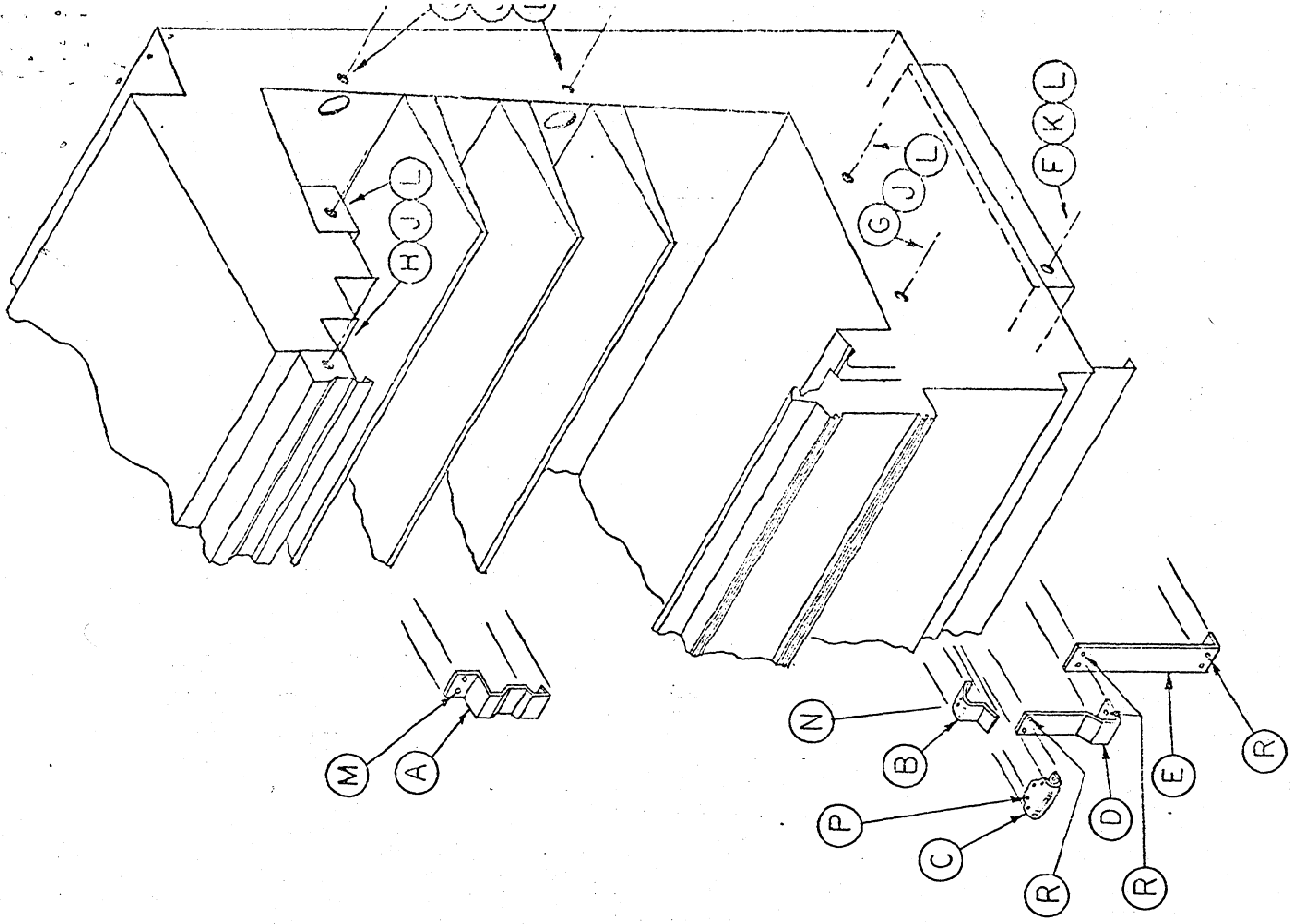

1. Remove case from crate skids and set in final location, remove shipping supports.
Note: Avoid dropping nuts and washers into case as they will plug drain.
2. Check floor for level, how much shimming is required and how service outlets are located. Decide which case to be installed first, move others out of the way.
3. Position remaining cases and level, using metal shims furnished. Level per enclosed instructions. Caulk end of joining case, move into position and adjust to obtain good alignment.
4. Remove (2) round plastic plug buttons at each end of display back panel.
5. Install 3/8-16 X 5" long hex bolt, washers and nut in alignment-pull up lugs at the front of base and tighten. Use pry bar to assist tightening of bolt and getting cases tight and in straight line.
6. Install 3/8-16 X 3" long hex bolts, washers and nuts in the holes accessible from display area, front, lower back, center and upper back. Install 3/8-16 X 1" long hex bolts, washers and nuts in upper front and canopy joining holes.
7. Check alignment and adjust if necessary. Tighten all joining bolt firmly.
8. Install color band trim (sym.B) first, using #10-24 X 1/2 long truss head bolts in threaded fasteners provided in case. Adjust trim for best fit and tighten screws.
9. Install casting (sym.C) over joint as shown and fasten using #8A X 1/2" long oval head N.P. screws.
10. Install lower trim top and bottom (sym.D & E) over joints as shown and fasten using # 10A X 1/2 Truss head screws.
11. Install canopy trim (sym.A) which is shaped to fit the canopy and the recessed area in canopy. Locate over the joint and fasten with #6A X 3/4 long truss head screws.

SYM	REQD	PART NUMBER	DESCRIPTION
A	1	2-150-00-0667	CLOSURE-TOP SINCE END
B	1	2-130-00-2500	BRACKET-END KICK RAIL CLOSURE
C	2	3-078-06-0105	SCREWS BINDERHEAD 1/2 X 10-24 S.S.
D	2	3-028-06-0303	SCREWS BINDERHEAD 3/4 X 10 S.S.

Case in final position with refrigeration, electrical, drain lines and front toe space cover installed, proceed as follow.

1. Depending whether case is standard or has aisle warmer kit. Position bracket (sym.B) and drill 2-5/32 dia. holes for # 1/2 x 10-24 screws (sym.C) and fasten.
2. Drill 2-7/32 dia. holes in front toe space cover 1/2" in from end.
3. Position closure toe space end (sym.A) and drill 4 1/8 dia. holes for # 3/4 X 10 SS screws (sym.D) and fasten.

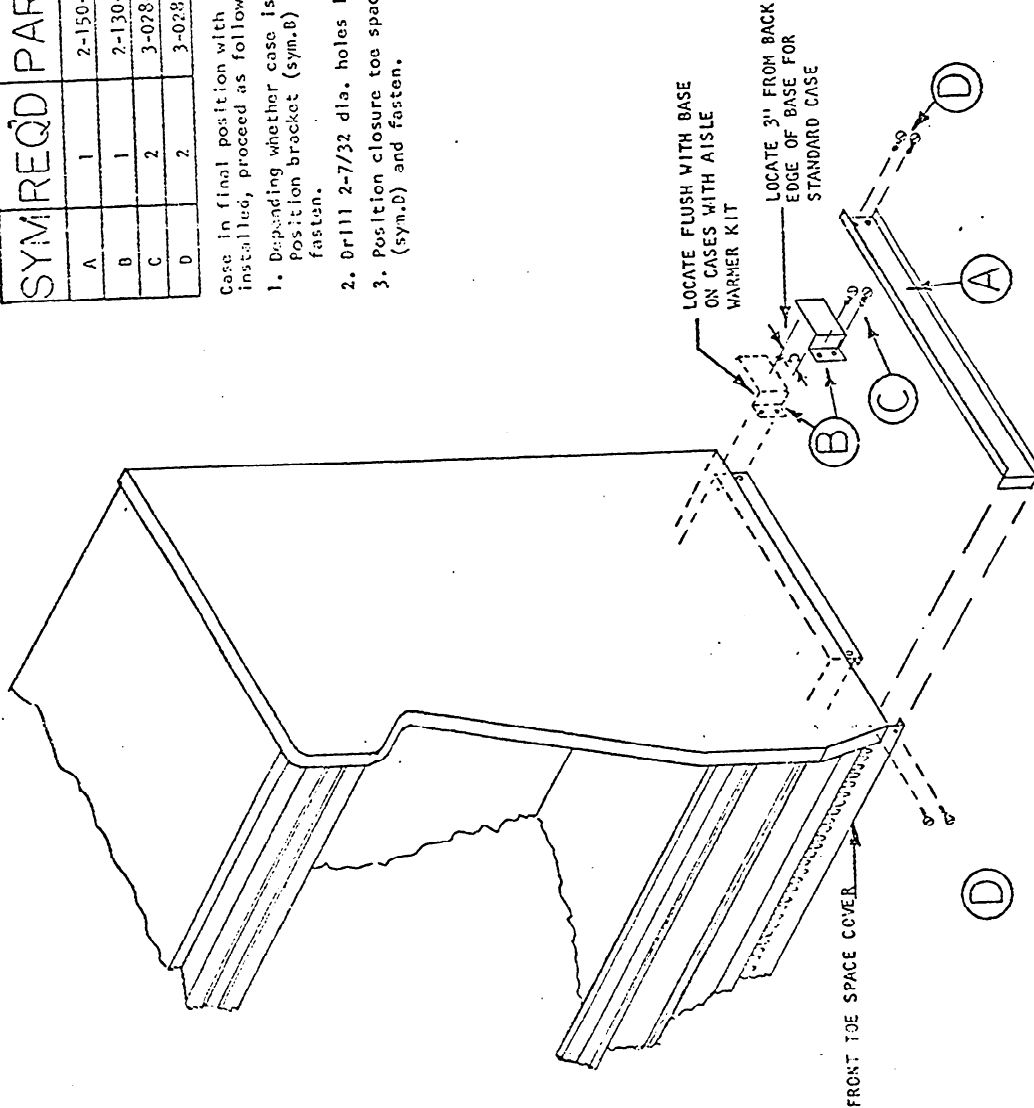

END TOE SPACE COVER
FOR MODELS L4A, L5A OR L5FA

IMPORTANT

HEALTH AND SANITATION STANDARD FOR RETAIL FOOD STORE REFRIGERATION

7400 and Mark VII frozen food and ice cream models were designed and built in compliance with CRMA Health and Sanitation Standard CRS-S1-67.

Since sanitation must necessarily be a joint effort of manufacturer, installer and user, recommendations and instructions for both installer and user are listed below. Beyond furnishing practical recommendations, the manufacturer cannot be responsible for unsanitary installation or usage.

INSTALLER'S RESPONSIBILITIES (See Section VII of Standard)

Display cases must be carefully leveled to insure that drains in case can function properly. Shims and other leveling means user must provide a firm support for the case to insure that case will remain level for its useful life.

Manufacturer furnishes a line type drain trap that must be connected to the drain fitting on each cabinet. The trap must be located within 3 ft. of the cabinet and discharge must not be directly connected to sewer line but rather discharge into drain sump. Caution: Do not reduce drain line size smaller than what is provided at case. Drain sump is cast aluminum.

Cases must be installed a minimum distance of 3 inches from wall so as to permit adequate ventilation. If cases are installed back to back, a forced ventilating system must be incorporated. A suitable kit can be purchased from manufacturer.

Installing ends and/or joining cases must be according to instructions furnished by manufacturer. Special care must be exercised to insure that joints are sealed properly, especially in lower areas of joint.

Toe space cover panel is adjustable and should be installed to make a sanitary joint with floor. If floor is irregular or an unusual amount of shimming was necessary to level cases so that range of adjustment on panel furnished is exceeded, installer must provide and install additional materials as required or advise owner of condition so he can arrange to have corrections made.

The open space between wall and end of case must be neatly closed with hardboard or other material acceptable to owner so as to prevent the accumulation of debris back of case.

Space between wall and top of case must be covered with a suitable screen or grille to guard from debris finding its way into this space.

Since proper temperatures are most important for sanitation, installer must make sure cases are performing properly before he permits owner to load cases with product. Temperature of air discharging from honeycomb must be zero degrees or lower except during defrost cycle.

OWNER RESPONSIBILITIES. (See Sections VIII and IX)

General: To insure minimum maintenance cost of operating your cabinet and to meet all local sanitary codes, this cabinet should be thoroughly emptied and washed out every three (3) months.

CAUTION: Do not use high pressure hose when cleaning any case. Check the drain outlet to insure it is not clogged before starting to clean and do not introduce water into case faster than the drain can carry it away.

Painted Surface: A mild soap and water solution is recommended for enameled surface. Do not use cleaners containing abrasive ingredients which will scratch or dull finish.

Honeycomb: (Air Discharge) The honeycomb material located in the discharge air nozzles are fragile and care must be exercised to avoid damaging it. The honeycomb should be inspected and cleaned as needed after each six months of service. See page # 2 for further instruction on detecting if honeycomb is dirty or plugged.

Removal of Honeycomb: 2nd guard honeycomb must be removed before attempting to remove 1st guard: Don't attempt to remove plastic extrusion in 1st guard duct as it is sealed in place at the factory. Before removing the 1st guard duct honeycomb remove the three (3) plastic snap-on buttons located along the bottom edge of the nozzle. See (Page 32, fig. #1, item B). Buttons will damage honeycomb if they are not removed before honeycomb is removed. To remove refrigerated and 2nd guard honeycombs, remove stainless steel clips at points "a" and "c". Fig. #1. Then remove honeycomb retainers. (white plastic-wedge type). Points "d," and "f" fig. #1. New honeycomb can be removed and cleaned with compressed air or warm water. Be sure to remove all water from honeycomb cells before reinstalling same. See page 2 for further instructions on removal of honeycomb.

Drain location: Center of cabinet below interior bottom. (bottom is sectional).

Cleaning of Return Air: Remove all tags and other foreign materials from return air grille. (see fig. #2)

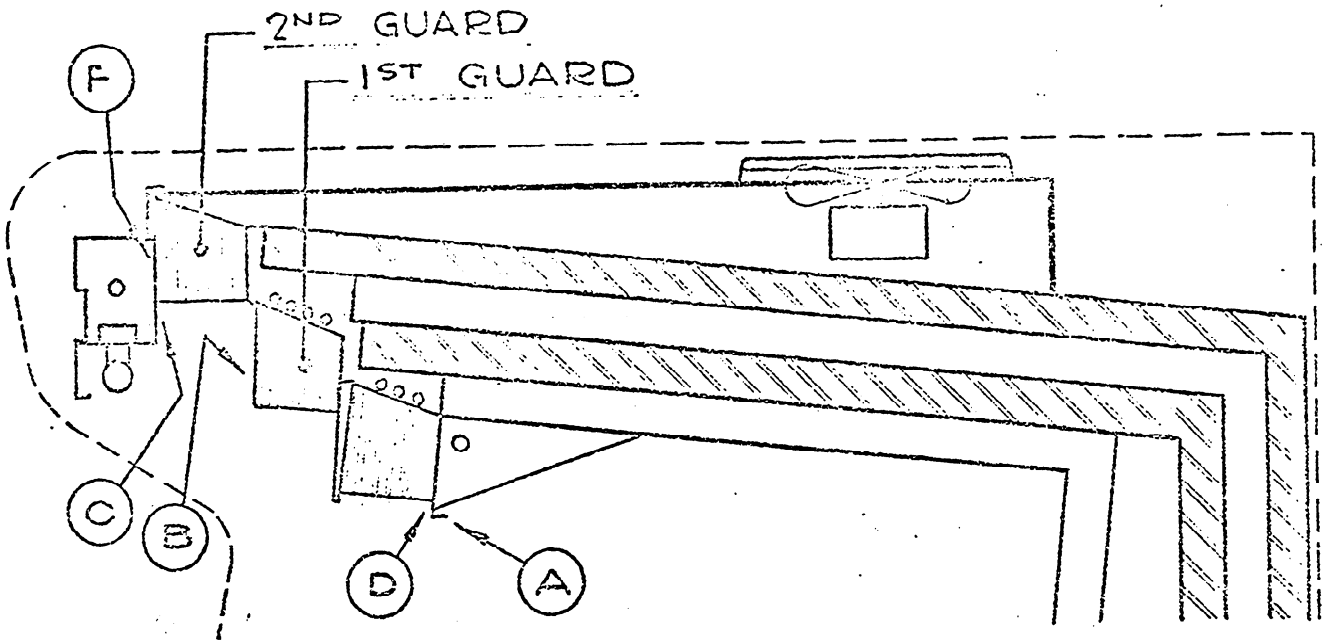

FIG.-1

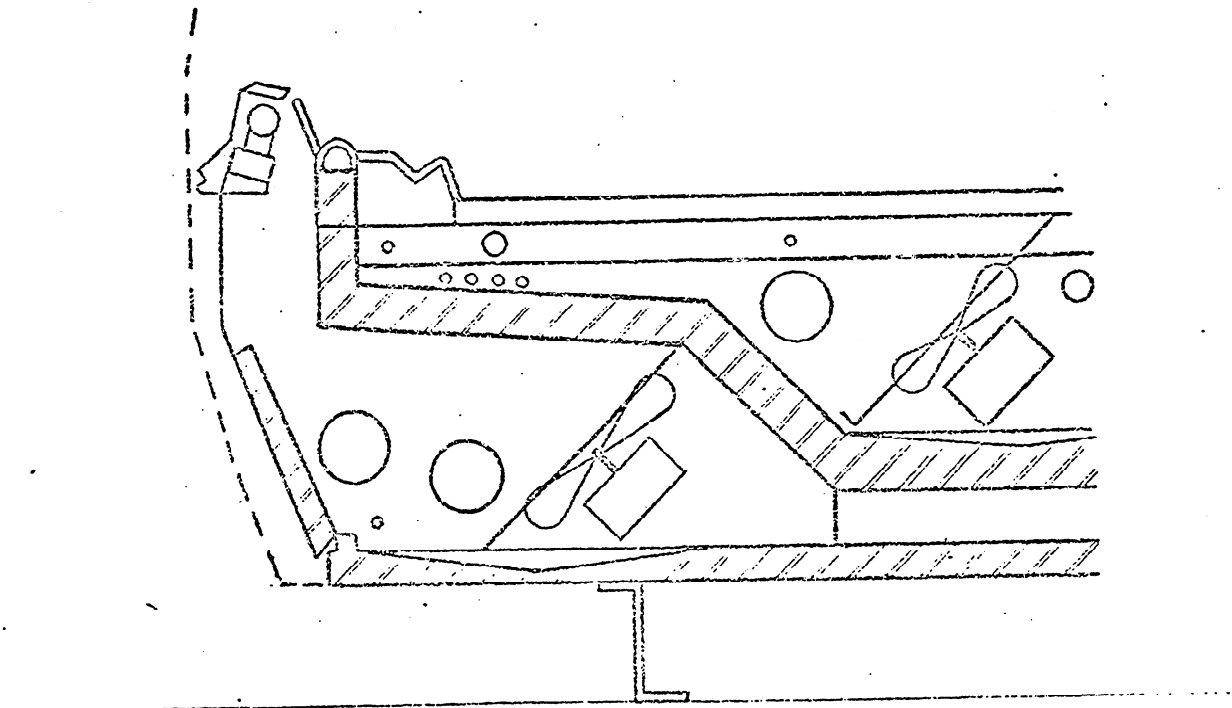

FIG.-2