

INSTALLATION & SERVICE INSTRUCTIONS

FOR MODEL(S)

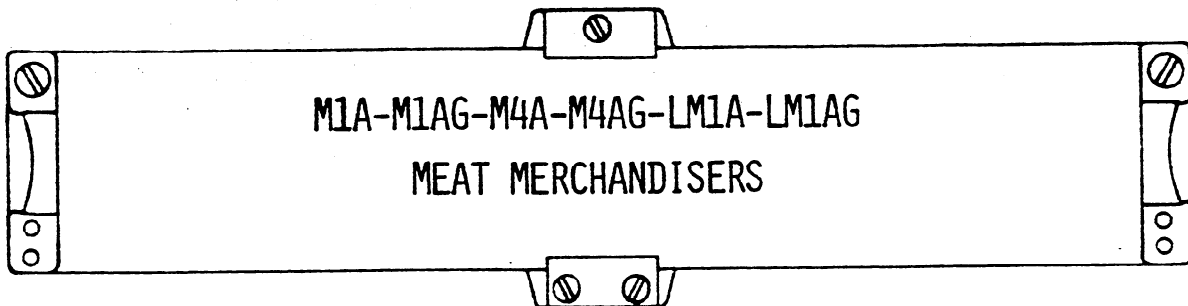

AIR DEFROST
"THE ENERGY MINIMIZER"

**please retain
for future use**

**engineering dept.
bulletin # 75-174-11**

IN THE CONSTANT EFFORT TO IMPROVE OUR PRODUCTS WE
RESERVE THE RIGHT TO CHANGE AT ANY TIME SPECIFICATIONS
DESIGN OR PRICES WITHOUT INCURRING OBLIGATION

KYSOR

P. O. Box C
1600 Industrial Blvd.
Conyers, Georgia 30207
404 483-5600

WARREN / SHERER®

DIVISION OF KYSOR INDUSTRIAL CORPORATION



West Industrial Road
Marshall, Michigan 49068
616 781-3911

INSTALLATION AND OPERATING INSTRUCTIONS

FOR

WARREN/SHERER AIR DEFROST MEAT MERCHANDISERS

Warren/Sherer Air Defrost Meat Merchandisers will display packaged meat under proper storage temperatures. Your refrigerator should be installed and operated according to the following instructions to insure its proper standard of performance.

OUTLINE OF GENERAL DESIGN

These Meat Merchandisers are designed to facilitate self-service. The open top is arranged for refrigerated display so as to give maximum convenience to the customer. Self-service meat merchandisers give full-vision display, and articles stored are within easy reach.

The display case is 8' or 12' long and may be installed in a multi-case line-up with several sections to form continuous fixtures, or they may be installed individually, if so desired. Ends are removable so that additional sections may be added. Mirror canopies and merchandising-shelf canopies are also available.

<u>MODEL</u>	<u>DESCRIPTION</u>	<u>SERIAL NUMBER DESIGNATION</u>
M1A WO/GLASS	Meat Display - Single Display Only/ with Air Defrost	655
M1AG W/GLASS	Meat Display - Single Display Only/ with Air Defrost	653
M4A WO/GLASS	Meat Display - Multi-deck w/two or three shelves above bin display area/ with Air Defrost	654
M4AG W/GLASS	Meat Display - Multi-deck w/two or three shelves above bin display area/ with Air Defrost	656
LM1A WO/GLASS	Frozen Meat Display-Single Display Only/ with Air Defrost	658
LM1AG W/GLASS	Frozen Meat Display-Single Display Only/ with Air Defrost	659

INSTALLATION

LEVELING OF REFRIGERATOR

Your new refrigerator must be perfectly level to insure proper operation of the refrigeration system and also to insure proper drainage after defrost.

Proper leveling when multiplexing can be accomplished by finding the highest point on the floor at the location of the line-up by using a level and a chalk line. Place a refrigerator at this point and use shims as needed to line the other refrigerators to this high point. Be sure sufficient shims are employed so as to prevent settling of the refrigerators.

STORE DRAFTS

Room air currents or drafts will seriously affect the operation of any open-type fixture. Be sure fans, space heaters, or air-conditioning grilles do not produce currents sufficient to move air across the fixtures. Air movements across an open fixture will cause the case temperature to be high and create defrosting difficulties. This will result in an increase of operating costs.

ELECTRICAL

ELECTRICAL CONNECTIONS

Be sure proper voltage is supplied to your refrigerator. Check refrigerator serial plate for fan and anti-condensate and defrost volts. If a canopy is furnished, use a separate fused circuit. ALL REFRIGERATORS MUST BE GROUNDED.

When multiplexing refrigerators to one 115V electrical source, the total case fan, defrost fan, and anti-condensate amperes must be added together, and proper wire size and branch circuit fuse or circuit breaker as required by the National Electric Code must be employed. THIS CIRCUIT MUST BE RUN CONTINUOUSLY AND MUST BE MARKED sufficiently to prevent the fan motors and anti-condensate from being turned off accidentally.

The 208/230V defrost relay holding coil is 0.005 amps per condensing unit. Be sure that proper wire size and branch circuit fuses are employed to give safe operation.

Chart 1 shows the electrical ratings for your refrigerator. This is the same information that appears on your refrigerator nameplate.

CHART 1

MODEL	EVAPORATOR FAN AND GUARD JET FAN AMPS		ANTI-CONDENSATE AMPS		DEFROST FAN AMPS	
	115 VOLTS		115 VOLTS		115 VOLTS*	
M1A-8	.90		.66		2.9	
M1A-12	.90		.9		2.9	
M1AG-8	.90		.9		2.9	
M1AG-12	.90		1.08		2.9	
M4A-8	2.25		.63		2.9	
M4A-12	3.60		.85		5.8	
M4AG-8	2.25		.82		2.9	
M4AG-12	3.60		1.06		5.8	
LM1A-8	.90		1.3		2.9	
LM1A-12	.90		1.5		2.9	
LM1AG-8	.90		2.1		2.9	
LM1AG-12	.90		2.5		2.9	

M4A(G) 8FT - 2.54 Amps For each lighted shelf (except the
115V Lights 12FT - 3.61 Amps standard bottom shelf already in-
cluded) add .67amps per 4 feet.

*For 208/230 volts defrost relay holding coil supply single phase control line from time clock for each condensing unit.

All lighted canopies should be on a separate fused circuit, and the amperages shown on Chart 2 should be used in calculating the proper wire and circuit fuse size.

CHART 2

CANOPY MODEL	LIGHTED SUPERSTRUCTURE		LIGHTED SHELVES		TOTAL LIGHT AMPS	
	8FT.	12FT.	8FT.	12FT.	8FT.	12FT.
CM (1 shelf)	-	-	1.34	2.01	1.34	2.01
CM (2 shelves)	-	-	2.68	4.02	2.68	4.02
CMT (1 shelf)	1.34	2.01	1.34	2.01	2.68	4.02
CMT (2 shelves)	1.34	2.01	2.68	4.02	4.02	6.03
CS68, CT68	1.34	2.01			1.34	2.01

NOTE: If all shelves do not carry lights, disregard LIGHTED SHELVES column and use .67 amperes for each 4-foot lighted shelf.

FAN MOTORS

The fan motors employed are permanently oiled for the life of the motor and require no periodic maintenance. These are to be wired according to the enclosed wiring diagram. Case fans run continuously; defrost fans run during defrost period.

The case fan blade will turn counterclockwise when looking into the refrigerator. The case fan blade must have its rib facing the motor for proper operation. The defrost fans are squirrel cage type blowers.

ANTI-CONDENSATE HEATERS

Anti-condensate heaters are placed in the refrigerator at certain points to insure against condensation forming on the refrigerator under normal conditions. The pictorial view shows the location of these necessary heaters.

If replacement of an anti-condensate heater should ever be necessary the following steps should be followed:

To Replace Rear Tag Rail Anti-Condensate Heater: Ref. (4) M1A(G)
LM1A(G)

1. Remove air grille spring clip and then remove air grille by tilting forward.
2. Remove price-tag moulding.
3. Remove top back joint or end trim.
4. Remove top back stainless steel panel access cover.
5. Disconnect heater from main wiring harness.
6. Remove heater pan.

To Replace Front Rail Heater: Ref (8A) M1A(G), LM1A(G)
(15A)M4A(G)

1. Remove joint trim.
2. Remove color band, thermopane base trim, and top rail cap.
3. Disconnect heater from Full-View jumper.
4. Remove anti-condensate heater.

To Replace Honeycomb Anti-Condensate Heater: Ref (7) M4A(G)

1. Remove rear honeycomb retainer.
2. Remove honeycomb.
3. Disconnect heater wire.
4. Remove heater from rail extrusion.

DEFROST CONTROLS

The defrost fans are initiated by a time clock at the condensing unit control panel which energizes the relay at the case to supply 115 volts to the fans. A 208/230 volt control wire from time clock to relay holding coil is required. Defrost is terminated by a therm-o-disc (45°) attached to the evaporator coil. Control wiring from the therm-o-disc to time clock should be wired as shown on the wiring diagram.

ELECTRICAL RACEWAY

An electrical raceway is furnished with each refrigerator for running the fan and lighting control circuits from case to case without using conduit. This applies, of course, when the front panel is properly secured into position. This is approved by the Underwriters Laboratories and may or may not comply with local codes.

OPERATION

For M1 and M4 meat merchandisers, either a thermostat or low-pressure control can be used to obtain proper temperature. When a condensing unit is subjected to low ambients during the winter months, a thermostat might be necessary. The thermostat bulb should be mounted in the return air close to an evaporator fan.

Chart 3 below shows approximate setting for single-duty and high back merchandisers. Since many variables are present in each installation, such as store temperature, length of tubing runs, temperature desired in refrigerator, etc., the chart below is only a guide for the installer. Final adjustments should be made to meet the local conditions and requirements.

CHART 3

	<u>REFRIGERANT</u>	<u>LOW PRESSURE</u>		<u>THERMOSTAT</u>		<u>HIGH-</u>
		<u>CUT-OUT</u>	<u>CUT-IN</u>	<u>CUT-OUT</u>	<u>CUT-IN</u>	<u>PRESSURE</u>
						<u>CUT-OUT</u>
						<u>MAXIMUM</u>
Deli Products	R-12	16 psi	27 psi			
	R-502	44 psi	63 psi			
Fresh Meat	R-12	13 psi	27 psi	30°	34°	200 psi
	R-502	39 psi	63 psi	30°	34°	340 psi
Frozen Meat	R-502	39 psi	63 psi	-50°	0°	340 psi

When using thermostats, lower the low-pressure control cut-out below the setting above, so as to make sure the thermostat is the controlling device.

LOAD LINE

For proper operation, you must not stack merchandise above the air outlet and air return grilles. In doing so, you will seriously affect the performance of the refrigerator, which will result in higher temperature of the merchandise stored within. Therefore, IT IS ESSENTIAL THAT MERCHANDISE IS NOT STORED ABOVE THESE POINTS.

WASTE OUTLET CONNECTIONS

All M1 and M4 meat merchandisers are equipped with a 1-1/2" (nominal 2") FPT waste outlet connection which terminates in the center of the refrigerator below the insulated bottom. An open drip space in drip pipe between case and sewer connection is recommended. CAUTION: Drain trap is built-in, if auxiliary drain trap is used remove internal bell trap from drain strainer. Improper drainage can result if a double trap exists.

IMPORTANT

Before loading the refrigerator, be sure to check all access plates and be sure they are thoroughly sealed, and the rubber on the bottom of the plenum chamber is sealed firmly to the bottom.

DEFROSTING

These Warren/Sherer meat merchandisers have air defrost as standard. The evaporator fans run continuously. Defrost fans are initiated by time clock and terminated by a therm-o-disc thermostat set for 45°F. The time clock should be set to fail safe at 20 min. for deli and fresh meat products and 30 min. for frozen meats. Three defrost per day are required for normal conditions. When high humidity exist it may be necessary to increase to four times per day.

HOT GAS DEFROST (ACCESSORY)

Reverse cycle defrost kits are offered as an accessory and are installed at the factory. Reverse cycle hot gas defrost is not recommended above air defrost but may be specified when using Dual-Metic type condensing units. Control settings are the same as for air defrost.

REFRIGERATION

EXPANSION VALVE

The expansion valve furnished with your refrigerator has been carefully sized and set for maximum coil efficiency. This bulb is located on the outlet of the coil. This location **MUST NOT BE CHANGED**. Due to local conditions, adjustment of the thermostatic expansion valve may be necessary after a minimum of 6 hours operation. Do not adjust the expansion valve at this point until you have checked the inlet strainer. If adjustment is necessary, adjust valve to give frost line to ferrule hole where suction line exits the refrigerator. Adjust expansion valve 1/4 turn and wait for 30 minutes before making final check.

REFRIGERANT LINES

On Warren/Sherer meat merchandisers, the liquid and suction lines are located to the right of case center in the bottom area. The suction line is 5/8"OD for M1, LM1, and 7/8"OD for M4, and the liquid line is 3/8"OD. The tubing faces forward so that an elbow may be used, or if multiplexing a tee can be used. Be sure all refrigerant lines lie as close to the refrigerator bottom as possible so as not to obstruct the return-air section of the refrigerator.

REFRIGERANT

Refrigerant R-502 is optional except for LM1A(G), where R-502 is mandatory. The customer's order must specify the refrigerant to be employed so the proper expansion valve can be supplied with refrigerator.

HEAT EXCHANGER

The heat exchanger incorporated in the refrigerator was sized to give maximum efficiency to the refrigeration system.

The heat exchanger uses the heat of the incoming liquid refrigerant to raise the temperature of the return suction gas temperature.

The heat exchanger increases the over-all capacity of the refrigeration system and aids in the evaporation of any liquid refrigerant entrained in the suction gases, thereby preventing "flood-back" to the compressor.

DEHYDRATION OF REFRIGERATION SYSTEM

PLEASE READ CAREFULLY BEFORE PLACING SYSTEM INTO OPERATION

1. After laying refrigerant lines, they should be blown out before making final connection at fixture or condensing unit. Use either carbon dioxide or dry nitrogen to prevent any foreign matter being left in the lines. Keep pressure below 250 pounds.
2. To prevent scaling due to brazing, dry nitrogen should be allowed to flow through lines while brazing operations are taking place.
3. After installation is complete and checked for leaks, pump a deep vacuum using a vacuum pump. DO NOT USE THE CONDENSING UNIT FOR THIS PURPOSE...
4. Break vacuum on system by releasing refrigerant through a dehydrator until pressure gauge reads above zero pounds. Repeat steps three and four.
5. A dehydrator should be used in the charging line when adding refrigerant.
6. A dehydrator of sufficient capacity must be installed in the liquid line before placing system into operation.

11

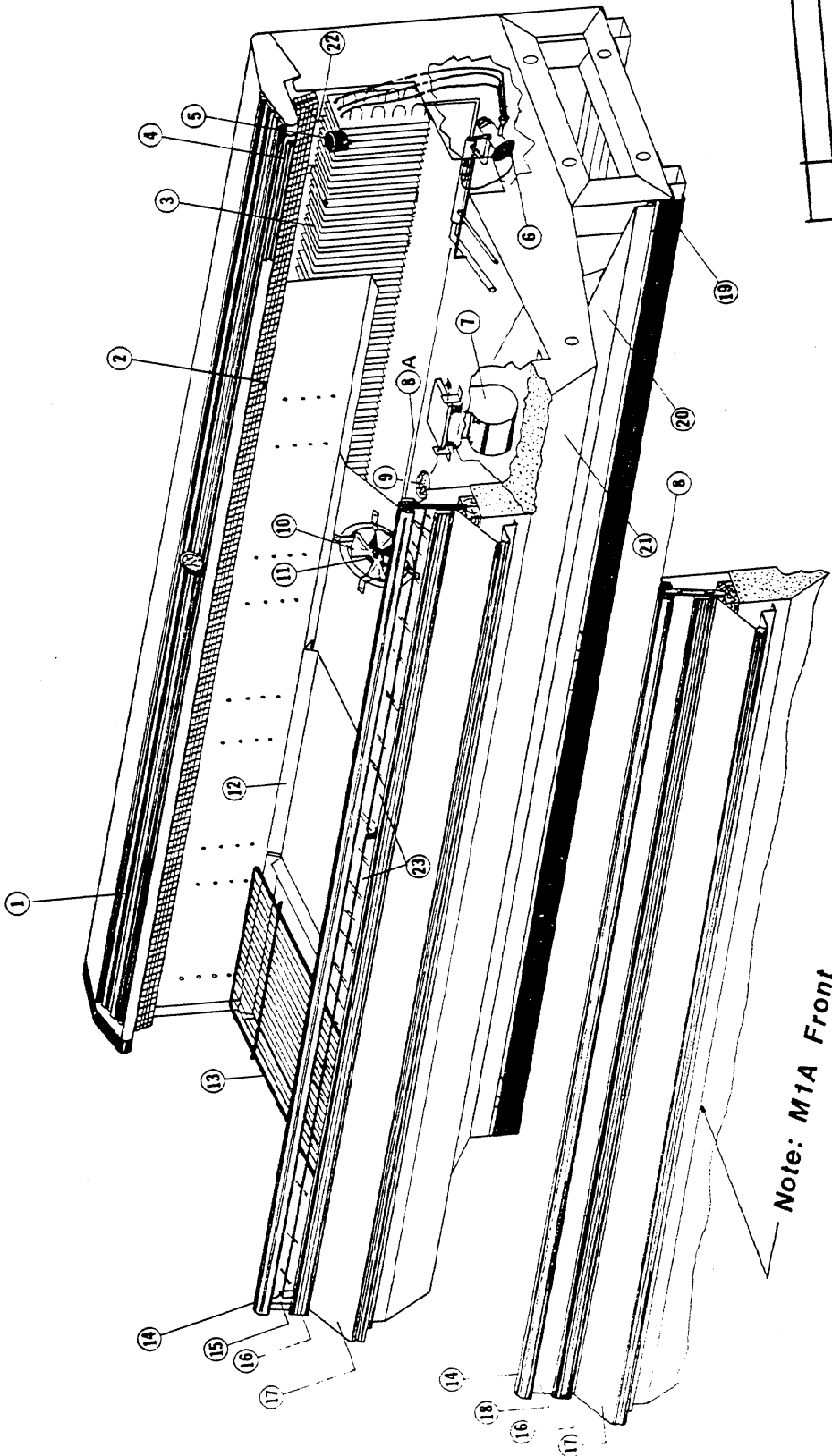

Note: M1A Front

LETTER	REVISED	DATE	BY
TITLE M1A(G) PICTORIAL VIEW FOR SERVICE MANUAL			
NO. 24-75	DRAWING NUMBER PB-20735		
SCALE NONE	DRAWN BY SHENEN		
DRAWN BY TIM ADAMS	SHEREN INDUSTRIAL CORPORATION		
APP'D. B. SMITH	DIVISION OF INDUSTRIAL CORPORATION		
	P. O. BOX 1138, ALBANY, GEORGIA 31701		

PART DESCRIPTION	REF. NO.	M4A(G)	
		8'	12'
MOTOR	1	9A10-17	9A10-17
FAN BLADE	2	9B10-13	9B10-13
REFR. JET HONEYCOMB	3	16A16-22	16A16-22
ROOM AIR HONEYCOMB	4	16A16-21	16A16-21
LAMP HOLDER	5	10B11-20	10B11-20
F96T12N HO NATURAL BULB	6	10A10-48	10A10-47
HEATER EXTRUSION ASSY	7	81C10-76	81C11-76
CANOPY FRONT PANEL	8	51C12-49	51C14-45
BALLAST	9	10D10-27	10D10-27
LAMP HOLDER	10	10B11-19	10B11-19
THERMOSTAT THERM-O-DISC	11	8A11-26	8A11-26
32 TUBE COIL	12	5A20-34	5A20-35
EXPANSION VALVE	13	3A12-21	3A14-22
SQUIRREL CAGE BLOWER	14	28D12-12	28D12-12
TOP RAIL ANTI-SWEAT HEATER+	15	81A12-50	81A14-49
THERMOPANE ANTI-SWEAT HEATER*	15A	81A12-34	81A14-34
MOTOR	16	9A10-17	9A10-17
FAN BLADE	17	9B10-13	9B10-13
WIRING HARNESS	18	10M10-120	10M10-120
DECK PAN	19	54N18-115	54N18-115
ADJ. WIRE RACK	20	28G19-130	28G19-130
20" BTM SHLF SLOPE W/LT & DF	21	96F17-419	96F17-419
SHELF AIR DEFLECTOR	22	54P13-242	54P13-242
THERMOPANE CAP	23	15J11-19	15J11-21
THERMOPANE GLASS*	24	14D10-29	14D10-30
THERMOPANE BASE TRIM	25	15J11-10	15J11-12
COLORBAND PAINTED	26	51A17-33	51A19-33
KICKPLATE PAINTED	27	51A12-87	51A14-76
TOP FRONT SS PLATE +	28	55F22-20	55F23-19
LOWER FRONT PANEL	29	51A12-86	51A14-74
UPPER FRONT PANEL	30	51A12-85	51A14-75
DRAIN TRAP ASSY	31	56L14-88	56L14-88

*Glass Model Only
+Non Glass Model

11

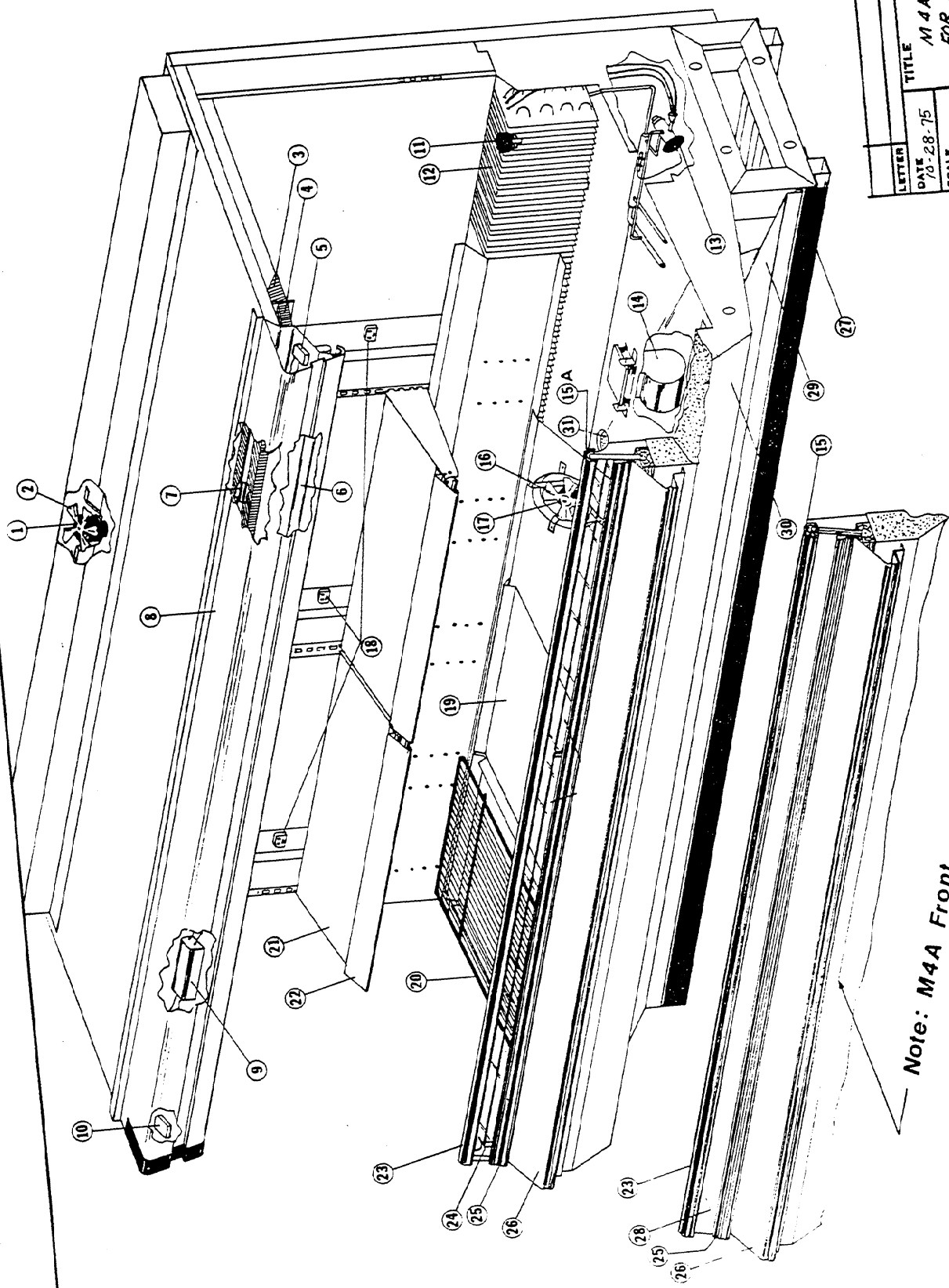

LETTER	REVISED	DATE	BY
TITLE		DRAWING NUMBER	
M4A(G) PICTORIAL VIEW FOR SERVICE MANUAL		PB-20736	
DATE	SCALE	DRAWN	APPD.
70-28-75	ADAMS	TOM ADAMS	C. SMITH
DESIGNED BY		CHECKED BY	
LUMBER / GHEMER		GHEMER	
DIVISION OF KYOCER INDUSTRIAL CORPORATION P. O. BOX 1218, ALBUQUERQUE, GEORGIA 30181			

Note: M4A Front

JOINT KIT NO 94A13-454 FOR MODELS M1A

PART NUMBER	DRAWING LETTER	DESCRIPTION	REQ'D
16F10-57	A	CASTING - JOINT TRIM	1
51F11-100	B	TRIM - LOWER FRONT PANEL	1
51F11-101	C	TRIM - UPPER FRONT PANEL JOINT	1
51F11-102	D	TRIM - KICKPLATE JOINT	1
54L20-50	E	TRIM - REAR BAFFLE JOINT	1
55P12-100	F	TRIM - COLORBAND JOINT	1
55P13-256	G	TRIM - TOP CAP JOINT	1
56F18-137	H	CHANNEL - JOINT DRIP	1
*53E16-49		TRIM - LOWER FRONT PANEL JOINT VINYL	1
*53F16-50		TRIM - UPPER FRONT PANEL JOINT VINYL	1
*55P18-94		TRIM - KICKPLATE SS	1
19A15-13		NUT - 3/8 SQ HD TEE SMALL	4
19B13-11		WASHER - 3/8 CUT SCP	4
20E10-17		3/8-16 x 2 HEX HEAD MACHINE BOLT	4
21A11-33		SCREW - #8-32 x 3/4 SMS	8
21B11-19		SCREW - #8 x 5/8 SMS	18
21B12-17		SCREW - #10-16 x 1/2 SD SMS	2

*Accessory Parts

NOTES:

- FOR SIMPLIFICATION, PLACE FIXTURES AS NEAR THEIR PERMANENT LOCATION AS POSSIBLE BEFORE REMOVING SKIDS OR ROLLERS.
- THE LEVELING OF FIXTURES IS VERY IMPORTANT. SKILLED PERSONNEL AND AN ACCURATE LEVEL MUST BE USED. WOODEN WEDGES ARE FURNISHED TO ASSIST IN THIS OPERATION.
- AN AMPLE SUPPLY OF 1/4" ROUND SEALING COMPOUND IS SENT WITH EACH MULTIPLE INSTALLATION FOR SEALING OFF ANY AIR LEAKAGE. IT IS ESSENTIAL THAT ALL AIR LEAKS BE SEALED IN ORDER TO PREVENT OPERATING DIFFICULTIES. REMOVE ANY EXCESS SEALING COMPOUND WITH A SOLVENT SUCH AS MINERAL SPIRITS.
- FIXTURES ARE TO BE PLACED END TO END AS CLOSELY AND AS NEAR IN LINE AS POSSIBLE. TO LOCATE UPPER REAR PULL IN-LINE HOLE. REMOVE END PLASTIC DISCHARGE GRILLES. PLACE SMALL T-NUTS INTO PRE-DRILLED HOLES LOCATED IN END FRAMES. ROTATE 3/8" BOLTS WITH T-NUT WASHERS INTO T-NUTS ALTERNATELY UNTIL JOINT IS COMPLETE SEALED. POSITION TRIM AS SHOWN USING PARTS LIST DRAWING LETTERS AS A GUIDE.
- "F" COLORBAND JOINT TRIM PLACE COLORBAND JOINT TRIM OVER THERMOPANE TRIM. SECURE WITH TWO #8 x 5/8 SHEET METAL SCREWS (SMS).
- "A" JOINT TRIM CASTING POSITION CASTING OVER BOTTOM OF COLORBAND JOINT TRIM AND SECURE WITH EIGHT #8-32 x 3/4 SMS.
- FRONT PANEL TRIM "B" & "C" LOWER TRIM "B" MUST BE INSTALLED FIRST. LOCATE IT AND FASTEN WITH TWO #8 x 5/8 SMS. PLACE UNDER TRIM "C" IN PLACE AND INSTALL FOUR #8 x 5/8 SMS.
- TOP CAP JOINT TRIM "G" HOOK TOP CAP TRIM OVER FRONT EDGE OF TOP CAP AND PUSH REAR DOWN UNTIL TRIM COMES INTO LINE. FASTEN WITH SIX #8 x 5/8 SMS.
- REAR BAFFLE JOINT TRIM "E" POSITION TRIM AND FASTEN WITH FOUR #8 x 5/8 SMS.
- JOINT DRIP CHANNEL "H" THE JOINT DRIP CHANNEL SEALS THE GAP CREATED BY THE JOINTING OF THE TWO END FRAMES. CENTER THE CHANNEL AND SLIP OVER THE FRAME.
- KICKPLATE JOINT TRIM "D" POSITION AND FASTEN WITH TWO #10-16 x 1/2 SMS.

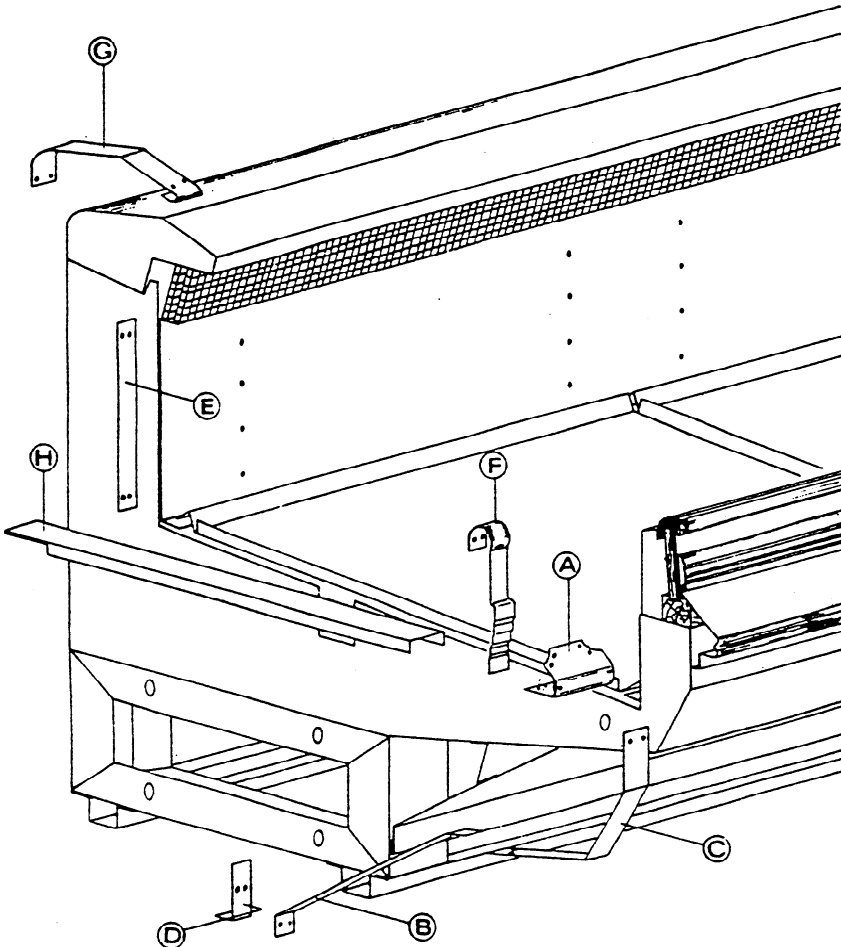

JOINT KIT N^o 94A13-455 FOR MODELS M1A G

PART NUMBER	DRAWING LETTER	DESCRIPTION	REQ'D
16F10-57	A	CASTING - JOINT TRIM	1
51F11-100	B	TRIM - LOWER FRONT PANEL	1
51F11-101	C	TRIM - UPPER FRONT PANEL JOINT	1
51F11-102	D	TRIM - KICKPLATE JOINT	1
54I20-50	E	TRIM - REAR BAFFLE JOINT	1
55P12-101	F	TRIM - COLORBAND JOINT	1
55P13-256	G	TRIM - TOP CAP JOINT	1
56F18-137	H	CHANNEL - JOINT DRIP	1
*53E16-49		TRIM - LOWER FRONT PANEL JOINT VINYL	1
*53E16-50		TRIM - UPPER FRONT PANEL JOINT VINYL	1
*55P18-94		TRIM - KICKPLATE SS	1
19A15-13		NUT - 3/8 SQ HD TEE SMALL	4
19B13-11		WASHER - 3/8 CUT SCP	4
20E10-17		3/8-16 x 2 HEX HEAD MACHINE BOL	4
21A11-33		SCREW - #8-32 x 3/4 SMS	8
21B11-19		SCREW #8 x 5/8 SMS	18
21B12-17		SCREW - #10-16 x 1/2 SD SMS	2

NOTES:

- FOR SIMPLIFICATION, PLACE FIXTURES AS NEAR THEIR PERMANENT LOCATION AS POSSIBLE BEFORE REMOVING SKIDS OR ROLLERS.
- THE LEVELING OF FIXTURES IS VERY IMPORTANT. SKILLED PERSONNEL AND AN ACCURATE LEVEL MUST BE USED. WOODEN WEDGES ARE FURNISHED TO ASSIST IN THIS OPERATION.
- AN AMPLE SUPPLY OF 1/4" ROUND SEALING COMPOUND IS SENT WITH EACH MULTIPLE INSTALLATION FOR SEALING OFF ANY AIR LEAKAGE. IT IS ESSENTIAL THAT ALL AIR LEAKS BE SEALED IN ORDER TO PREVENT OPERATING DIFFICULTIES. REMOVE ANY EXCESS SEALING COMPOUND WITH A SOLVENT SUCH AS MINERAL SPIRITS.
- FIXTURES ARE TO BE PLACED END TO END AS CLOSELY AND AS NEAR IN LINE AS POSSIBLE. TO LOCATE UPPER REAR PULL IN-LINE HOLE. REMOVE END PLASTIC DISCHARGE GRILLES. PLACE SMALL T-NUTS INTO PRE-DRILLED HOLES LOCATED IN END FRAMES. ROTATE 3/8" BOLTS WITH T-NUT WASHERS INTO T-NUTS ALTERNATELY UNTIL JOINT IS COMPLETELY SEALED. POSITION TRIM AS SHOWN USING PARTS LIST DRAWING LETTERS AS A GUIDE.
- "F" COLORBAND JOINT TRIM. PLACE COLORBAND JOINT TRIM OVER THERMOPANE TRIM. SECURE WITH TWO #8 x 5/8 HEET METAL SCREWS (SMS).
- "A" JOINT TRIM CASTING POSITION CASTING OVER BOTTOM OF COLORBAND JOINT TRIM AND SECURE WITH EIGHT #8-32 x 3/4 SMS.
- FRONT PANEL TRIM "B" & "C" LOWER TRIM "B" MUST BE INSTALLED FIRST. LOCATE IT AND FASTEN WITH TWO #8 x 5/8 SMS. PLACE UPPER TRIM "C" IN PLACE AND INSTALL FOUR #8 x 5/8 SMS
- TOP CAP JOINT TRIM "G" HOOK TOP CAP TRIM OVER FRONT EDGE OF TOP CAP AND PUSH REAR DOWN UNTIL TRIM COMES INTO LINE. FASTEN WITH SIX #8 x 5/8 SMS.
- REAR BAFFLE JOINT TRIM "E" POSITION TRIM AND FASTEN WITH FOUR #8 x 5/8 SMS.
- JOINT DRIP CHANNEL "H" THE JOINT DRIP CHANNEL SEALS THE GAP CREATED BY THE JOINTING OF THE TWO END FRAMES. CENTER THE CHANNEL AND SLIP OVER THE FRAME.
- KICKPLATE JOINT TRIM "D" POSITION AND FASTEN WITH TWO #10-16 x 1/2 SMS.

*Accessory Part

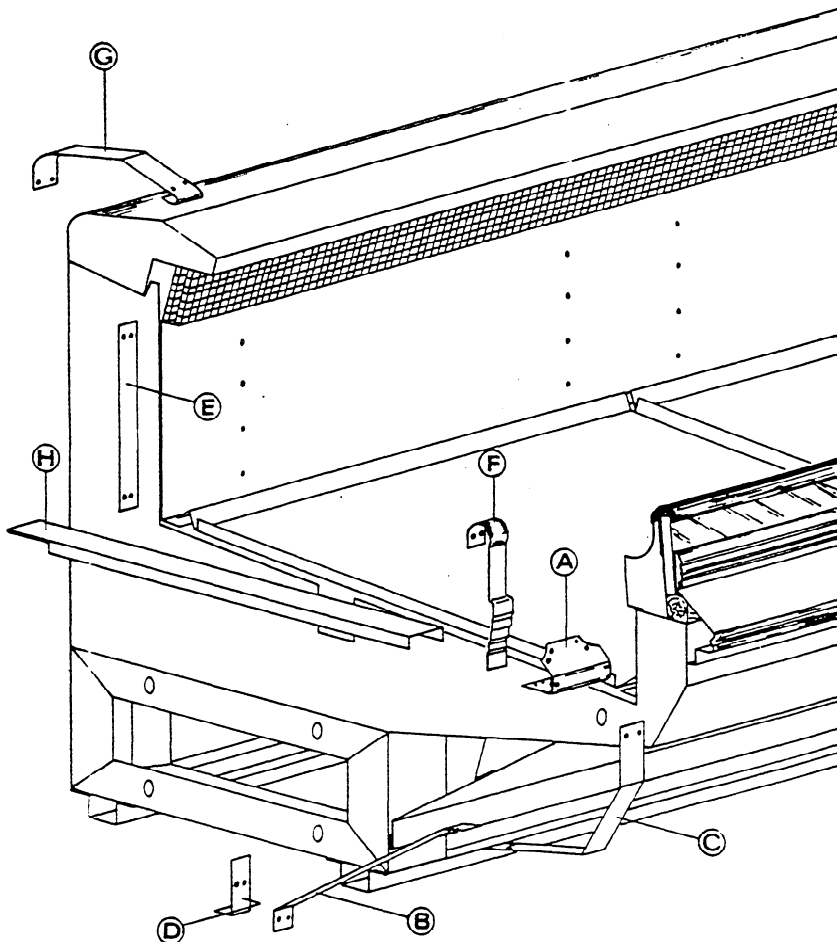

JOINT KIT N^o 94D13-110 FOR MODELS M4A

PART NUMBER	DRAWING LETTER	DESCRIPTION	REQ'D
16F10-57	A	CASTING - JOINT TRIM	1
51F11-100	B	TRIM - LOWER FRONT PANEL JOINT	1
51F11-101	C	TRIM - UPPER FRONT PANEL JOINT	1
51F11-102	D	TRIM - KICKPLATE JOINT	1
51F11-103	E	TRIM - CANOPY JOINT	1
51X16-52	F	TRIM - ROOM AIR FAN PLENUM	1
54L20-49	G	TRIM - REAR BAFFLE JOINT	1
55P12-100	H	TRIM - COLORBAND JOINT	1
56F18-138	I	CHANNEL - JOINT DRIP	1
56F18-139	J	TRIM - HEATER RAIL EXTRUSION JOINT	1
*53F16-49		TRIM - LOWER FRONT PANEL JOINT VINYL	1
*53F16-50		TRIM - UPPER FRONT PANEL JOINT VINYL	1
*53F16-51		TRIM - CANOPY JOINT VINYL	1
*55P18-94		TRIM - KICKPLATE SS	1
19A15-13		NUT - 3/8 SO HD TEE SMALL BOLT	6
19B13-11		WASHER - 3/8 CUT SCP	6
20F10-17		3/8-16 x 2 HEX HEAD MACHINE BOLT	6
21A11-33		SCREW - #8-32 x 3/4 SMS	8
21B11-12		#8 x 3/4 SMS	4
21B11-19		#8 x 5/8 SMS	14
21B12-17		#10-16 x 1/2 SMS	6

*Accessory Parts

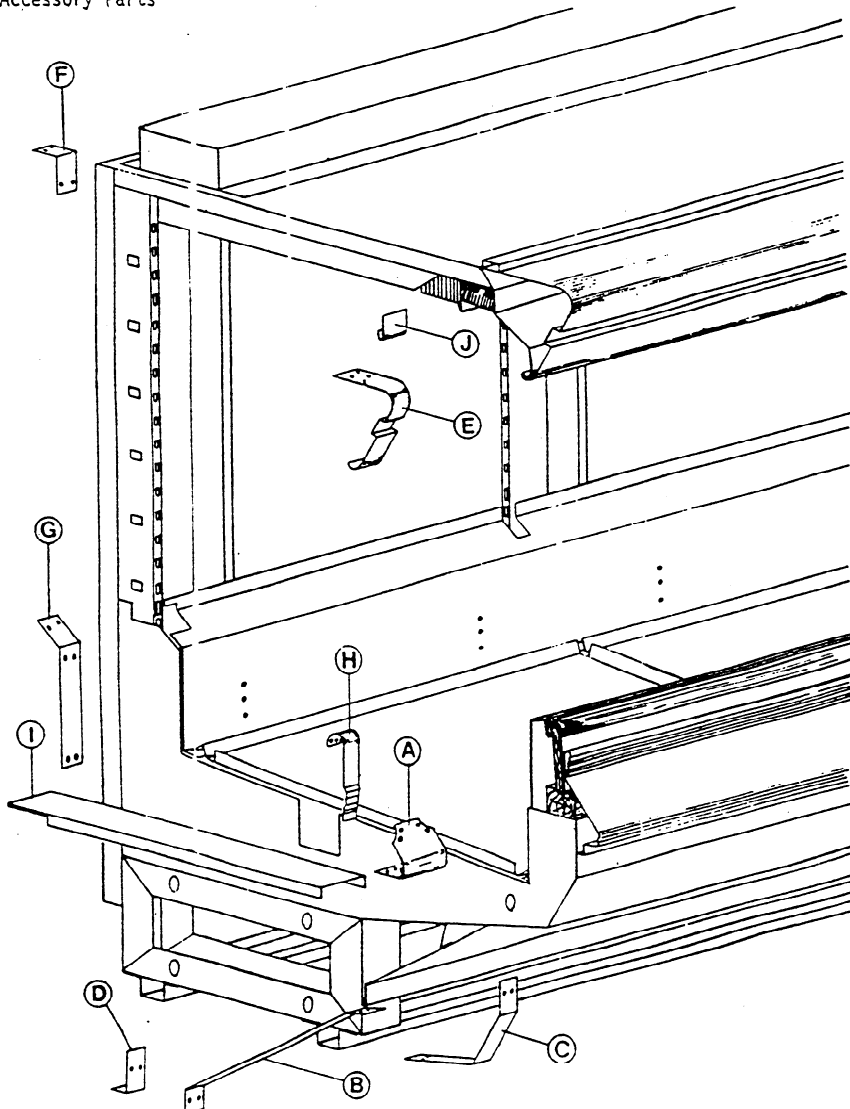

NOTES:

- FOR SIMPLIFICATION, PLACE FIXTURES AS NEAR THEIR PERMANENT LOCATION AS POSSIBLE BEFORE REMOVING SKIDS OR ROLLERS.
- THE LEVELING OF FIXTURES IS VERY IMPORTANT. SKILLED PERSONNEL AND AN ACCURATE LEVEL MUST BE USED. WOODEN WEDGES ARE FURNISHED TO ASSIST IN THIS OPERATION.
- AN AMPLE SUPPLY OF 1/4" ROUND SEALING COMPOUND IS SENT WITH EACH MULTIPLE INSTALLATION FOR SEALING OFF ANY AIR LEAKAGE. IT IS ESSENTIAL THAT ALL AIR LEAKS BE SEALED IN ORDER TO PREVENT OPERATING DIFFICULTIES. REMOVE ANY EXCESS SEALING COMPOUND WITH A SOLVENT SUCH AS MINERAL SPIRITS.
- FIXTURES ARE TO BE PLACED END TO END AS CLOSELY AND AS NEAR IN LINE AS POSSIBLE. PLACE SMALL T-NUTS INTO PRE-DRILLED HOLES LOCATED IN END FRAMES. ROTATE 3/8" BOLTS WITH T-NUT WASHERS INTO T-NUTS ALTERNATELY UNTIL JOINT IS COMPLETELY SEALED. POSITION TRIM AS SHOWN USING PARTS LIST DRAWING AS A GUIDE.
- "H" COLORBAND JOINT TRIM PLACE COLORBAND JOINT TRIM OVER THERMOPANE TRIM. SECURE WITH TWO #8 x 5/8 SHEET METAL SCREWS (SMS).
- "A" JOINT TRIM CASTING POSITION CASTING OVER BOTTOM OF COLORBAND JOINT TRIM AND SECURE WITH EIGHT #8-32 x 3/4 SMS.
- FRONT PANEL TRIM "B" & "C" LOWER TRIM "B" MUST BE INSTALLED FIRST. LOCATE IT AND FASTEN WITH TWO #8 x 5/8 SMS. PLACE UPPER TRIM "C" IN PLACE AND INSTALL FOUR #8 x 5/8 SMS.
- REAR BAFFLE JOINT TRIM "G" POSITION TRIM AND FASTEN WITH FOUR #8 x 5/8 SMS
- JOINT DRIP CHANNEL "I" THE JOINT DRIP CHANNEL SEALS THE GAP CREATED BY THE JOINTING OF THE TWO END FRAMES. CENTER THE CHANNEL AND SLIP OVER THE FRAME.
- KICKPLATE JOINT TRIM "D" POSITION AND FASTEN WITH TWO #10-16 x 1/2 SMS.
- CANOPY JOINT TRIM "E" HOOK LOWER EDGE OF CANOPY JOINT TRIM INTO PLACE & PUSH TO THE REAR. FASTEN WITH FOUR #8 x 3/4 SMS.
- ROOM AIR FAN PLENUM TRIM "F" POSITION AND INSTALL WITH FOUR #8 x 5/8 SMS.

JOINT KIT N^o 94D13-111 FOR MODELS M4A G

PART NUMBER	DRAWING LETTER	DESCRIPTION	REQ'D
16F10-57	A	CASTING - JOINT TRIM	1
51F11-100	B	TRIM - LOWER FRONT PANEL JOINT	1
51F11-101	C	TRIM - UPPER FRONT PANEL JOINT	1
51F11-102	D	TRIM - KICKPLATE JOINT	1
51F11-103	E	TRIM - CANOPY JOINT	1
51X16-52	F	TRIM - CANOPY JOINT	1
54I20-49	G	TRIM - REAR BAFFLE JOINT	1
55P12-101	H	TRIM - COLORBAND JOINT	1
56F18-138	I	CHANNEL - JOINT DRIP	1
56F18-139	J	TRIM - HEATER RAIL EXTRUSION JOINT	1
*53E16-49		TRIM - LOWER FRONT PANEL JOINT VINYL	1
*53E16-50		TRIM - UPPER FRONT PANEL JOINT VINYL	1
*53E16-51		TRIM - CANOPY JOINT VINYL	1
*55P18-94		TRIM - KICKPLATE SS	1
19A15-13		NUT - 3/8 SQ HD TEE SMALL BOLT	6
19B13-11		WASHER - 3/8 CUT SCP	6
20E10-17		3/8 - 16 x 2 HEX HEAD MACHINE BOLT	6
21A11-33		SCREW - #8-32 x 3/4 SMS	8
21B11-12		#8 x 3/4 SMS	4
21B11-19		#8 x 5/8 SMS	14
21B12-17		#10-16 x 1/2 SMS	6

NOTES:

- FOR SIMPLIFICATION, PLACE FIXTURES AS NEAR THEIR PERMANENT LOCATION AS POSSIBLE BEFORE REMOVING SKIDS OR ROLLERS.
- THE LEVELING OF FIXTURES IS VERY IMPORTANT. SKILLED PERSONNEL AND AN ACCURATE LEVEL MUST BE USED. WOODEN WEDGES ARE FURNISHED TO ASSIST IN THIS OPERATION.
- AN AMPLE SUPPLY OF 1/4" ROUND SEALING COMPOUND IS SENT WITH EACH MULTIPLE INSTALLATION FOR SEALING OFF ANY AIR LEAKAGE. IT IS ESSENTIAL THAT ALL AIR LEAKS BE SEALED IN ORDER TO PREVENT OPERATING DIFFICULTIES. REMOVE ANY EXCESS SEALING COMPOUND WITH A SOLVENT SUCH AS MINERAL SPIRITS.
- FIXTURES ARE TO BE PLACED END TO END AS CLOSELY AND AS NEAR IN LINE AS POSSIBLE. PLACE SMALL T-NUTS INTO PRE-DRILLED HOLES LOCATED IN END FRAMES. ROTATE 3/8" BOLTS WITH T-NUT WASHERS INTO T-NUTS ALTERNATELY UNTIL JOINT IS COMPLETELY SEALED. POSITION TRIM AS SHOWN USING PARTS LIST DRAWING AS A GUIDE.
- "H" COLORBAND JOINT TRIM PLACE COLORBAND JOINT TRIM OVER THERMOPANE TRIM. SECURE WITH TWO #8 x 5/8 SHEET METAL SCREWS (SMS).
- "A" JOINT TRIM CASTING POSITION CASTING OVER BOTTOM OF COLORBAND JOINT TRIM AND SECURE WITH EIGHT #8-32 x 3/4 SMS.
- FRONT PANEL TRIM "B" & "C" LOWER TRIM "B" MUST BE INSTALLED FIRST. LOCATE IT AND FASTEN WITH TWO #8 x 5/8 SMS. PLACE UPPER TRIM "C" IN PLACE AND INSTALL FOUR #8 x 5/8 SMS.
- REAR BAFFLE JOINT TRIM "G" POSITION TRIM AND FASTEN WITH FOUR #8 x 5/8 SMS.
- JOINT DRIP CHANNEL "I" THE JOINT DRIP CHANNEL SEALS THE GAP CREATED BY THE JOINTING OF THE TWO END FRAMES. CENTER THE CHANNEL AND SLIP OVER THE FRAME.
- KICKPLATE JOINT TRIM "D" POSITION AND FASTEN WITH TWO #10-16 x 1/2 SMS.
- CANOPY JOINT TRIM "E" HOOK LOWER EDGE OF CANOPY JOINT TRIM INTO PLACE & PUSH TO THE REAR. FASTEN WITH FOUR #8 x 3/4 SMS.
- ROOM AIR FAN PLENUM TRIM "F" POSITION AND INSTALL WITH FOUR #8 x 5/8 SMS.

*Accessory Part

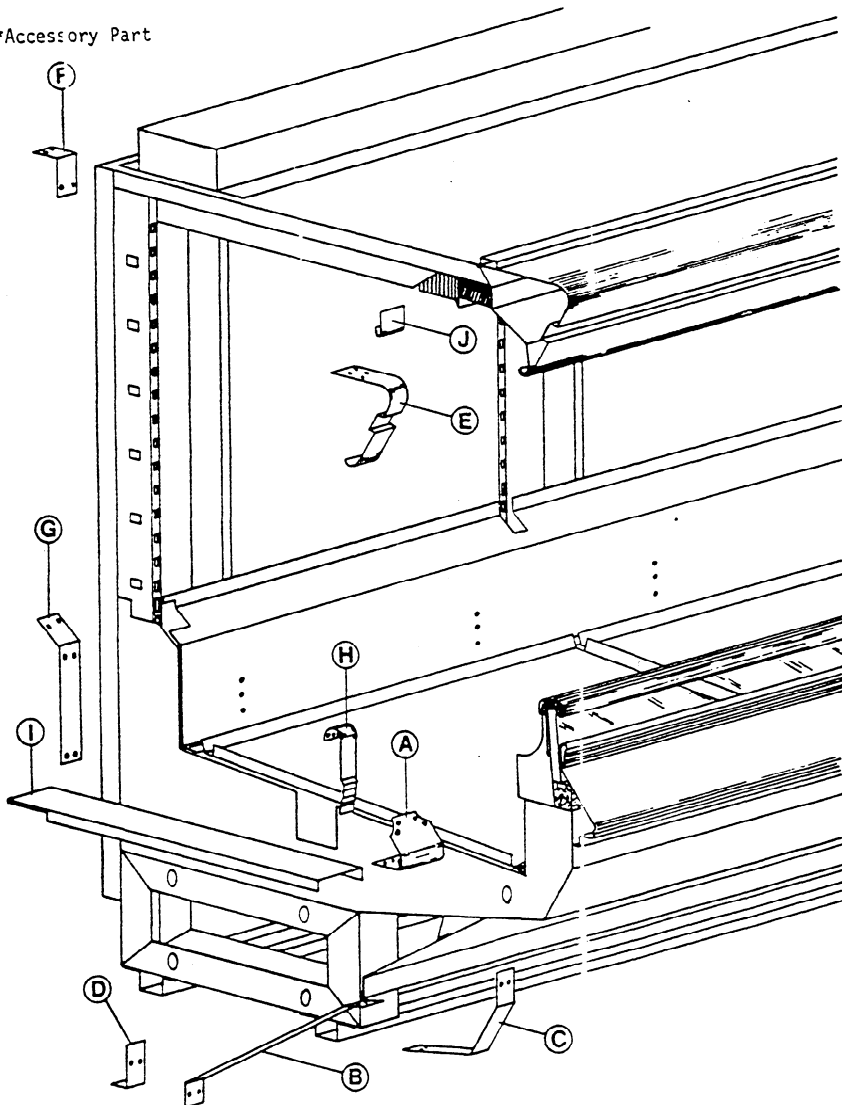

BACK TOP ANTISWEAT HEATERS
 MIA(G) 8' 81011-23 (.45Amps)
 MIA(G) 12' 81011-24 (.6Amps)

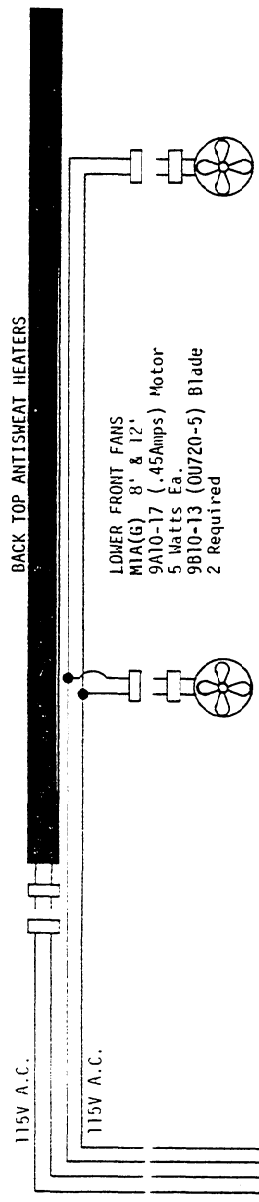

LOWER FRONT FANS
 MIA(G) 8' & 12'
 9A10-17 (.45Amps) Motor
 5 Watts Ea.
 9B10-13 (00720-5) Blade
 2 Required

THERMOPANE ANTISWEAT HEATER
 MIA8' 81A12-50 (.21Amps)
 MIA8' 81A12-34 (.4Amps)
 MIA12' 81A14-49 (.29Amps)
 MIA12' 81A14-34 (.4RAmps)



AIR DEFROST BLOWERS
 MIA(G) 8' 28012-12 (Blower) 2.9Amps
 MIA(G) 12' 28012-12 (Blower) 1Required

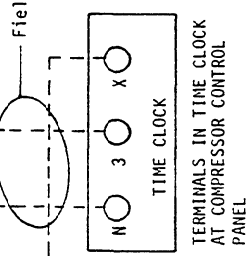
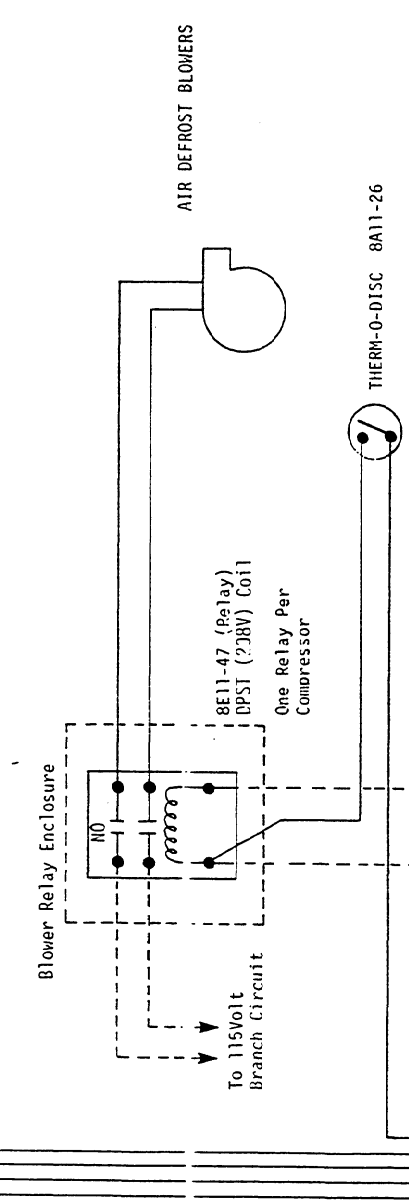

TITLE
 CASE WIRING DIAGRAM
 MIA (G) 8 & 12'

LETTER
DATE 3-29-55
SCALE NONE
DRAWN TIM ADAMS
APP'D. B. SMITH

REVISED
DATE BY

DRAWING NUMBER
 PB-20721
 WARRIOR ENGINEER
 DIVISION OF KYSOR INDUSTRIAL CORPORATION
 P. O. Box 1538, Atlanta, Georgia 30301

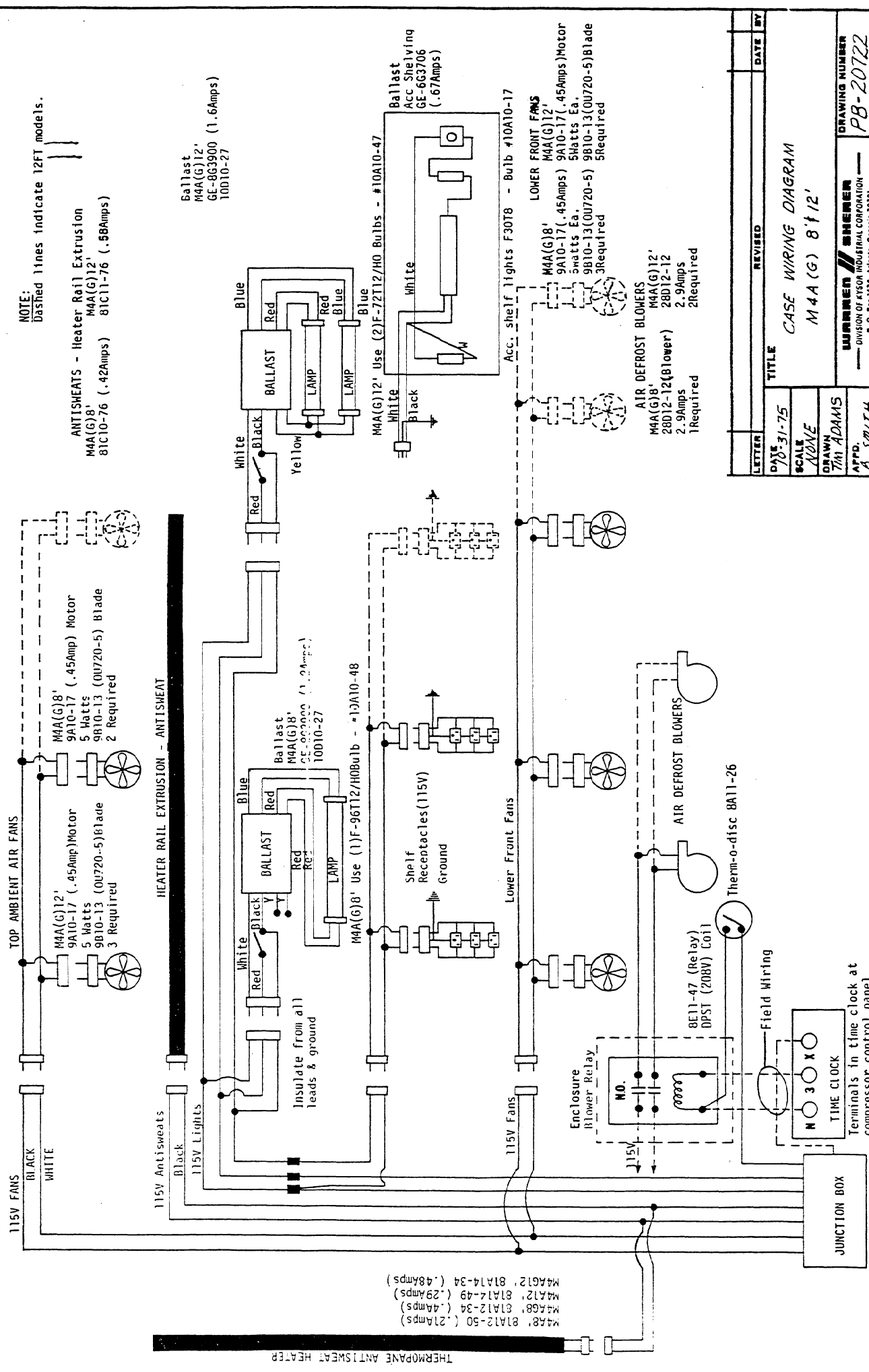

LETTER	REVISION	DATE	BY
		78-31-75	

SCALE	TITLE
AS SHOWN	CASE WIRING DIAGRAM
DRAWN	M4A(G) 8' 12'
THOMAS ADAMS	
APP'D.	
B. SMITH	

DRAWING NUMBER	PB-20722
LUBRIMET / SHEMEX DIVISION OF KYSOR INDUSTRIAL CORPORATION P. O. Box 1438, Allentown, Pa. 18101	

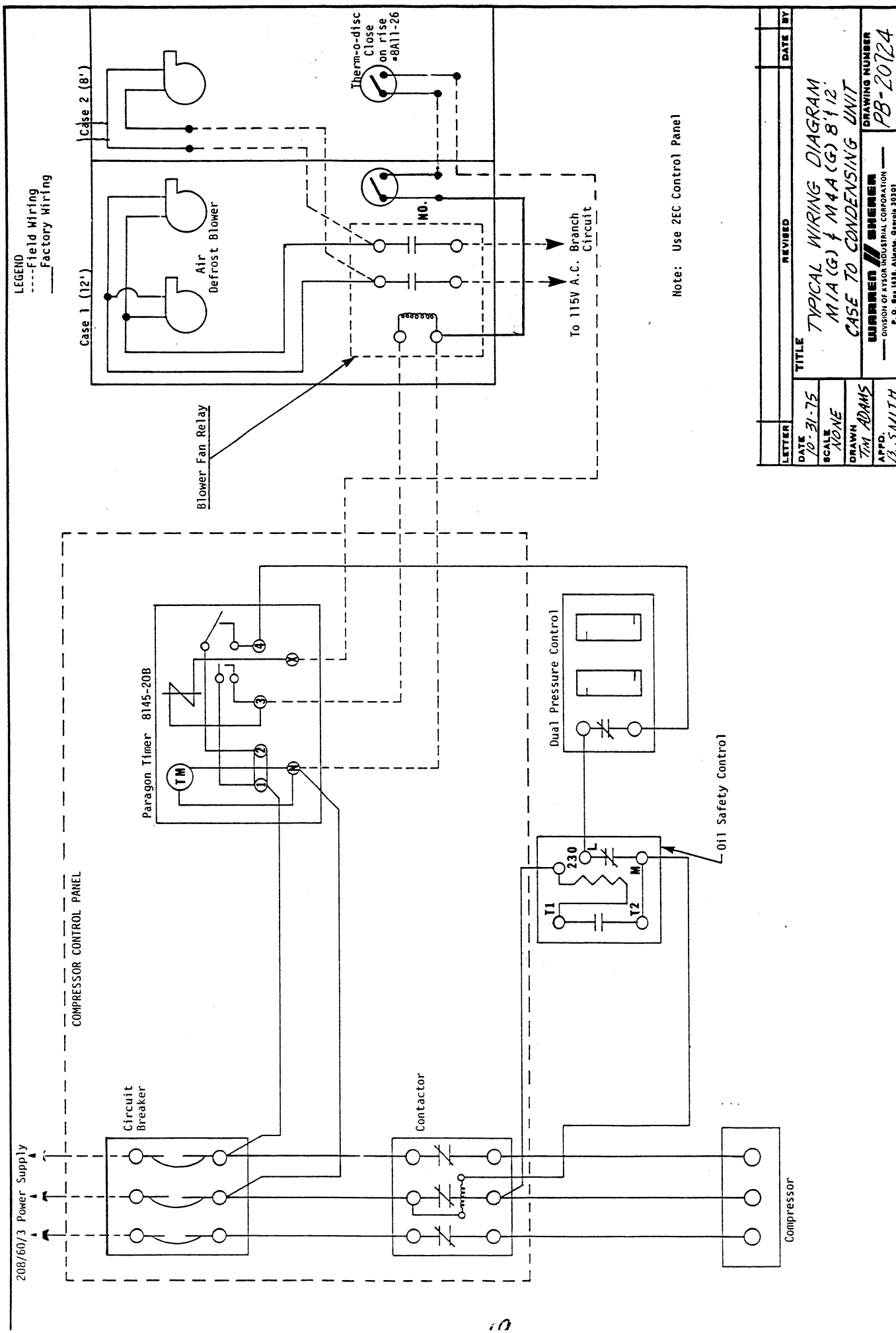

LETTER	REVISION	DATE	BY
TITLE TYPICAL WIRING DIAGRAM M1A (G) + M4A (G) 8' + 12' CASE TO CONDENSING UNIT			
DATE 10-31-75			
SCALE NONE			
DRAWN TIM ADAMS			
APP'D. B. SMITH			
DRAWING NUMBER PB-20724			
WARRIEN SINGER DIVISION OF LYON INDUSTRIAL CORPORATION P. O. BOX 1028, ALBUQUERQUE, NEW MEXICO 87101			

CASES	8 1/2 FT	CONDENSING UNIT SIZING R-12				CONDENSING UNIT SIZING R-502				DEFROST FANS		115 VOLTS 1 PHASE		
		75° STORE	SAH -AMBIENT-	SWH	0-75'	75-150'	SAH -AMBIENT-	SWH	0-75'	75-150'	115/114I RE AMPS	115/114I RE AMPS	FANCA/S AMPS	WILLITE/1 RE AMPS
1	018	3000	70	70	7/8	3/8	7/8	7/8	7/8	7/8	7/8	2.9	14	0.014
2	112	4000	70	70	7/8	3/8	7/8	7/8	7/8	7/8	7/8	2.9	14	0.014
2	016	6000	100	100	13/8	13/8	17/8	17/8	17/8	17/8	17/8	5.8	14	0.014
1	120	7400	150	150	150	150	150	150	150	150	150	5.8	14	0.014
0	124	8800	150	150	150	150	150	150	150	150	150	5.8	14	0.014
2	128	10400	200	200	200	200	200	200	200	200	200	5.8	14	0.014
1	232	11800	200	200	200	200	200	200	200	200	200	5.8	14	0.014
0	336	13200	200	200	200	200	200	200	200	200	200	5.8	14	0.014
2	140	14800	300	300	300	300	300	300	300	300	300	5.8	14	0.014
1	344	16200	300	300	300	300	300	300	300	300	300	5.8	14	0.014
0	448	17600	300	300	300	300	300	300	300	300	300	5.8	14	0.014
2	352	19200	300	300	300	300	300	300	300	300	300	5.8	14	0.014
1	456	20600	500	500	500	500	500	500	500	500	500	5.8	14	0.014
0	560	22000	500	500	500	500	500	500	500	500	500	5.8	14	0.014
2	454	23600	500	500	500	500	500	500	500	500	500	5.8	14	0.014
1	568	25000	500	500	500	500	500	500	500	500	500	5.8	14	0.014
0	672	26400	500	500	500	500	500	500	500	500	500	5.8	14	0.014
2	576	28000	500	500	500	500	500	500	500	500	500	5.8	14	0.014
1	680	29400	550	550	550	550	550	550	550	550	550	5.8	14	0.014
0	784	30800	550	550	550	550	550	550	550	550	550	5.8	14	0.014
2	688	32400	750	750	750	750	750	750	750	750	750	5.8	14	0.014
1	792	33800	750	750	750	750	750	750	750	750	750	5.8	14	0.014

AIR DEFROST

NOTES:

- COND. UNIT RECOMMENDATIONS BASED ON 75° F & 55% RH STORE AMBIENT. SAH(CAIR COOLED) UNIT SELECTION IS BASED ON AIR TEMPERATURE ENTERING CONDENSOR AS SHOWN. SWH (WATER COOLED) UNIT SELECTION BASED ON 2 GPM TON-75° F WATER ENTERING.
- COND. UNIT SUFFIX IS:
RL-LOW TEMP R-502
RC-MED TEMP R-502
FC-MED TEMP R-12
- CAUTION: THESE RECOMMENDATIONS BASED ON BEST INFORMATION AVAILABLE AND ON CONDITIONS AS LISTED FOR APPLICATIONS NOT LISTED CONSULT ENGINEERING DEPARTMENT. LINE LENGTHS SHOWN ARE EQUIVALENT LENGTHS. TO DETERMINE EQUIVALENT LENGTH MEASURE ACTUAL LINEAL LENGTH FROM COMPRESSOR TO FURTHEST CASE AND ADD FOUR FEET FOR EACH ELBOW OR OTHER FITTING.
- CAUTION: THESE RECOMMENDATIONS BASED ON BEST INFORMATION AVAILABLE AND ON CONDITIONS AS LISTED FOR APPLICATIONS NOT LISTED CONSULT ENGINEERING DEPARTMENT. LINE LENGTHS SHOWN ARE EQUIVALENT LENGTHS. TO DETERMINE EQUIVALENT LENGTH MEASURE ACTUAL LINEAL LENGTH FROM COMPRESSOR TO FURTHEST CASE AND ADD FOUR FEET FOR EACH ELBOW OR OTHER FITTING.
- CAUTION: THESE RECOMMENDATIONS BASED ON BEST INFORMATION AVAILABLE AND ON CONDITIONS AS LISTED FOR APPLICATIONS NOT LISTED CONSULT ENGINEERING DEPARTMENT. LINE LENGTHS SHOWN ARE EQUIVALENT LENGTHS. TO DETERMINE EQUIVALENT LENGTH MEASURE ACTUAL LINEAL LENGTH FROM COMPRESSOR TO FURTHEST CASE AND ADD FOUR FEET FOR EACH ELBOW OR OTHER FITTING.
- RISER AND P-TRAPS SHOULD BE REDUCED ONE SIZE FROM THAT SHOWN. WIRE SIZES ARE BASED ON 100' OF TYPE T AND TM.
- LIGHTS: STANDARD WITH ONE 20" DS LIGHTED SHELF. ADD .7 AMPS & 250 BTUH EA. ADDT'L 4" SHELF
- ONE 230 VOLT A.C. RELAY REQUIRED AT CASE LINE-UP PER COMPRESSOR CONTROLS 115V. DEFROST FANS.
- WASTE OUTLET IS STD. 1 1/2" F.P.T.

M1A

MD-7511-01 CONNECTIONS: SUCTION LINE 5/8 OD, LIQUID LINE 3/8 OD FRESH MEAT
W A R R E N / S H E R R CONDENSING UNIT RECOMMENDATIONS , REFRIGERANT LINE SIZING , ELECTRICAL DATA FOR : MODEL M1A UP TO 75 ° STORE , SUCTION TEMPERATURE 10°

CASES	BTUH	CONDENSING UNIT SIZING R-12				CONDENSING UNIT SIZING R-502				DEFROST FANS		115 VOLTS 1 PHASE	
		75°	75°	75°	75°	75°	75°	75°	75°	115/114	115/114	FANS/WIRE	FANS/WIRE
12 FT	12 FT	SAH	SWH	0-75'	75-150'	SAH	SWH	0-75'	75-150'	AMPS	IRE	AMPS	IRE
12 FT	12 FT	90°	95°	L	S	90°	95°	L	S				
1	3000	70	70	7/8	3/8	7/8	7/8					2.9	1/4
0	4400	70	70	7/8	3/8	7/8	7/8					2.0	1/4
2	6000	100	100	13/8	3/8	17/8	17/8					5.8	1/4
1	7400	150	150	13/8	3/8	17/8	17/8					3.8	1/4
0	8800	150	150	13/8	3/8	17/8	17/8					4.0	1/4
2	10400	200	200	13/8	3/8	17/8	17/8					5.6	1/4
1	11800	200	200	13/8	3/8	17/8	17/8					5.8	1/4
0	13200	300	300	13/8	3/8	17/8	17/8					5.9	1/4
2	14800	300	300	13/8	3/8	17/8	17/8					7.6	1/4
1	16200	300	300	13/8	3/8	17/8	17/8					7.7	1/4
0	17600	300	300	13/8	3/8	17/8	17/8					7.9	1/4
2	19200	500	500	13/8	3/8	17/8	17/8					9.5	1/4
1	20600	500	500	13/8	3/8	17/8	17/8					9.7	1/4
0	22000	500	500	13/8	3/8	17/8	17/8					9.9	1/4
2	23600	500	500	13/8	3/8	17/8	17/8					11.5	1/4
1	25000	500	500	13/8	3/8	17/8	17/8					11.7	1/4
0	26400	500	500	13/8	3/8	17/8	17/8					11.9	1/4
2	28000	500	500	13/8	3/8	17/8	17/8					13.5	1/4
1	29400	550	550	13/8	3/8	17/8	17/8					13.7	1/4
0	30800	550	550	13/8	3/8	17/8	17/8					13.9	1/4
2	32400	750	750	13/8	3/8	17/8	17/8					15.5	1/2
1	33800	750	750	13/8	3/8	17/8	17/8					15.7	1/2

AIR DEFROST

NOTES:

- COND. UNIT RECOMMENDATIONS BASED ON 75° F & 55% RH STORE AMBIENT.
- SAH(AIR COOLED) UNIT SELECTION IS BASED ON AIR TEMPERATURE ENTERING CONDENSOR AS SHOWN, SWH (WATER COOLED) UNIT SELECTION BASED ON 2 GPM 70N-75° F WATER ENTERING.
- COND. UNIT SUFFIX IS:
RL-Low Temp R-502
RC-Med Temp R-502
FC-Med Temp R-12
- CAUTION: THESE RECOMMENDATIONS BASED ON BEST INFORMATION AVAILABLE AND ON CONDITIONS AS LISTED FOR APPLICATIONS NOT LISTED CONSULT ENGINEERING DEPARTMENT.
LINE LENGTHS SHOWN ARE EQUIVALENT LENGTHS. TO DETERMINE EQUIVALENT LENGTH MEASURE ACTUAL LINEAL LENGTH FROM COMPRESSOR TO FURTHEST CASE AND ADD FOUR FEET FOR EACH ELBOW OR OTHER FITTING.
- RISER AND P-TRAPS SHOULD BE REDUCED ONE SIZE FROM THAT SHOWN OF TYPE T AND TW.
- LIGHTS: STANDARD WITH ONE 20" DS BTUH EA. ADD 1/4" SHELF
- ONE 230 VOLT A.C. RELAY REQUIRED AT CASE LINE-UP PER COMPRESSOR CONTROLS 115V. DEFROST FANS.
- WASTE OUTLET IS STD. 1 1/2" F.P.T.

M1AG

CONNECTIONS: SUCTION LINE 5/8 OD, LIQUID LINE 3/8 OD

MD-7511-02

W A R R E N / S H E R R CONDENSING UNIT RECOMMENDATIONS, REFRIGERANT LINE SIZING, ELECTRICAL DATA FOR: MODEL M1AG UP TO 75° STORE SUCTION TEMPERATURE 10°

FRESH MEAT

CASES	CONDENSING UNIT SIZING R-12				CONDENSING UNIT SIZING R-502				DEFROST FANS				115 VOLTS 1 PHASE							
	STORE RTU#	SAH SWH	90° 95°	75° 75°	75-150' L S L	75-150' L S L	SAH SWH	90° 95°	75° 75°	0-75' L S L	75-150' L S L	115V/1 AMPS	115V/1 WI RE	FAN#/S AMPS	WI RE	LI TE WI RE				
1	08	11100	200	200	150	378	1-1/8	1/2	1-1/8	1/2	7/8	1/2	1-1/8	1/2	1-1/8	1/2	3.1	14	2.6	14
2	0116	22200	300	500	300	1/2	1-1/8	1/2	1-1/8	1/2	1-1/8	1/2	1-1/8	1/2	1-1/8	1/2	4.6	14	3.6	14
1	120	27600	500	500	500	1/2	1-3/8	5/8	1-3/8	5/8	1-3/8	5/8	1-3/8	5/8	1-3/8	5/8	6.1	14	5.1	14
0	2124	33000	550	550	570	5/8	1-3/8	5/8	1-3/8	5/8	1-3/8	5/8	1-3/8	5/8	1-3/8	5/8	7.7	14	6.1	14
2	120	38700	750	750	750	5/8	1-5/8	5/8	1-5/8	5/8	1-5/8	5/8	1-5/8	5/8	1-5/8	5/8	9.3	14	7.2	14
1	2132	44100	750	750	750	5/8	1-5/8	5/8	1-5/8	5/8	1-5/8	5/8	1-5/8	5/8	1-5/8	5/8	10.8	14	8.7	14
0	3136	49500	780	780	750	5/8	1-5/8	5/8	1-5/8	5/8	1-5/8	5/8	1-5/8	5/8	1-5/8	5/8	12.4	14	9.8	14
2	2140	55200	780	1000	780	7/8	1-5/8	7/8	1-5/8	7/8	1-5/8	7/8	1-5/8	7/8	1-5/8	7/8	13.9	14	10.8	14
1	3144	60600	1000	1000	1000	7/8	1-5/8	7/8	1-5/8	7/8	1-5/8	7/8	1-5/8	7/8	1-5/8	7/8	15.4	14	12.1	14
0	4148	66000	1500	1500	1000	7/8	1-5/8	7/8	1-5/8	7/8	1-5/8	7/8	1-5/8	7/8	1-5/8	7/8	17.0	14	13.3	14
2	3152	71700	1500	1500	1500	7/8	1-5/8	7/8	1-5/8	7/8	1-5/8	7/8	1-5/8	7/8	1-5/8	7/8	18.6	14	14.4	14
1	4156	77100	1500	1500	1500	7/8	1-5/8	7/8	1-5/8	7/8	1-5/8	7/8	1-5/8	7/8	1-5/8	7/8	20.1	14	15.9	14
0	5160	82500	2000	2000	1500	7/8	1-5/8	7/8	1-5/8	7/8	1-5/8	7/8	1-5/8	7/8	1-5/8	7/8	21.7	14	17.0	14
2	4164	88200	2000	2000	2000	7/8	1-5/8	7/8	1-5/8	7/8	1-5/8	7/8	1-5/8	7/8	1-5/8	7/8	23.2	14	18.1	14
1	5168	93600	2000	2000	2000	7/8	1-5/8	7/8	1-5/8	7/8	1-5/8	7/8	1-5/8	7/8	1-5/8	7/8	24.7	14	19.5	14
0	6172	99000	2000	2500	2000	7/8	1-5/8	7/8	1-5/8	7/8	1-5/8	7/8	1-5/8	7/8	1-5/8	7/8	26.3	14	20.6	14
2	5176	104700	2500	2500	2000	7/8	1-5/8	7/8	1-5/8	7/8	1-5/8	7/8	1-5/8	7/8	1-5/8	7/8	27.9	14	21.7	14
1	6180	110100	2500	2500	2500	7/8	1-5/8	7/8	1-5/8	7/8	1-5/8	7/8	1-5/8	7/8	1-5/8	7/8	29.4	14	23.1	14
0	7184	115500	2500	2500	2500	7/8	1-5/8	7/8	1-5/8	7/8	1-5/8	7/8	1-5/8	7/8	1-5/8	7/8	31.0	14	24.2	14
2	6188	121200	2500	0	2500	7/8	1-5/8	7/8	1-5/8	7/8	1-5/8	7/8	1-5/8	7/8	1-5/8	7/8	32.5	14	25.3	14
1	7192	126600	0	0	2500	7/8	1-5/8	7/8	1-5/8	7/8	1-5/8	7/8	1-5/8	7/8	1-5/8	7/8	34.0	14	26.7	14

AIR DEFROST

NOTES:

- COND. UNIT RECOMMENDATIONS BASED ON 75° F & 55% RH STORE AMBIENT.
- SAH(AIR COOLED) UNIT SELECTION IS BASED ON AIR TEMPERATURE ENTERING CONDENSOR AS SHOWN. SWH (WATER COOLED) UNIT SELECTION BASED ON 2 GPM TON-75° F WATER ENTERING.
- COND. UNIT SUFFIX IS:
RU-LOW TEMP R-502
RC-MED TEMP R-502
FC-MED TEMP R-12
- CAUTION: THESE RECOMMENDATIONS BASED ON BEST INFORMATION AVAILABLE AND ON CONDITIONS AS LISTED FOR APPLICATIONS NOT LISTED CONSULT ENGINEERING DEPARTMENT.
LINE LENGTHS SHOWN ARE EQUIVALENT LENGTHS, TO DETERMINE EQUIVALENT LENGTH MEASURE ACTUAL LINEAL LENGTH FROM COMPRESSOR TO FURTHEST CASE AND ADD FOUR FEET FOR EACH ELBOW OR OTHER FITTING.
- RISER AND P-TRAPS SHOULD BE REDUCED ONE SIZE FROM THAT SHOWN. WIRE SIZES ARE BASED ON 100' OF TYPE T AND TM.
- LIGHTS: STANDARD WITH ONE 20" DS LIGHTED SHELF. ADD .7 AMPS & 250 BTUH EA. ADD 1" 4" SHELF
- ONE 230 VOLT A.C. RELAY REQUIRED AT CASE LINE-UP PER COMPRESSOR CONTROLS 115V. DEFROST FANS.
- WASTE OUTLET IS STD. 1 1/2" F.P.T.

M 4 A G

MD-7511-06 CONNECTIONS: SUCTION LINE 7/8 OD, LIQUID LINE 3/8 OD FRESH MEAT
V A R R E N / S H E R R CONDENSING UNIT RECOMMENDATIONS, REFRIGERANT LINE SIZING, ELECTRICAL DATA FOR: MODEL M4AG
UP TO 75° STORE

CASES	75° STORE RTU/D	CONDENSING UNIT SIZING R-12				CONDENSING UNIT SIZING R-502				DEFROST FANS				115 VOLTS 1 PHASE	
		SAH -AMBIENT- 90°	SWH 75°	L	S	SAH -AMBIENT- 90°	SWH 75°	L	S	115V/1W/1 AMPS	RE	RE	RE	FANCA/S AMPS	W/11TE/1W/1 RE/AMPS/RE
1	10100	150	150	3/8	7/8	1-1/8	1/2	1-1/8	1/2	7/8	1/2	7/8	1-1/8	2.9	14
0	1112	15100	200	200	1/2	1-1/8	1/2	1-1/8	1/2	7/8	1/2	1-1/8	5.8	14	3.6
2	0116	20200	300	300	1/2	1-1/8	1/2	1-1/8	1/2	1-1/8	5/8	1-1/8	5.8	14	5.0
1	1120	25200	300	500	1/2	1-3/8	5/8	1-3/8	5/8	1-1/8	5/8	1-3/8	7.4	14	6.1
0	2124	30200	500	500	5/8	1-3/8	5/8	1-3/8	5/8	1-3/8	5/8	1-3/8	9.0	14	7.2
2	1128	35300	500	550	5/8	1-3/8	5/8	1-3/8	5/8	1-3/8	5/8	1-3/8	10.3	14	8.6
1	2132	40300	550	550	5/8	1-3/8	5/8	1-3/8	5/8	1-3/8	5/8	1-3/8	11.9	14	9.7
0	3136	45300	750	750	5/8	1-5/8	7/8	1-5/8	7/8	1-5/8	7/8	1-5/8	13.5	14	10.8
2	2140	50400	750	780	5/8	1-5/8	7/8	1-5/8	7/8	1-5/8	7/8	1-5/8	14.8	14	11.2
1	3144	55400	780	780	7/8	1-5/8	7/8	1-5/8	7/8	1-5/8	7/8	1-5/8	16.4	12	13.3
0	4148	60400	780	1000	7/8	1-5/8	7/8	1-5/8	7/8	1-5/8	7/8	1-5/8	18.0	12	14.4
2	3152	65500	1000	1000	7/8	1-5/8	7/8	1-5/8	7/8	1-5/8	7/8	1-5/8	19.3	12	15.8
1	4156	70500	1000	1000	7/8	1-5/8	7/8	1-5/8	7/8	1-5/8	7/8	1-5/8	20.9	10	16.9
0	5160	75500	1500	1500	7/8	2-1/8	7/8	2-1/8	7/8	2-1/8	7/8	2-1/8	22.5	10	18.0
2	4164	80600	1500	1500	7/8	2-1/8	7/8	2-1/8	7/8	2-1/8	7/8	2-1/8	23.8	10	19.4
1	5168	85600	1500	1500	7/8	2-1/8	7/8	2-1/8	7/8	2-1/8	7/8	2-1/8	25.4	10	20.5
0	6172	90600	2000	2000	7/8	2-1/8	7/8	2-1/8	7/8	2-1/8	7/8	2-1/8	27.0	10	21.6
2	5176	95700	2000	2000	7/8	2-1/8	7/8	2-1/8	7/8	2-1/8	7/8	2-1/8	28.3	10	23.0
1	6180	100700	2000	2000	7/8	2-1/8	7/8	2-1/8	7/8	2-1/8	7/8	2-1/8	29.9	10	24.1
0	7184	105700	2000	2000	7/8	2-1/8	7/8	2-1/8	7/8	2-1/8	7/8	2-1/8	31.5	8	25.2
2	6188	110800	2500	2500	7/8	2-1/8	7/8	2-1/8	7/8	2-1/8	7/8	2-1/8	32.8	8	26.6
1	7192	115800	2500	2500	7/8	2-1/8	7/8	2-1/8	7/8	2-1/8	7/8	2-1/8	34.4	8	27.7

AIR DEFROST

NOTES:

- COND. UNIT RECOMMENDATIONS BASED ON 75° F & 55% RH STORE AMBIENT.
- SAH(CAIR COOLED) UNIT SELECTION IS BASED ON AIR TEMPERATURE ENTERING CONDENSOR AS SHOWN. SWH (WATER COOLED) UNIT SELECTION BASED ON 2 GPM TON-75° F WATER ENTERING.
- COND. UNIT SUFFIX IS:
 PL-LOW TEMP R-502
 RC-MED TEMP R-502
 FC-MED TEMP R-12
- CAUTION: THESE RECOMMENDATIONS BASED ON BEST INFORMATION AVAILABLE AND ON CONDITIONS AS LISTED FOR APPLICATIONS NOT LISTED CONSULT ENGINEERING DEPARTMENT.
 LINE LENGTHS SHOWN ARE EQUIVALENT LENGTHS. TO DETERMINE EQUIVALENT LENGTH MEASURE ACTUAL LINEAL LENGTH FROM COMPRESSOR TO FURTHEST CASE AND ADD FOUR FEET FOR EACH ELBOW OR OTHER FITTING.
- RISER AND P-TRAPS SHOULD BE REDUCED ONE SIZE FROM THAT SHOWN. WIRE SIZES ARE BASED ON 100' OF TYPE T AND TV.
- LIGHTS: STANDARD WITH ONE 20" DS BTUH EA. ADDT'L 4' SHELF ONE 230 VOLT A.C. RELAY REQUIRED AT CASE LINE-UP PER COMPRESSOR CONTROLS 115V. DEFROST FANS. WASTE OUTLET IS STD. 1 1/2" F.P.T.

M 4 A

MD-7511-03 CONNECTIONS: SUCTION LINE 7/8 OD, LIQUID LINE 3/8 OD DELI MEAT
 V A R R E N / S H E R R CONDENSING UNIT RECOMMENDATIONS, REFRIGERANT LINE SIZING, ELECTRICAL DATA FOR: MODEL M4A
 UP TO 75 ° STORE ; SUCTION TEMPERATURE 20°

CASES	75° STORE BTUH	CONDENSING UNIT SIZING R-12				CONDENSING UNIT SIZING R-502				DEFROST FANS		115 VOLTS 1 PHASE			
		SAH	SWH	0-75°	75-150°	SAH	SWH	0-75°	75-150°	115/110V	FANCA/S	WILLITE/1	AMPS	RE	
1	8	150	150	7/8	1/2	210	210	7/8	1/2	1-1/8	5.8	11	4.6	14	3.6
1	12	15100	200	200	1/2	210	210	7/8	1/2	1-1/8	5.8	11	4.6	14	3.6
2	1	20200	300	300	1/2	310	310	1-1/8	1/2	1-1/8	5.8	11	6.1	14	5.1
1	1	25200	300	300	1/2	310	310	1-1/8	1/2	1-1/8	5.8	11	7.7	14	6.1
0	2	30200	500	500	5/8	410	410	1-3/8	5/8	1-3/8	11.6	14	9.3	14	7.2
2	1	35300	500	500	5/8	510	510	1-3/8	5/8	1-3/8	11.6	14	10.8	14	8.7
1	2	40300	550	550	5/8	560	560	1-3/8	5/8	1-3/8	14.5	14	12.4	14	9.8
0	3	45300	750	750	5/8	560	560	1-3/8	5/8	1-3/8	17.4	14	13.9	14	10.8
2	2	50400	750	780	5/8	760	760	1-5/8	7/8	1-5/8	17.4	14	15.4	12	12.3
1	3	55400	780	780	5/8	760	760	1-5/8	7/8	1-5/8	20.3	14	17.0	12	13.4
0	4	60400	780	1000	7/8	790	790	1-5/8	7/8	1-5/8	23.2	14	18.6	12	14.4
2	3	65500	1000	1000	7/8	790	790	1-5/8	7/8	1-5/8	23.2	14	20.1	10	15.9
1	4	70500	1000	1000	7/8	1010	1010	1-5/8	7/8	1-5/8	26.1	14	21.7	10	17.0
0	5	75500	1500	1500	7/8	1010	1010	1-5/8	7/8	1-5/8	29.0	14	23.2	10	18.0
2	4	80600	1500	1500	7/8	1010	1010	1-5/8	7/8	1-5/8	29.0	14	24.7	10	19.5
1	5	85600	1500	1500	7/8	1010	1010	1-5/8	7/8	1-5/8	31.9	8	26.3	10	20.6
0	6	90600	2000	2000	7/8	1510	1510	1-1/8	7/8	1-1/8	34.8	8	27.9	10	21.7
2	5	95700	2000	2000	7/8	1510	1510	1-1/8	7/8	1-1/8	34.8	8	29.4	10	23.1
1	6	100700	2000	2000	7/8	1510	1510	1-1/8	7/8	1-1/8	37.7	8	31.0	8	24.2
0	7	105700	2000	2000	7/8	1510	1510	1-1/8	7/8	1-1/8	40.6	6	32.5	8	25.3
2	6	110800	2000	2500	7/8	2010	2010	1-1/8	7/8	1-1/8	40.6	6	34.0	8	26.7
1	7	115800	2500	2500	7/8	2010	2010	1-1/8	7/8	1-1/8	43.5	6	35.6	8	27.8

AIR DEFROST

NOTES:

- COND. UNIT RECOMMENDATIONS BASED ON 75° F & 55% RH STORE AMBIENT. SAH(CAIR COOLED) UNIT SELECTION IS BASED ON AIR TEMPERATURE ENTERING CONDENSOP AS SHOWN. SWH (WATER COOLED UNIT SELECTION BASED ON 2 GPM TON-75° F WATER ENTERING.
- COND. UNIT SUFFIX IS:
RL-LOW TEMP R-502
RC-MED TEMP R-502
FC-MED TEMP R-12

- CAUTION: THESE RECOMMENDATIONS BASED ON BEST INFORMATION AVAILABLE AND ON CONDITIONS AS LISTED FOR APPLICATIONS NOT LISTED CONSULT ENGINEERING DEPARTMENT.
- LINE LENGTHS SHOWN ARE EQUIVALENT LENGTHS. TO DETERMINE EQUIVALENT LENGTH MEASURE ACTUAL LINEAL LENGTH FROM COMPRESSOR TO FURTHEST CASE AND ADD FOUR FEET FOR EACH ELBOW OR OTHER FITTING.

- RISER AND P-TRAPS SHOULD BE REDUCED ONE SIZE FROM THAT SHOWN
- WIPE SIZES ARE BASED ON 100' OF TYPE T AND TW.
- LIGHTS: STANDARD WITH ONE 20" DS LIGHTED SHELF. ADD .7 AMPS & 250 BTUH EA. ADDT'L 4" SHELF
- ONE 230 VOLT A.C. RELAY REQUIRED AT CASE LINE-UP PER COMPRESSOR CONTROLS 115V. DEFROST FANS.
- WASTE OUTLET IS STD. 1 1/2" F.P.T.

MD-7511-04

CONNECTIONS:

SUCTION LINE 7/8 OD, LIQUID LINE 3/8 OD

M 4 AG

DELI MEAT

V A R R E N / S H E R R CONDENSING UNIT RECOMMENDATIONS , REFRIGERANT LINE SIZING , ELECTRICAL DATA FOR : MODEL M4AG UP TO 75 ° STORE

CASES	75° IBTUH FT REQ'D	CONDENSING UNIT SIZING R-12			CONDENSING UNIT SIZING R-502			DEFROST FANS			115 VOLTS 1 PHASE			
		SAH -AMBIENT- 90° 75°	SWH 0-75°	75-150'	SAH -AMBIENT- 90° 75°	SWH 0-75°	75-150'	115/114 AMPS	RE	115/114 AMPS	RE	FANEA/S AMPS	WI LITE	WI RE
1	108	3300												
2	112	4000												
2	016	6600												
1	120	8200												
0	224	9800												
2	128	11500												
1	232	13100												
0	336	14700												
2	240	16400												
1	344	18000												
0	448	19600												
2	352	21300												
1	456	22900												
0	560	24500												
2	464	26200												
1	568	27800												
0	672	29400												
2	576	31100												
1	680	32700												
0	784	34300												
2	688	36000												
1	792	37600												

AIR DEFROST

NOTES:

- COND. UNIT RECOMMENDATIONS BASED ON 75° F & 55% RH STORE AMBIENT.
- SAH(CAIR COOLED) UNIT SELECTION IS BASED ON AIR TEMPERATURE ENTERING CONDENSOR AS SHOWN. SWH (WATER COOLED) UNIT SELECTION BASED ON 2 GPH TON-75° F WATER ENTERING.
- COND. UNIT SUFFIX IS:
RL-LOW TEMP R-502
RC-MED TEMP R-502
FC-MED TEMP R-12
- CAUTION: THESE RECOMMENDATIONS BASED ON BEST INFORMATION AVAILABLE AND ON CONDITIONS AS LISTED FOR APPLICATIONS NOT LISTED CONSULT ENGINEERING DEPARTMENT.
- LINE LENGTHS SHOWN ARE EQUIVALENT LENGTHS. TO DETERMINE EQUIVALENT LENGTH MEASURE ACTUAL LINEAL LENGTH FROM COMPRESSOR TO FURTHEST CASE AND ADD FOUR FEET FOR EACH ELBOW OR OTHER FITTING.
- RISER AND P-TRAPS SHOULD BE REDUCED ONE SIZE FROM THAT SHOWN
- WIRE SIZES ARE BASED ON 100' OF TYPE T AND TH.
- LIGHTS: STANDARD WITH ONE 20" DS LIGHTED SHELF. ADD .7 AMPS & 250 BTUH EA. ADDT'L 4" SHELF
- ONE 230 VOLT A.C. RELAY REQUIRED AT CASE LINE-UP PER COMPRESSOR CONTROLS 115V. DEFROST FANS.
- WASTE OUTLET IS STD. 1 1/2" F.P.T.

MD-7511-07 CONNECTIONS: SUCTION LINE 5/8 OD, LIQUID LINE 3/8 OD FROZEN MEAT

W A R R E N / S H E R R CONDENSING UNIT RECOMMENDATIONS , REFRIGRANT LINE SIZING , ELECTRICAL DATA FOR : MODEL LM1A UP TO 75 ° STORE

CASES	75° STORE BTUH	CONDENSING UNIT SIZING R-12				CONDENSING UNIT SIZING R-502				DEFROST FANS		115 VOLTS 1 PHASE						
		SAH	SWH	0-75°	75-150°	SAH	SWH	0-75°	75-150°	115/11W1	FANCS/RE	SWI/RE	LI/RE	WI/RE				
8	12 FT	90°	95°	75°	L	S	L	S	L	S	L	S	L	S	AMPS	AMPS	AMPS	AMPS
1	0	8	3300												3.0	14	0.0	14
0	1	12	4900												3.4	14	0.0	14
2	0	116	6600												6.0	14	0.0	14
1	1	20	8200												6.4	14	0.0	14
0	2	24	9800												6.8	14	0.0	14
2	1	28	11500												9.4	14	0.0	14
1	2	32	13100												9.8	14	0.0	14
0	3	36	14700												10.2	14	0.0	14
2	2	40	16400												12.8	14	0.0	14
1	3	44	18000												13.2	14	0.0	14
0	4	48	19600												13.6	14	0.0	14
2	3	52	21300												16.2	12	0.0	14
1	4	56	22900												16.6	12	0.0	14
0	5	60	24500												17.0	12	0.0	14
2	4	64	26200												19.6	12	0.0	14
1	5	68	27800												20.0	12	0.0	14
0	6	72	29400												20.4	10	0.0	14
2	5	76	31100												23.0	10	0.0	14
1	6	80	32700												23.4	10	0.0	14
0	7	84	34300												23.8	10	0.0	14
2	6	88	36000												26.4	10	0.0	14
1	7	92	37600												26.8	10	0.0	14

AIR DEFROST

NOTES:

- COND. UNIT RECOMMENDATIONS BASED ON 75° F & 55% RH STORE AMBIENT.
- SAH(CAIR COOLED) UNIT SELECTION IS BASED ON AIR TEMPERATURE ENTERING CONDENSOR AS SHOWN. SWH (WATER COOLED) UNIT SELECTION BASED ON 2 GPM TON-75° F WATER ENTERING.
- COND. UNIT SUFFIX IS:
RL-L/W TEMP R-502
RC-MED TEMP R-502
FC-MFD TEMP R-17
- CAUTION: THESE RECOMMENDATIONS BASED ON BEST INFORMATION AVAILABLE AND ON CONDITIONS AS LISTED FOR APPLICATIONS NOT LISTED CONSULT ENGINEERING DEPARTMENT.
5. LINE LENGTHS SHOWN ARE EQUIVALENT LENGTHS. TO DETERMINE EQUIVALENT LENGTH MEASURE ACTUAL LINEAL LENGTH FROM COMPRESSOR TO FURTHEST CASE AND ADD FOUR FEET FOR EACH ELBOW OR OTHER FITTING.
- RISER AND P-TRAPS SHOULD BE REDUCED ONE SIZE FROM THAT SHOWN
- WIRE SIZES ARE BASED ON 100' OF TYPE T AND TW.
- LIGHTS: STANDARD WITH ONE 20" DS BTUH EA. ADDT'L 4' SHELF LIGHTED SHELF. ADD .7 AMPS & 250 ONE 230 VOLT A.C. RELAY REQUIRED AT CASE LINE-UP PER COMPRESSOR CONTROLS 115V. DEFROST FANS.
- WASTE OUTLET IS STD. 1 1/2" F.P.T.

L M 1 A G

MD-7511-08 CONNECTIONS: SUCTION LINE 5/8 OD, LIQUID LINE 3/8 OD

FROZEN MEAT

W A R R E N / S H E R R CONDENSING UNIT RECOMMENDATIONS , REFRIGERANT LINE SIZING , ELECTRICAL DATA FOR : MODEL LM1AG UP TO 75 ° STORE