

KYSOR **//WARREN**

The Leading Edge Of Technology

INSTALLATION & OPERATION MANUAL

MODEL: M1A(G)1 M3AG1 M4A(G)1 M5A1

MEAT MERCHANDISERS

THIS REFRIGERATOR CONFORMS TO THE COMMERCIAL
REFRIGERATOR MANUFACTURERS ASSOCIATION HEALTH AND
SANITATION STANDARD.

KYSOR  **//WARREN**

DIVISION OF KYSOR INDUSTRIAL CORPORATION

1600 INDUSTRIAL BLVD., CONYERS, GEORGIA 30207 / 404-483-5600
5201 TRANSPORT BLVD., COLUMBUS, GEORGIA 31907

INSTALLATION AND OPERATING INSTRUCTIONS

FOR

M1A(G)1, M3AG1, M4A(G)1, M51

SELF-SERVICE MEAT CASES

APPLICATION:

The Kysor//Warren single and multi-shelf and self-service meat cases are designed to merchandise packaged fresh (red) meats and deli products. These cases should be installed and operated according to the instructions contained in the manual to insure proper performance. They are designed for display of products in an air-conditioned store where temperature and humidity are maintained at a maximum of 75 degree F dry bulb temperature, 55% relative humidity, and *minimum of 65 degree F, 35% relative humidity.

*Defrost times may be excessive if temperature and humidity drop below the minimum noted.

<u>MODEL</u>	<u>DESCRIPTION</u>
M1A1	Single Deck Meat, Air Defrost, Metal Front
M1AG1	Single Deck Meat, Air Defrost, Glass Front
M3AG1	Multi-Deck Low Profile Meat or Deli, Air Defrost, Glass Front, Usually two or three Adjustable Shelves
M4A1	Multi-Deck Meat or Deli, Air Defrost, Metal Front, Usually two or three Adjustable Shelves
M4AG1	Multi-Deck Meat or Deli, Air Defrost, Glass Front, Usually two or three Adjustable Shelves
M51	Multi-Deck Meat or Deli, Electric Defrost, Usually three or four Adjustable Shelves

GENERAL

These display refrigerators may be installed individually or in a continuous line-up consisting of several 8' and 12' sections by using a joint trim kit. A plexiglass divider kit must be used between cases operating on different refrigeration systems. Divider will be factory installed if specified on order.

SHIPPING DAMAGE

All equipment should be examined for shipping damage before and during unloading. If there is any damage, the carrier should be notified immediately and an inspection requested. The delivery receipt must be noted that the equipment was received damaged. If damage is of a concealed nature you must contact the carrier immediately or no later than three (3) days following delivery. A claim must be filed with the carrier by the consignee for all damages.

NOTE: ALL CLAIMS FOR SHORTAGES MUST BE MADE WITHIN 10 DAYS AFTER RECEIPT OF SHIPMENT.

LOCATION

This refrigerator must be located on a firmly based floor and leveled within plus or minus 1/16". Use shims provided to level your refrigerator.

JOINING

Two or more fixtures of like models can be joined together to form a continuous line-up. Instructions for joining fixtures are included in the joint kit. Before lining up refrigerator, inspect refrigeration lines, electrical connections and controls to insure refrigerators are in proper line-up and are in the proper sequence.

NOTE: THESE REFRIGERATORS ARE LINED UP AT THE FACTORY AND ARE NUMBERED. INSURE THEY ARE LINED UP IN THE FIELD IN THE SAME SEQUENCE NUMBER.

WASTE OUTLET

These cases are equipped with a 1-1/2" FPT waste outlet connection which terminates in the center of the refrigerator below the insulated bottom. A 1-1/2" PVC water seal trap is furnished for field installation.

INSTALLING DRIP PIPE

Improperly installed drip pipes can seriously effect the operation of this equipment and result in increased maintenance costs. Listed below are some general rules for drip pipe installation.

1. Use the external water seal provided with the equipment. Never double seal a line.
2. Never use a pipe smaller than the size pipe or water seal supplied with the equipment.
3. Always provide as much fall as possible in drip pipe. (1" fall for each 4' of drip pipe.)
4. Avoid long runs in drip pipe which make it impossible to provide maximum fall in pipe.
5. Provide a drip space between drip pipe and floor drain or sewer connection.
6. Do not allow drip pipe to come in contact with uninsulated suction lines, which will cause the condensation from your refrigerator to freeze.

CLEANING

To insure minimum maintenance cost, cabinet should be thoroughly emptied and washed out once a month. The exterior should be washed weekly. A mild soap and water solution is recommended for painted surfaces of the cabinet. Do not use cleaners containing abrasive materials which will scratch or dull finish. The waste outlet should be flushed with water following each cleaning.

CAUTION: BE SURE THAT REFRIGERATION AND ALL ELECTRICAL POWER IS OFF BEFORE WASHING YOUR REFRIGERATOR.

NOTE: Never introduce water into the fixture faster than the waste outlet can carry it away. Do not use steam or high pressure system to clean the case as seals may be broken, which will cause the case to leak.

When cleaning lighted shelves, wipe down with a wet sponge or cloth so that water does not enter the light rails. **DO NOT USE A HOSE OR SUBMERGE SHELVES IN WATER.**

LOADING

Merchandise should not be placed in the fixture until all controls have been adjusted and the refrigerator is at proper temperature.

At no time should the fixture be stocked beyond the load line or over the front top of adjustable shelves. In doing so, you will seriously affect the performance, which will result in higher product temperatures and increase operating costs.

ELECTRICAL

All field installed wiring must comply with the **NATIONAL ELECTRICAL CODE AND LOCAL CODES.**

ELECTRICAL RACEWAY

An electrical raceway is provided with each refrigerator for running your fan, anti-sweat heaters, and defrost circuits from case to case without using conduit. This applies, of course, when the front bumper is properly secured into position. This is an approved method by the Underwriters' Laboratories; however, wiring must be run in accordance with local and national electrical codes.

ELECTRICAL CONNECTIONS

All field connections are made in the electrical raceway.

Make sure that proper voltage is supplied to your refrigerator. Check refrigerator nameplate for fan and anti-sweat volts and defrost volts. If a canopy is furnished, use a separate fused circuit. **ALL REFRIGERATORS MUST BE GROUNDED.**

Fan motors must operate continuously and panel must be marked sufficiently to prevent the fan motors and anti-sweat heaters from being turned off accidentally. When refrigerators are multiplexed, add the total of these amperage values to determine wire size and circuit protection. Anti-condensate controllers can be used to control the anti-condensate heater.

On electric defrost models, the defrost heater amperages should be added together, and if their rating exceeds the defrost time clock or condensing unit breaker capacity, a defrost relay and circuit breaker must be employed and furnished by others. Make sure that proper wire size and branch circuit protection are employed for safe operation.

Chart #1 shows the electrical ratings for your refrigerator. This is the same information that appears on your refrigerator nameplate.

CASE LIGHTING (M3AG1) (M4A(G)1, M51)

Cases are standard with one row of high output lamps. Ballasts are located behind the canopy. If lighted shelves are supplied, ballasts for each shelf will be located behind the lower bumper assembly in the electrical raceway. See wiring diagram for layout.

REFRIGERATING FAN MOTORS

The fan motors employed are permanently oiled for the life of the motor and requires no periodic maintenance. They are wired according to the enclosed wiring diagram and **MUST RUN CONTINUOUSLY.**

ANTI-SWEAT HEATERS

These heaters are placed in the fixture to eliminate sweat forming on certain areas of fixture.

EXPANSION VALVE

The expansion valve furnished with your refrigerator has been sized for maximum coil efficiency. To adjust superheat, place a thermocouple under the expansion valve bulb. Read the suction line pressure as near coil as possible. (If at the condensing unit, estimate suction line loss at 2PSIG.) Convert coil suction pressure to temperature. The difference between coil temperature and the thermocouple temperature is superheat. (Use average superheat when expansion valve is hunting.) Do not set superheat until cases have pulled down to operating temperature and never open or close valve over 1/4 turn between adjustments and allow 10 minutes or more between adjustments. Superheat should be set to 6-8 degree F. To access the expansion valve, remove the left deck pan when facing the case.

REFRIGERATION LINES

The refrigeration lines are located under the deck pans on the 8' and 12' cases. A refrigeration outlet is provided in the front right hand end of the case. Make sure all refrigeration lines lie as close to the refrigerator bottom so as not to obstruct the air pattern or block the deck pans. See the section on "Recommended Piping Practices" for additional details on piping practices.

These 8' and 12' refrigerators have polyurethane foamed-in-place insulation. In opening a ferrule hole, simply heat a piece of copper tubing of the same size as the tubing to be employed and force it through the ferrule hole.

IMPORTANT: SEAL AROUND LINES AFTER CONNECTIONS ARE MADE. KEEP DIRECT FLAME FROM BOTTOM OF REFRIGERATOR, AS HEAT WILL DISINTEGRATE THE ALUMINUM BOTTOM AND INSULATION. USE A HEAT SHIELD WHEN WELDING NEAR THE BOTTOM OF THE CASES.

REFRIGERANT

Expansion valves are supplied for the refrigerant specified on the original sales order.

HEAT EXCHANGER

Heat exchangers are standard in these refrigerators. They aid to increase efficiency and reduce frosting and flood-back to compressor. Heat exchangers may not be used if mechanical sub-cooling is incorporated in the system design.

OPERATION

On a single condensing unit systems a thermostat should be used to control temperatures. The thermostat bulb should be mounted in the discharge air. On parallel units, temperature control can be provided by EPR valve, thermostat and liquid line *solenoid or solid state low pressure controls on compressor unit. Chart #2 shows approximate settings for merchandisers. Since many variables are present in each installation, such as store temperature, length of tubing runs, temperature desired in refrigerator, etc., Chart #2 is only a guide for the installer. *See Chart #2 note 2.

DEHYDRATION OF REFRIGERATION SYSTEMS

Please read carefully before placing system into operation. After laying refrigerant lines, they should be blown out before making final connection at fixture or condensing unit. Use dry nitrogen to prevent any foreign matter being left in the lines. Keep pressure below 250 pounds. To prevent scaling due to brazing, dry nitrogen should be allowed to flow through lines while brazing operations are taking place.

After the refrigeration system has been pressure-tested and proven leak-free, it is recommended that the system be dehydrated with a vacuum pump to 1000 microns for the first two evacuations and 500 microns on the third. The triple evacuation method requires evacuating the system three successive times and breaking the first two vacuums with dry nitrogen. The third vacuum would be broken with the refrigerant specified for the system.

CAUTION: DURING INSTALLATION AND SERVICE OF THIS EQUIPMENT, PRECAUTIONS SHOULD BE TAKEN TO PREVENT LOSS OF REFRIGERANT TO THE ATMOSPHERE.

DEFROST CYCLE

"AIR DEFROST" Models M1A(G)1, M3AG1, M4A(G)1 - On these model refrigerators, the evaporator fans run continuously; however, they reverse the air flow during defrost cycle. In defrost, the air is pulled into the case through the refrigeration discharge grill, through the ducts, coils, and discharged out the return air duct.

Defrost termination is by bi-metal "fixed" temperature control, wired in series and set to terminate at 45 degree F on the coil. See Chart #2 for defrost clock control settings. The defrost cycle is started by the time clock, which reverses the contacts on the relay normally installed at the case, causing the evaporator fan motors to reverse and reverse the air flow to defrost the coils.

NOTE: DO NOT USE PUMP DOWN SYSTEMS WITH AIR DEFROST. ON PARALLEL COMPRESSOR SYSTEMS, AN ELECTRIC STOP EPR VALVE OR SOLENOID IS REQUIRED IN THE SUCTION LINE.

"HOT GAS DEFROST" Models M1A(G)1, M3AG1, M4A(G)1, M51 - On hot gas defrost models, (optional for parallel compressor operation only) hot gas is routed through the suction line and evaporator coil. It exits the coil through a by-pass around the expansion valve and heat exchanger to return to the liquid line where the condensed liquid is used to feed the other cases on the same parallel unit. The case fans continue to operate during defrost to warm the drain pan and air ducts.

On M1AG1's, an adjustable termination control is used. The control is located at the left end of the case in the electrical raceway. Access to the adjustment dial is from under the electrical raceway. The control bulb is at the same end of the case in the discharge air stream above the coil.

On M4AG1's & M51's an adjustable defrost termination control is used also. The control is located at the left end of the case in the canopy light rail. The control bulb is at the same end of the case in the discharge air stream above the coil.

ELECTRIC DEFROST MODELS - M1A(G)1, M3AG1, M4A(G)1, M51

When the defrost timer initiates a defrost, the refrigeration stops, case fans continue to operate in the normal direction and defrost heaters are energized to clear the coil of frost and ice. When the coil temperature reaches 55 degrees F (as sensed by a Thermo Disc on a return bend at the left end of the coil) the defrost is terminated and the case returns to the refrigeration cycle.

NOTE: For safety purposes, all electric defrost cases have a thermal cut-off that de-energizes the heaters at temperatures over 70 degrees F. This safety Thermo Disc is located adjacent to the defrost terminator.

CHART #1

<u>MODEL</u>	<u>EVAPORATOR FANS (AMPS)</u>	<u>ANTI-COND HEATER (AMPS)</u>	<u>LIGHTS (AMPS)</u>	<u>DEFROST (AMPS)</u>
M1A1-4	.82	.43		3.3
M1A1-6	.82	.61		5.61
M1A1-8	.82	.70		7.93
M1A1-12	1.64	1.22		11.54
M1AG1-4	.82	.91		3.3
M1AG1-6	.82	1.11		5.61
M1AG1-8	.82	1.07		7.93
M1AG1-12	1.64	1.71		11.54
M3AG1-6	.37	1.03	.39	5.61
M3AG1-8	1.11	.89	.46	7.93
M3AG1-12	1.48	1.29	.74	11.54
M4A1-4	.82	.36	.80	3.3
M4A1-6	.82	.53	1.20	5.61
M4A1-8	2.46	.52	1.20	7.93
M4A1-12	3.28	.80	1.60	11.54
M4AG1-4	.82	.84	.80	3.3
M4AG1-6	.82	1.03	1.20	5.61
M4AG1-8	2.46	.89	1.20	7.93
M4AG1-12	3.28	1.29	1.60	11.54
M4AL1-8	2.46	.52	1.20	7.93
M4AL1-12	3.28	.80	1.60	11.54
M4ALG1-8	2.46	.89	1.20	7.93
M4ALG1-12	3.28	1.29	1.60	11.54

M51-8	2.46	.99	1.20	7.93
M51-12	3.28	1.32	1.60	11.54

For standard shelf light, add .64 amps per shelf.

For shelves with electric ballasts, add .25 for each shelf.

CHART #2

Recommended Control Settings

<u>MODEL</u>	<u>REFRIGERANT</u>	<u>EPR SETTING</u>	<u>THERMOSTAT</u>	
			<u>CUT-OUT</u>	<u>CUT-IN</u>
ALL M1/M3/M4 (+15DgF Evap)	HCFC-22	37#	22Dg	26Dg
	HFC-134a	15#		
	HFC-404a	49#		
	HFC-507	51#		
M5 (+10DgF Evap)	HCFC-22	33#	22Dg	26Dg
	HFC-134a	12#		
	HFC-404a	44#		
	HFC-507	45#		

<u>MODELS</u>	<u>DEFROST PERIODS FREQUENCY</u>	<u>TERMINATION (DEGREE-F) (4)</u>			<u>FAIL SAFE SETTING (MINUTES)</u>		
		<u>AIR</u>	<u>HOT GAS</u>	<u>ELEC</u>	<u>AIR</u>	<u>HOT GAS</u>	<u>ELEC</u>
M1A(G)1	3	45	50	55	45	18	30
M4AG1, M3AG1	4	45	50	55	45	18	30
M51	6	--	50	55	--	18	30

- NOTE: (1) A defrost termination control is installed on the coil of each case and must be wired in series with trip solenoid on the time clock.
- (2) DO NOT USE PUMP DOWN SYSTEMS WITH AIR DEFROST. On parallel compressor systems, an electric EPR valve on solenoid is required in the suction line.
- (3) Hot gas models use an adjustable defrost termination control. (M1A(G)1 M4A(G)1 M51)
- (4) Temperature is measured in discharge air.

M1A(G)1 & M4A(G)1
Parts List

<u>Description</u>	<u>M1A(G)1-8</u>	<u>M4A(G)1-8</u>	<u>M1A(G)1-12</u>	<u>M4A(G)1-12</u>	<u>Part No.</u>
Evap Fan Motor (9W Rev)	1	2	2	3	9A10-56
Evap Fan Blade (8", 20oP)	1		2		9B10-59
Evap Fan Blade (8", 30oP)		2		3	9B10-43
Expansion Valve BFRE-A-C	1	1	1		3A11-51
Expansion Valve BFRE-C-C				1	3A20-35
Defrost Control (Air Def)	1	1	1	1	8A11-26
Temp Cntrl (opt)					8A11-27
Defrost Relay (Air Def)	1	1	1	1	8E11-54
Defrost Control (Hot Gas)	1	1	1	1	8A11-27
Defrost Control (Elec)	1	1	1	1	8A11-49
Electric Defrost Safety	1	1	1	1	8A11-50
Honeycomb Grill (M4A(G)1)		2		3	13A15-29
Honeycomb Grill (M1A(G)1)	2		3		13A15-12
Anti-Sweat Heater (thermopane)	1	1	1	1	81D10-30 81D11-31
Back Rail Heater	1		1		10K12-62 10K12-63
Honeycomb Heater		1		1	81D10-33 81D11-32
Thermopane (Glass)	1	1	1	1	14D10-82 14D10-83
Thermopane Cap (Glass)	1	1	1	1	55D19-35 55D21-27
Front Baffle (Glass)	2	2	3	3	14B10-47
Lamps (Canopy) F40T12N		2		3	10A10-22
Ballast (Canopy) 2-Lamp		1		1	10D10-38
Ballast (Canopy) 1-Lamp				1	10D10-37
Lamp Holder-Red Wires				2	10B11-49
Lamp Holder-Blue Wires				2	10B11-50
Lamp Holder-Yellow Wires				2	10B11-51

Parts List Cont.

<u>Description</u>	<u>M1A(G)1-8</u>	<u>M4A(G)1-8</u>	<u>M1A(G)1-12</u>	<u>M4A(G)1-12</u>	<u>Part No.</u>
Lamp (Shelf ea.)					10A10-22
Starter (Shelf ea.)					10J12-11
Ballast (Shelf ea.)					10D10-12
External Drain Trap	1	1	1	1	60N11-48
Deck Pans	4	4	6	6	54N18-237
Adj Wire Rack	4	4	6	6	28G19-251
Canopy Joint Trim		1		1	55P18-302
Colorband Joint Trim	1	1	1	1	55P12-375
Glass Models	1	1	1	1	55P12-373
Front Panel Joint Trim	1	1	1	1	55P10-221
Glass Models	1	1	1	1	55P10-224
M4AL1					55P10-226
Upper Front Panel	1	1			51A12-222
Glass Model	1	1			51A12-224
Glass Model			1	1	51A14-173
Glass Model			1	1	51A14-175
Lower Front Panel	1	1			51A12-208
			1	1	51A14-160
Canopy Front Panel				1	51C14-68
		1			51C12-72
Kickplate (painted)			1	1	51A14-159
	1	1			51A12-207
Colorband Bright (Non Glass)	1	1	1	1	55F14-128
					55F12-150
Colorband Bright (Glass)	1	1	1	1	55F12-151
					55F14-129
Canopy/Colorband Insert (painted)	1	1	1	1	51A34-47
					51A34-48

Parts List Cont.

<u>Description</u>	<u>M51 -8</u>	<u>M51 -12</u>	<u>Part Number</u>
Lamp (Shelf ea.)			10A10-022
Starter (Shelf ea.)			10J12-011
Ballast (Shelf ea.)			10D10-012
External Drain Trap	1	1	60N11-048
Deck Pans	4	6	54N18-310
Adj. Wire Rack	4	6	28G19-251
Canopy Joint Trim	1	1	55P18-327
Colorband Joint Trim	1	1	55P12-375
Front Panel Joint Trim	1	1	55P10-222
Front Panel	1		51A12-221
		1	51A14-172
Canopy Front Panel		1	51C11-030
	1		51C11-031
Kickplate (Ptd)	1		51A12-297
		1	51A14-218
Colorband Bright	1		55F12-151
		1	55F14-128
Canopy/Colorband Insert (Ptd)	1		51A34-047
		1	51A34-048
Evap Fan Motor	3	4	09A10-041
Evap Fan Blade	3	4	09B10-055
Expansion Vlv BFRE-A-C	1		03A11-051
BFRE-B-C		1	03A12-039
Honeycomb Grill	2	3	13A15-029
Honeycomb Heater	1		10K12-062
		1	10K12-063

Parts List Cont.

<u>Description</u>	<u>M51 -8</u>	<u>M51 -12</u>	<u>Part Number</u>
Defrost Cntrl (Hot Gas)	1	1	08A11-027
Defrost Cntrl (Elec)	1	1	08A11-049
Electric Def Safety	1	1	08A11-050
Lamps (Canopy) F96T12N	1		10A10-048
Lamps (Canopy) F71T12N		2	10A10-047
Ballast (Cnpy) 1-Lamp	1	1	10A10-038
2-Lamp		1	10D10-036
Lamp Hldr-Red Wires Bi-Pin		2	10B11-049
Lamp Hldr-Blu Wires Bi-Pin		2	10B11-050
Lamp Hldr-Yel Wires Bi-Pin		2	10B11-051
Lamp Hldr-HO Male	1	2	10B11-019
Lamp Hldr-HO Female	1	2	10B11-020

JOINT KIT PARTS LIST

M1A1-M1A1

<u>Description</u>	<u>Quantity</u>	<u>Part Number</u>
Nut - 3/8 - 16 Hex SCP	4	19A15-010
Nut - 3/8 - Hex Head Tee	4	19A15-013
Washer - 3/8 Lock	4	19B13-010
Washer - 3/8 Cut	4	19B13-011
Washer - 3/8 Tee Nut	4	19B13-014
Bolt - 3/8 - 16 x 2	4	20E10-017
Sealant - Butyl White	1	29A10-029
Shim - PC "A"	8	54X17-023
Shim - PC "B"	8	54X17-024
Trim - Front Panel Brt	1	55P10-221
Screw - #8 x 1/2 PH SD Chrome	4	21B11-023
Trim - Colorband Joint Brt	1	55P12-375
Screw - #8 x 1/2 PH SD C	4	21B11-023
Trim - Top Cap Joint Brt	1	55P13-434
Screw - #8 x 1/2 PH SD Chrome	2	21B11-023

JOINT KIT PARTS LIST

M4A1-M4A1

<u>Description</u>	<u>Quantity</u>	<u>Part Number</u>
Nut - 3/8 - 16 Hex SCP	4	19A15-010
Nut - 3/8 - Hex Head Tee	4	19A15-013
Washer - 3/8 Lock	4	19B13-010
Washer - 3/8 Cut	4	19B13-011
Washer - 3/8 Tee Nut	4	19B13-014
Bolt - 3/8 - 16 x 2	2	20E10-017
Sealant - Butyl White	2	29A10-029
Shim - PC "A"	8	54X17-023
Shim - PC "B"	8	54X17-024
Trim - Front Panel Brt	1	55P10-221
Screw - #8 X 1/2 PH SD Chrome	4	21B11-023
Trim - Colorband Joint Brt	1	55P12-375
Screw - #8 x 1/2 PH SD Chrome	4	21B11-023
Trim - Canopy Front Brt	1	55P18-327
Screw - #8 - 16 x 1/2	2	21B12-031

JOINT KIT PARTS LIST

M51-M51

<u>Description</u>	<u>Quantity</u>	<u>Part Number</u>
Nut - 3/8 - 16 Hex SCP	4	19A15-010
Nut - 3/8 - Hex Head Tee	4	19A15-013
Washer - 3/8 Lock	4	19B13-010
Washer - 3/8 Cut	4	19B13-011
Washer - 3/8 Tee Nut	4	19B13-014
Bolt - 3/8 - 16 x 2	4	20E10-017
Sealant - Butyl White	2	29A10-029
Shim - PC "A"	8	54X17-023
Shim - PC "B"	8	54X17-024
Trim - Front Panel Brt	1	55P10-220
Screw - #8 x 1/2 PH SD Chrome	4	21B11-023
Trim - Colorband Joint Brt	1	55P12-375
Screw - #8 x 1/2 PH SD Chrome	4	21B11-023
Trim - Canopy Front Brt	1	55P18-327
Screw - #8 - 16 x 1/2	2	21B12-031

JOINT KIT PARTS LIST

M4AL1-M4AL1

<u>Description</u>	<u>Quantity</u>	<u>Part Number</u>
Nut - 3/8 - 16 Hex SCP	4	19A15-010
Nut - 3/8 - Hex Head Tee	4	19A15-013
Washer - 3/8 Lock	4	19B13-010
Washer - 3/8 Cut	4	19B13-011
Washer - 3/8 Tee Nut	4	19B13-014
Bolt - 3/8 - 16 x 2	4	20E10-017
Sealant - Butyl White	2	29A10-029
Shim - PC "A"	8	54X17-023
Shim - PC "B"	8	54X17-024
Trim - Front Panel Brt	1	55P10-224
Screw - #8 x 1/2 PH SD Chrome	4	21B11-023
Trim - Colorband Joint Brt	1	55P12-375
Screw - #8 x 1/2 PH SD Chrome	4	21B11-023
Trim - Canopy Front Brt	1	55P18-327
Screw - #8 - 16 x 1/2	2	21B12-031

RECOMMENDED PIPING PRACTICES FOR CASES

7/25/80
Revised 7/25/85

- ~1. Proper size refrigeration lines are essential to good refrigeration performance. Suction lines are more critical than liquid or discharge lines. Oversized suction lines may prevent proper oil return to the compressor. Undersized lines can rob refrigeration capacity and increase operating cost. Consult the technical manual or legend sheet for proper line sizes.
- ~2. Refrigeration lines in cases in line-ups can be reduced. However, the lines should be no smaller than the main trunk lines in at least 1/3 of the cases and no smaller than one size above the case lines to the last case. Reductions should not exceed one line size per case. It is preferred to bring the main trunk lines in at the center of line-up. Liquid lines on systems on hot gas defrost must be increased one line size above the main trunk line for the entire line-up. Individual feed lines should be at the bottom of the liquid header.
- ~3. Do not run refrigeration lines from one system through cases on another system.
- ~4. Use dry nitrogen in lines during the brazing to prevent scaling and oxidation.
- ~5. Insulate suction lines from the cases to the compressor with 3/4" wall thickness Armaflex or equal on low temperature cases to provide maximum of 65 Degree superheated gas back to the compressor and prevent condensation in exposed areas. Insulate suction lines on medium temperature cases with 1/2" thick insulation in exposed areas to prevent condensate droppage.
- ~6. Suction and liquid lines should never be taped or soldered together. Adequate heat exchanger is provided in the case.
- ~7. Refrigeration lines should never be placed in the ground unless they are protected against moisture and electrolysis attack.
- ~8. Always slope suction lines down toward the compressor, 1/2" each 10'. Do not leave dips in the line that would trap oil.
- ~9. Provide "P" traps at the bottom of suction line risers, 4' or longer. Use a double "P" trap for each 20' of risers. "P" traps should be the same size as the horizontal line. Consult the technical manual or legend sheet for proper size risers.
10. Use long radius ells and avoid 45 degree ells.

RECOMMENDED PIPING PRACTICES FOR CASES (continued)

11. Provide expansion loops in suction lines on systems on hot gas defrost. See Engineering Bulletin #85-204-3 for detail.
12. Strap and support tubing to prevent excessive line vibration and noise.
13. Brazing of copper to copper should be with a minimum of 10% silver. Copper to brass or copper to steel should be with 45% silver.
14. Avoid the use of "bull head" tees in suction lines. An example is where suction gas enters both ends of the tee and exits the center. This can cause a substantial increase in pressure drop in the suction lines.
15. When connecting more than one suction line to a main trunk line, connect each branch line with an inverted trap.

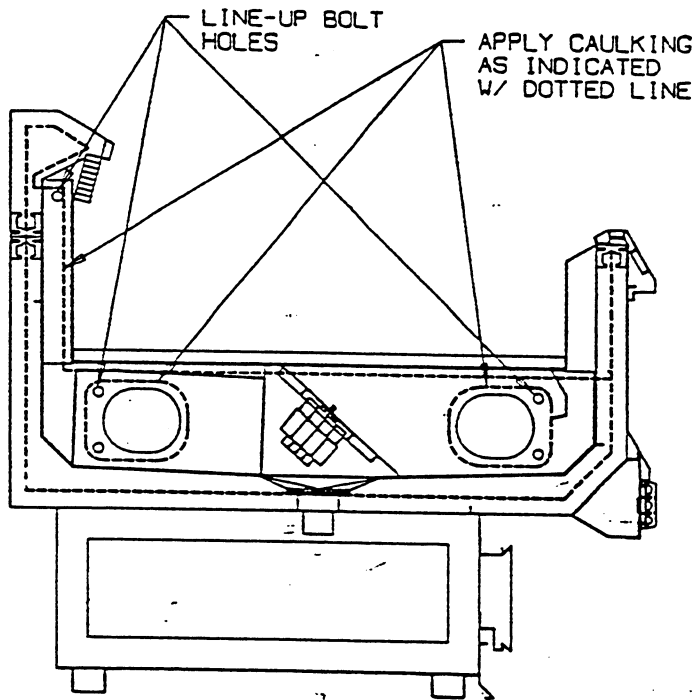

MI-1 CAULKING & LINE-UP BOLT
-DIAGRAM FOR JOINING CASES

CASE REAR

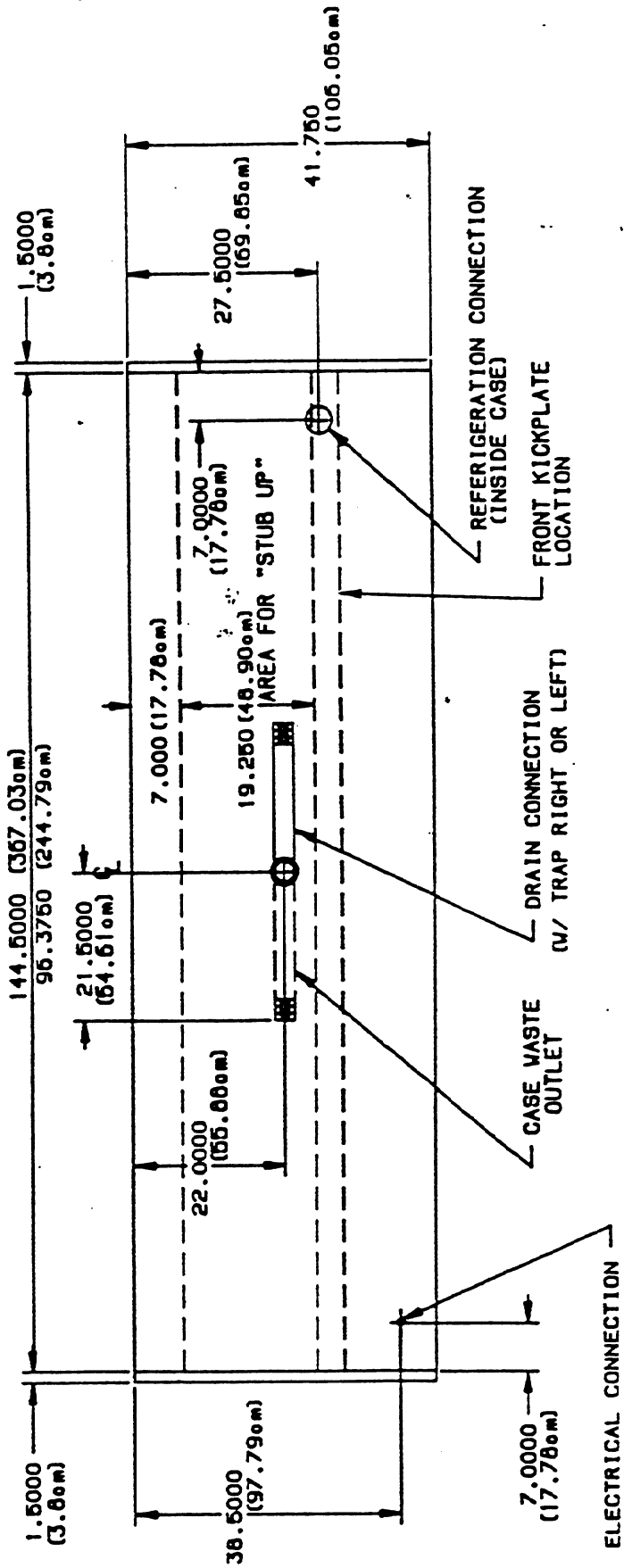

CASE FRONT

LETTER	REVISED	DATE	BY
TITLE			
PLAN VIEW - M1A1 8#12			
DATE	10/21/88		
SCALE	NONE		
DRAWN	B. BOOMBERG		
APPROVED	J.P.		
DRAWING NUMBER			FA-30066
WARREN / SHERER			DIVISION OF AVSOR INDUSTRIAL CORPORATION
KYSSOR			

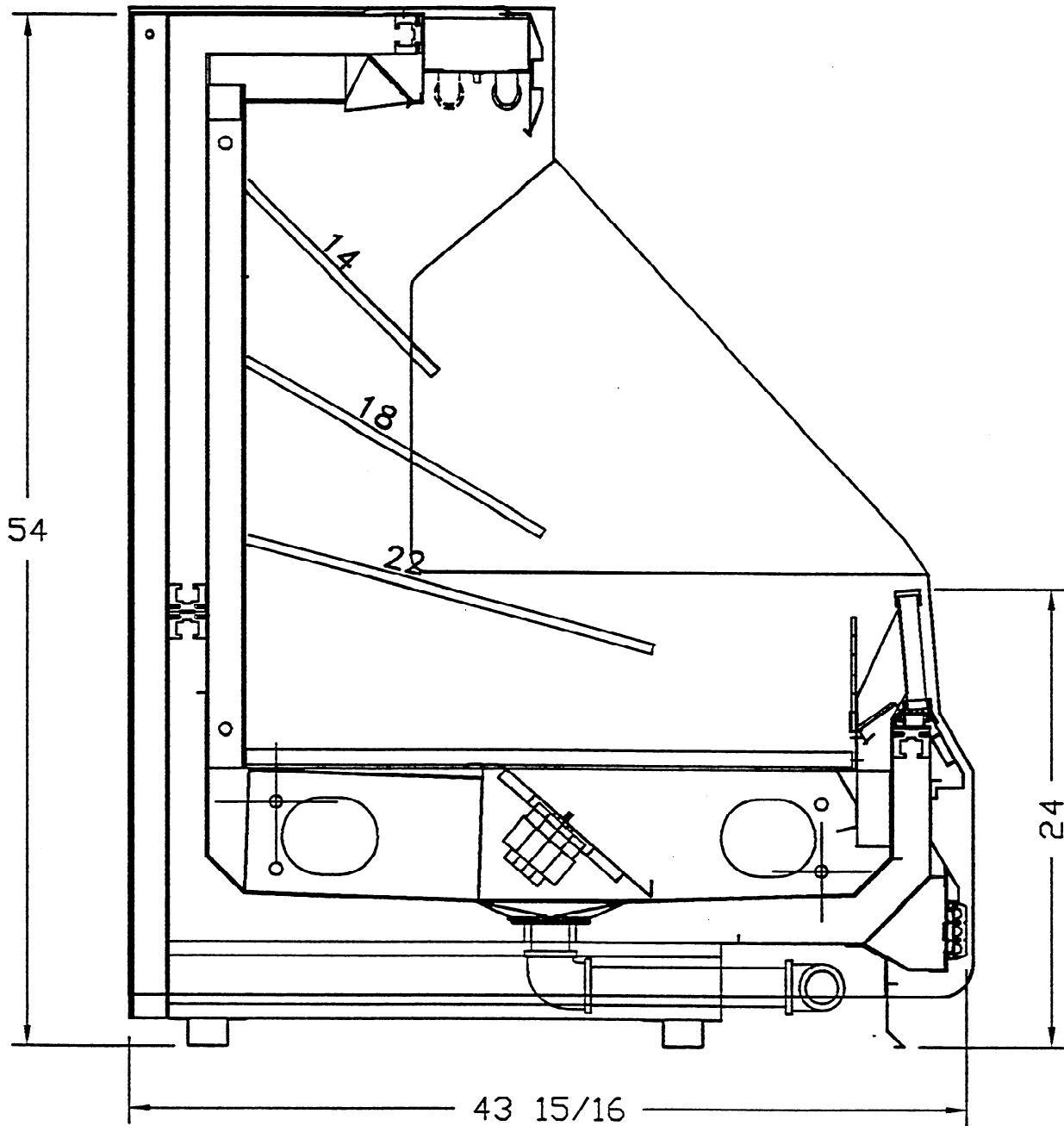

M3AG1

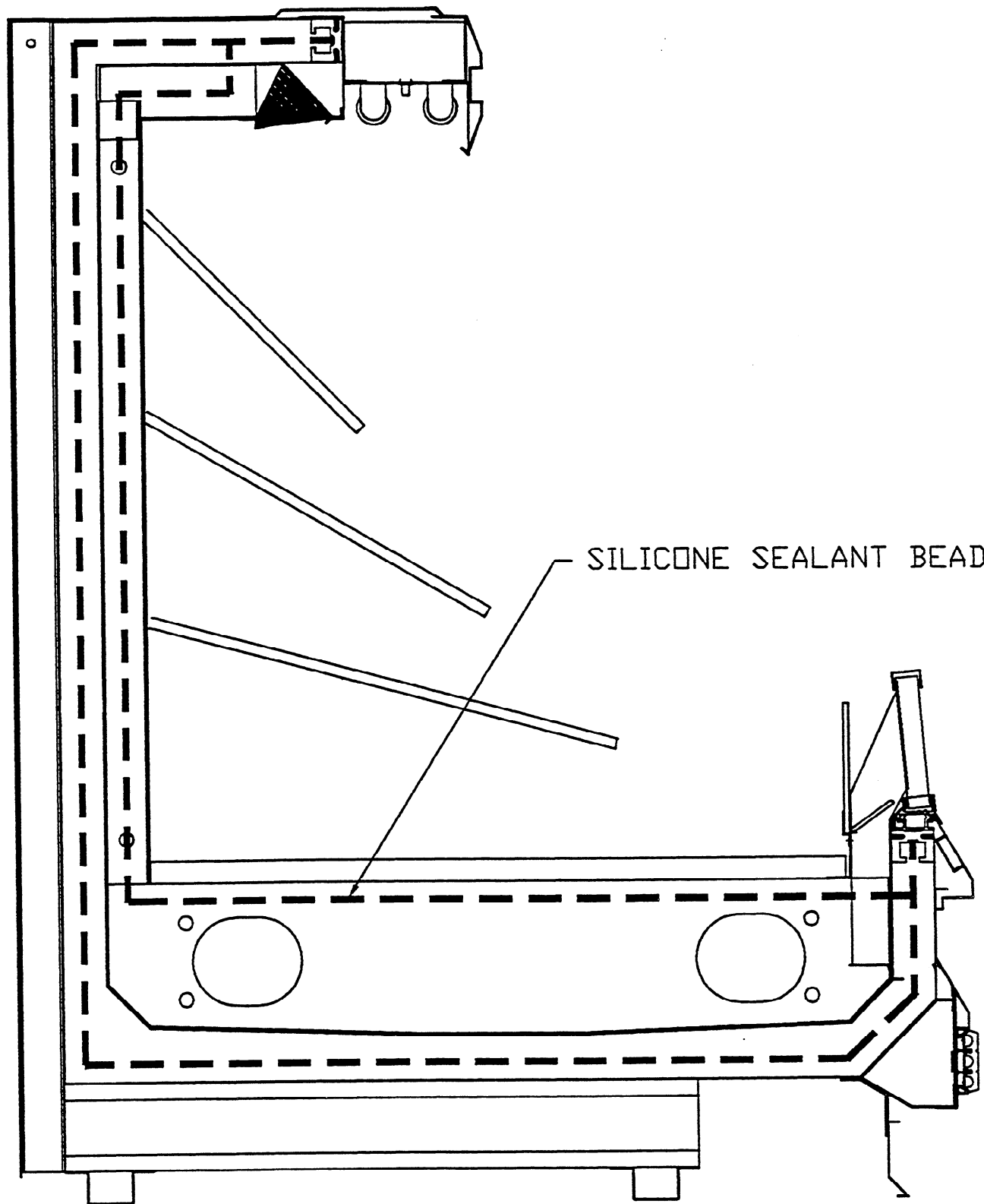

M3AG1

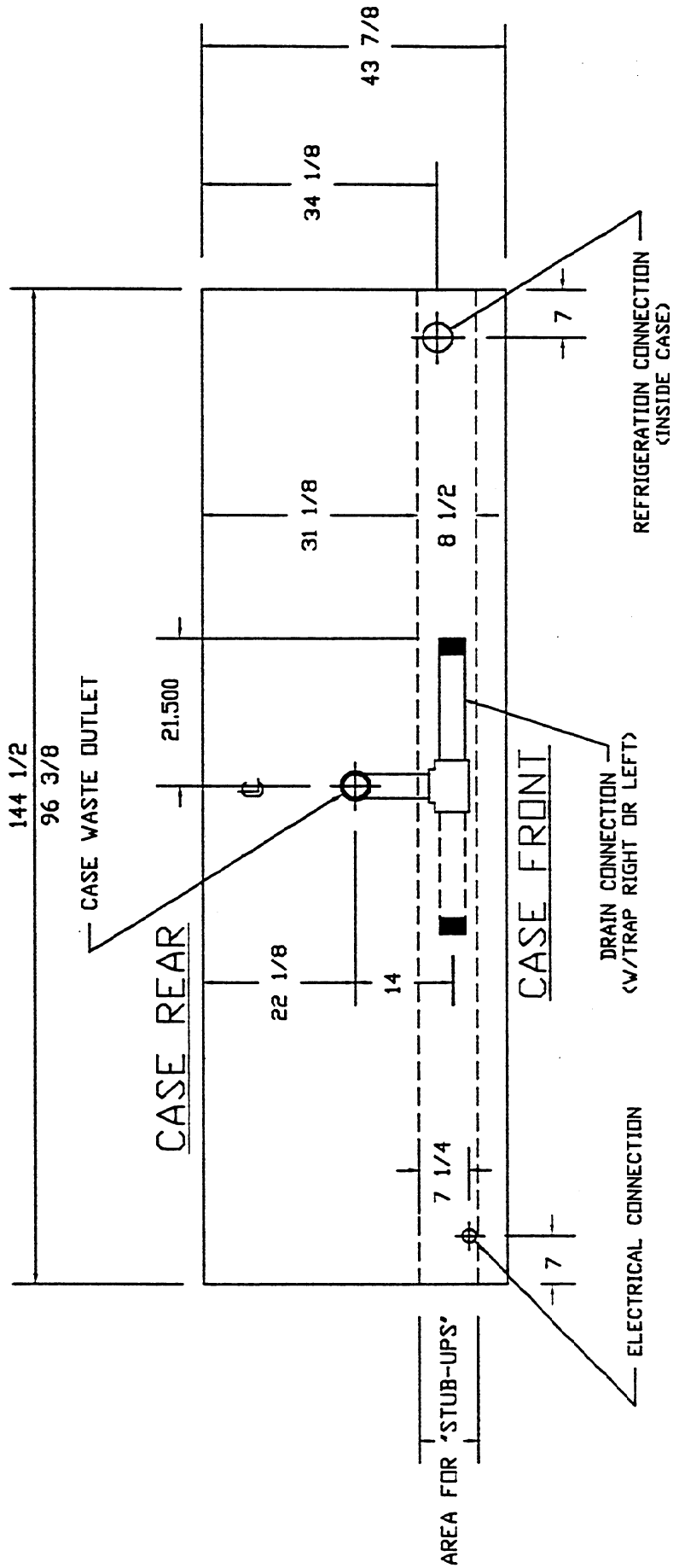

M3AG1

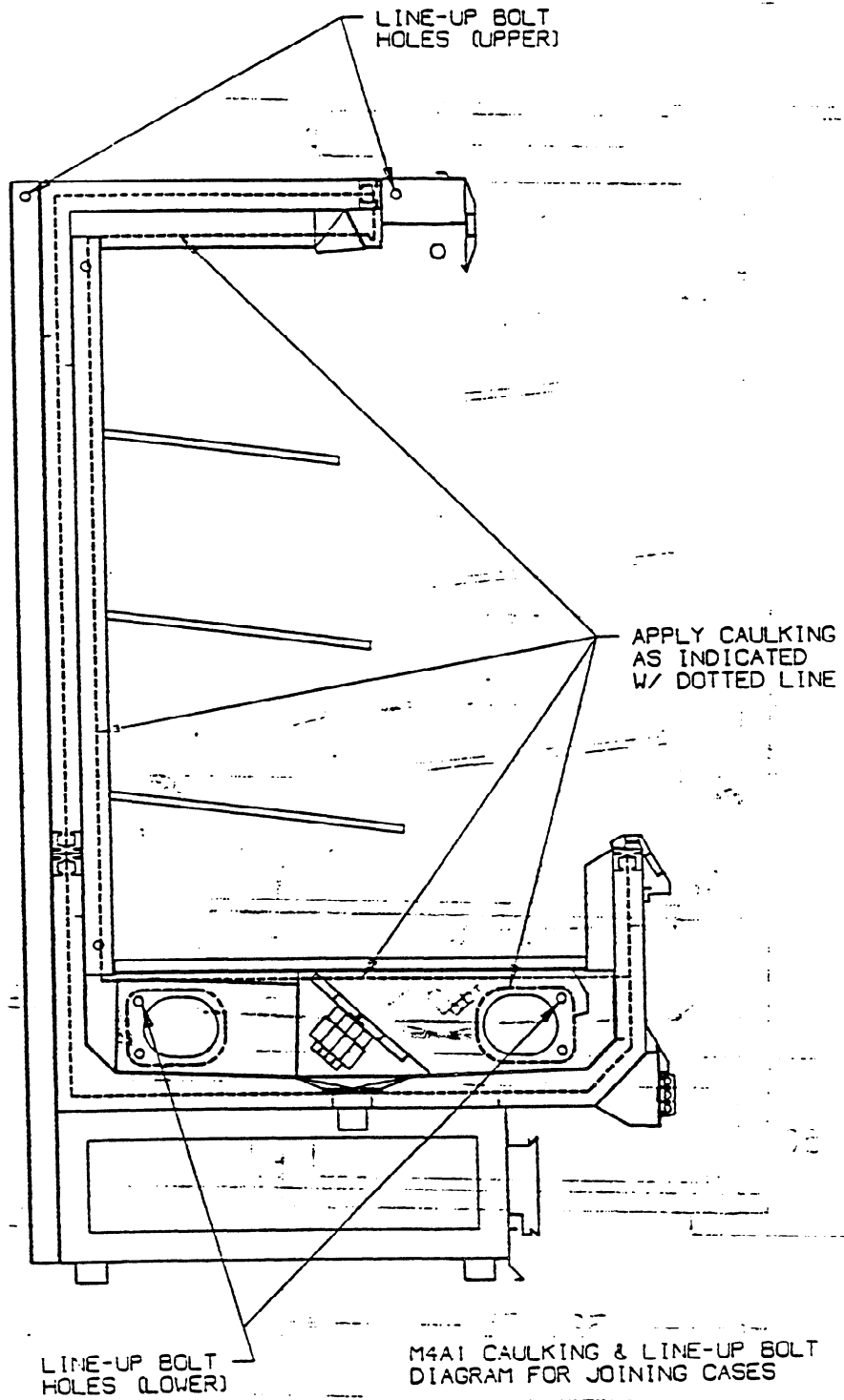

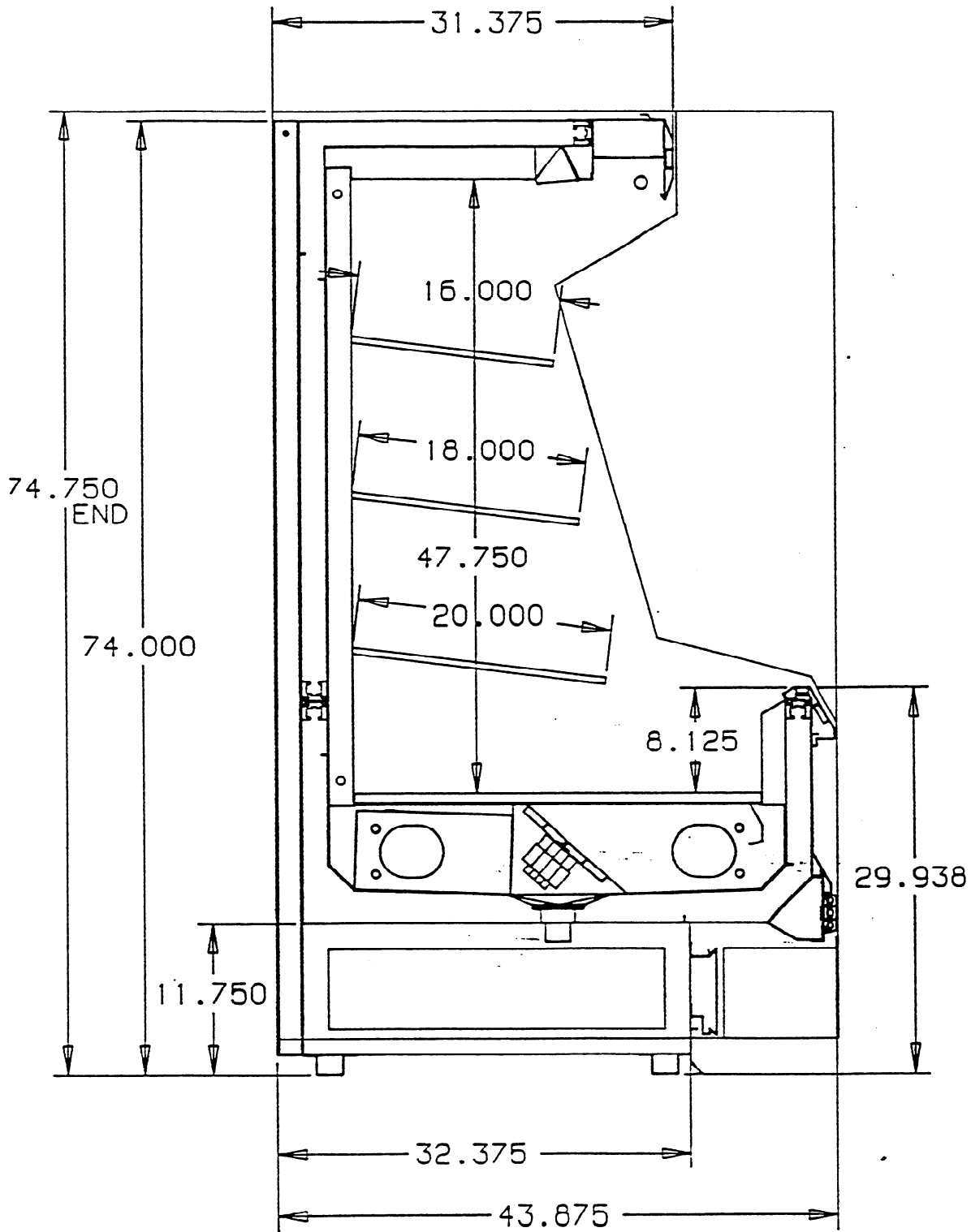

M4A1

CASE REAR

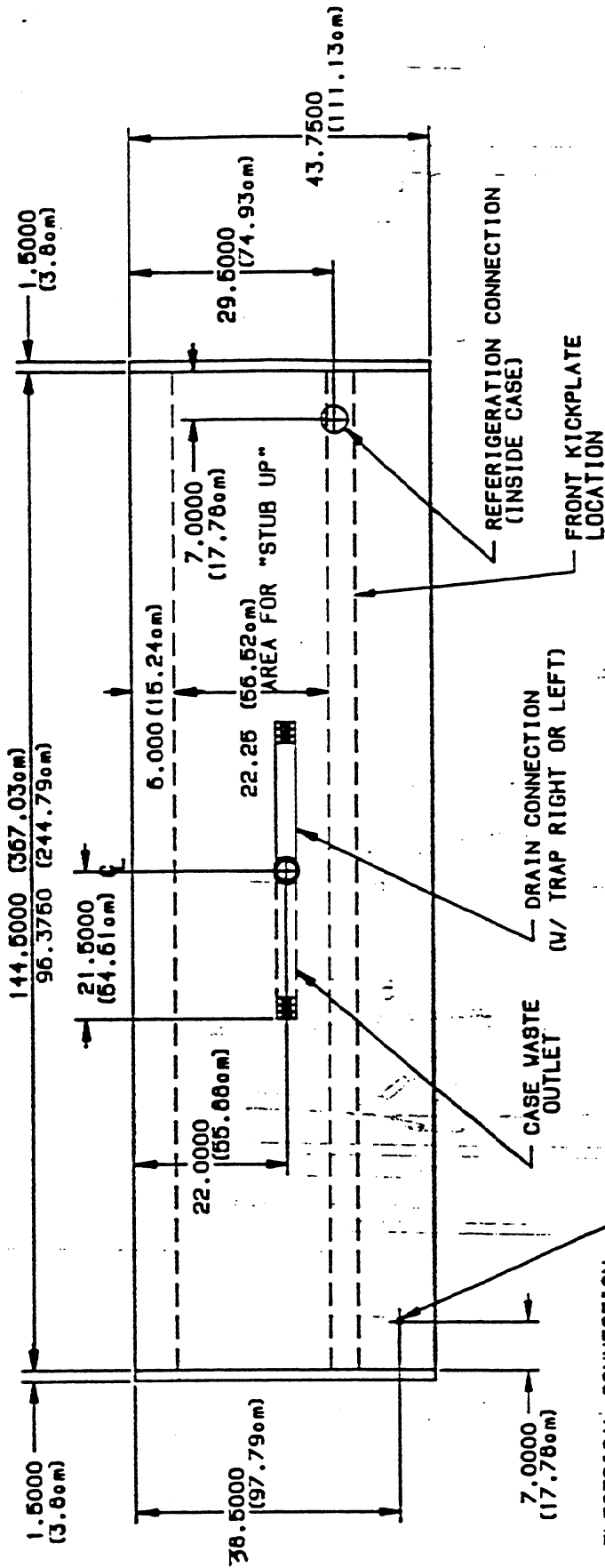

CASE FRONT

LETTER	REVISED	DATE	BY
DATE	TITLE		
10/21/88	FRAN VIEW - M41 8#12		
SCALE	DRAWING NUMBER		
NONE	PA-300AFT		
DRAWN	DIVISION OF KYSOR INDUSTRIAL CORPORATION		
B. TOOMBS	WARREN/SHERER		
APRD. JB	KYSOR		

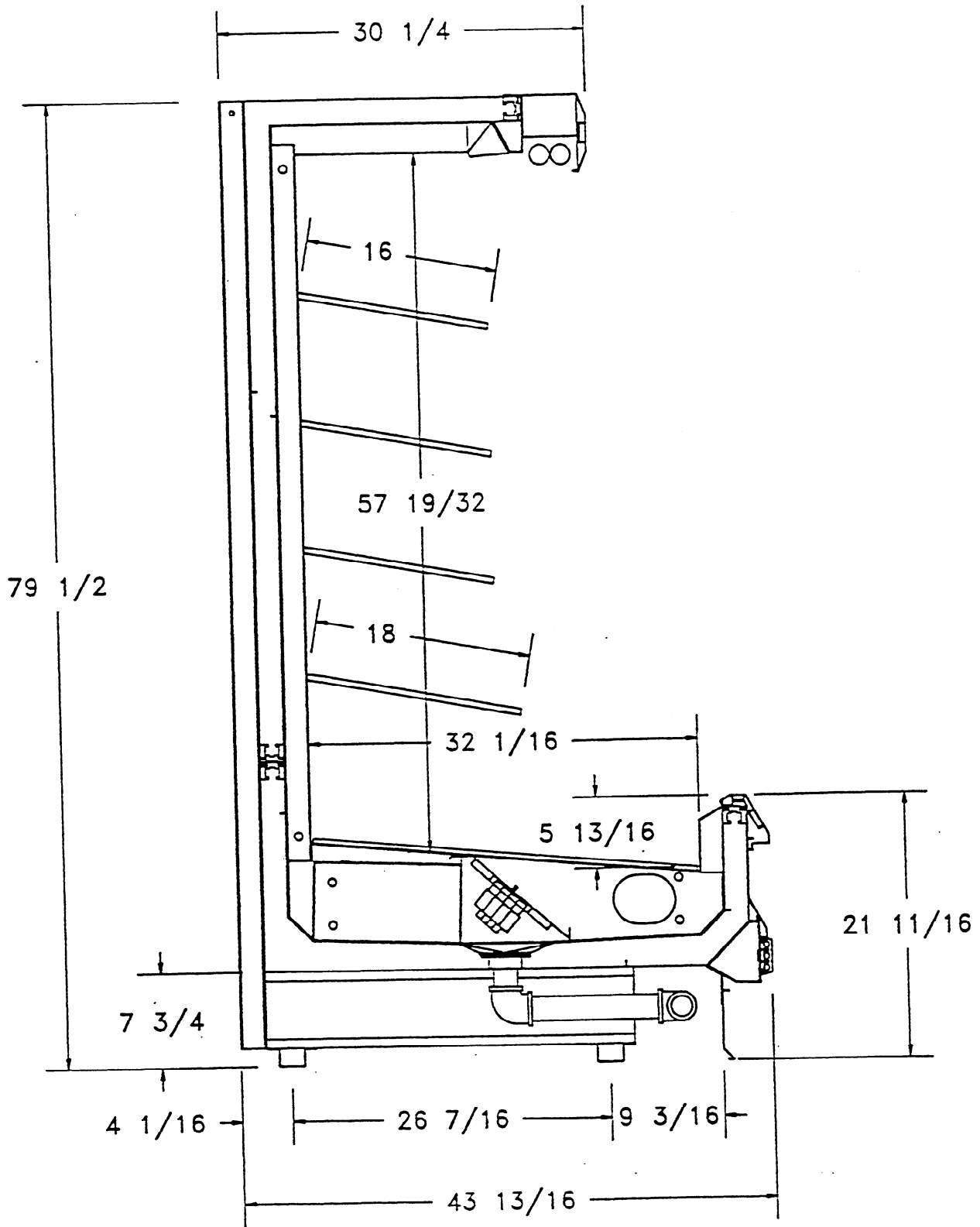

M51

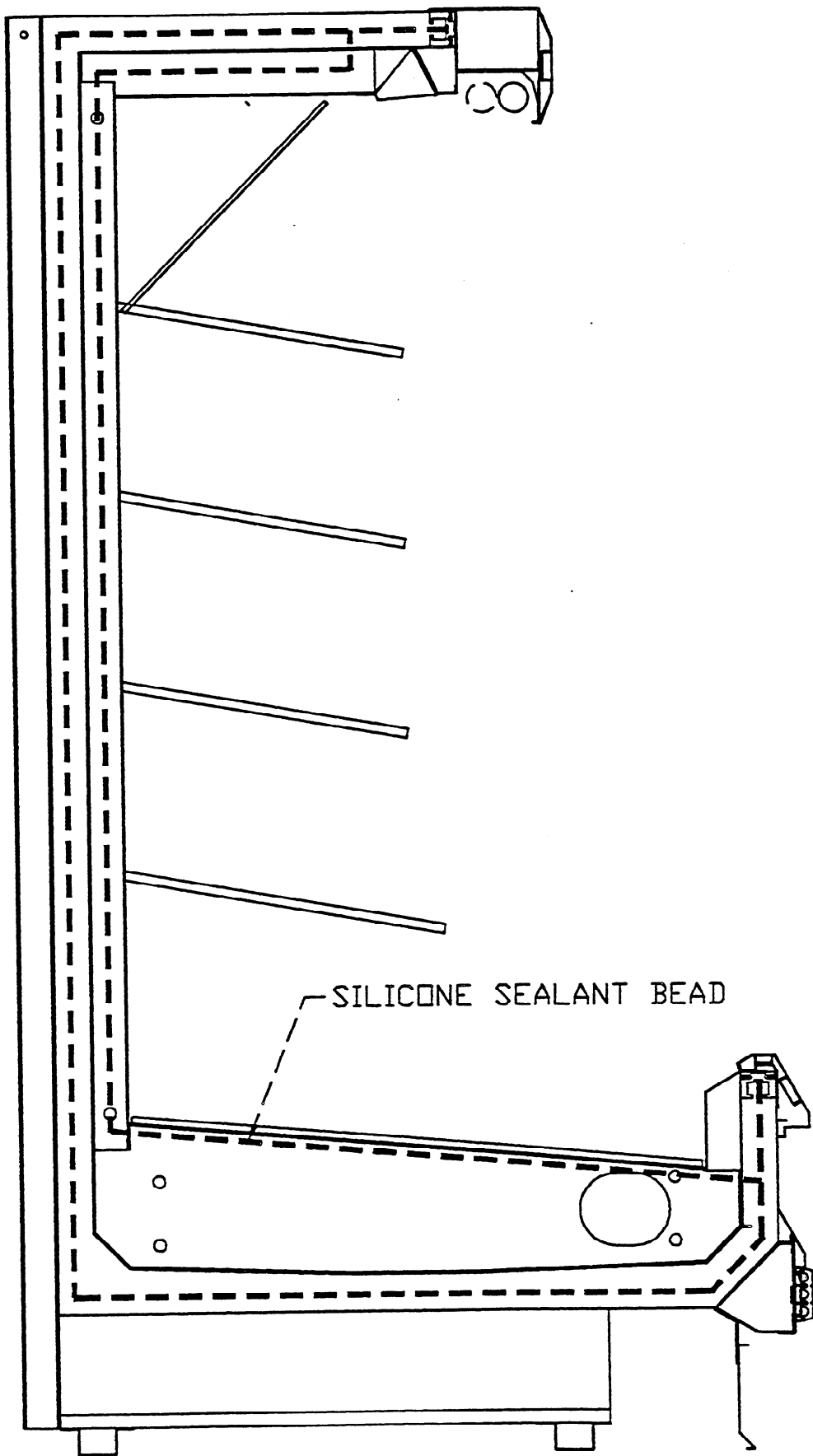

M51

CASE REAR

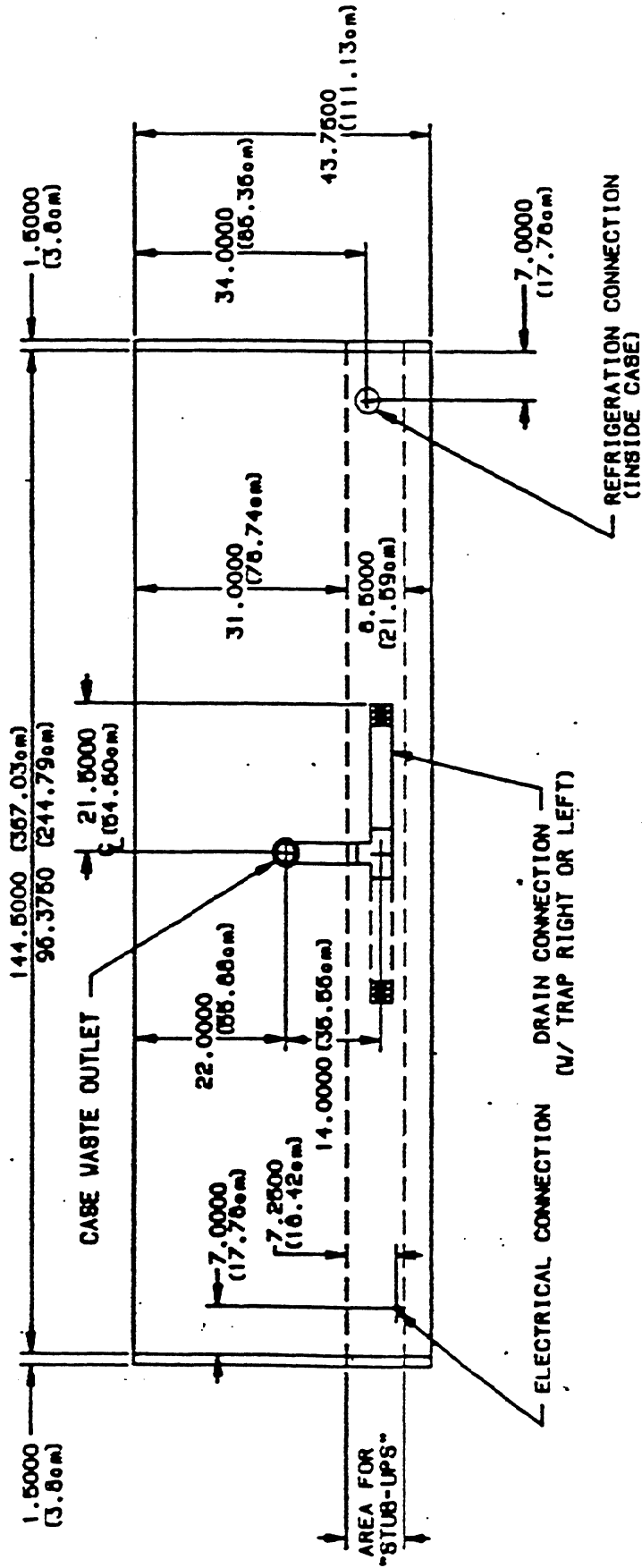

CASE FRONT

LETTER	REVISED	DATE	BY
TITLE			
RAW VIEW - D6(L)(H) 1 8#12			
M51 8#12			
DATE		DRAWING NUMBER	
10/21/88		PA-30048A	
SCALE		DRAWING NUMBER	
NONE		PA-30048A	
DRAWN		DRAWING NUMBER	
BITOMBS		PA-30048A	
APP'D		DRAWING NUMBER	
EAB		PA-30048A	

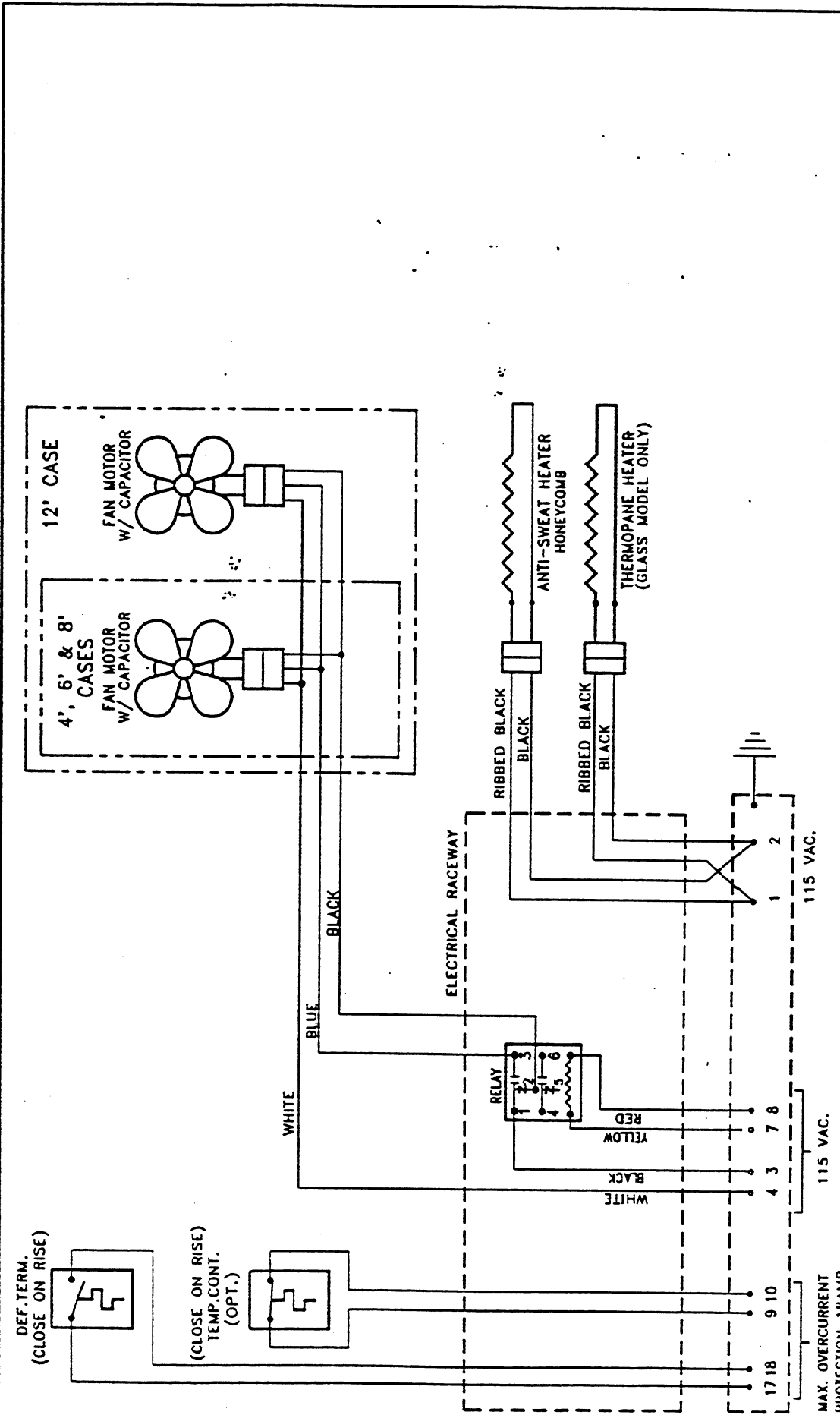

NOTE : CASE SHOWN IN REFRIGERATION MODE

M.T.L.	-	-				SUBJ: S1A(G)1-4, 6, 8, 12 M/A(G)1(SD)-6, 12	
BLK.	-	-				DESC: DIAG-CASE WIRING, AIR DEFROST	
PP#							
QTY.	-					OTHER	± 1/10
PTD.						SHEAR	± 1/32
PCN.	94012					SCALE	CAD
DRAWN	HEB					REV.	-
APPROVED	MS					DRAWN	3-29-94
ACTIVITY						BY	
						DATE	

REV	PCN NO.	DATE	BY	DESCRIPTION
A	92098	7-1-92	TAL	REDRAWN, WAS ON PB-30108
B	94012	3-29-94	HEB	REDRAWN

M.P. 31C10-429
DWG. PB-41111

KYSOR WARREN
DIVISION OF KYSOR INDUSTRIAL CORPORATION

31C10-783

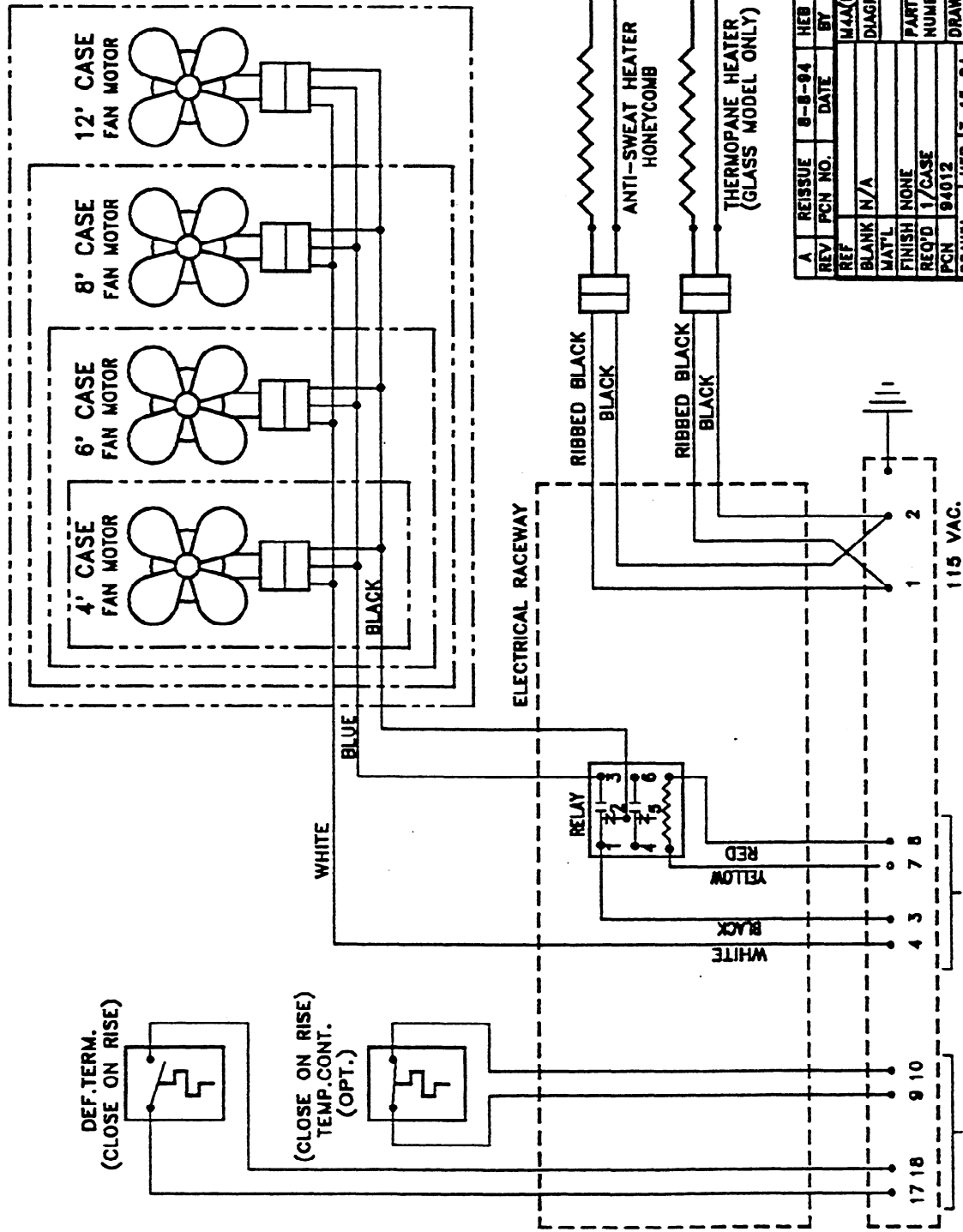

MAX. OVERCURRENT PROTECTION 18AMP.

NOTE : CASE SHOWN IN REFRIGERATION MODE

A	REISSUE	8-8-94	HEB	REMOVE "W/CAPACITOR" NOTE
REV	PCH NO.	DATE	BY	DESCRIPTION
REF				MAX(LXG)1-4 8 8 12 N3A(G)-6 8 12
BLANK	N/A			DIAGRAM--CASE WIRING, AIR DEFROST
MAT'L				
FINISH	NONE			
REQ'D	1/CASE			
PCH	94012			
DRAWN	HEB	3-18-94		
APPROVED				
OTHER TOL.	± 1/16			
SHEAR TOL.	± 1/32			
PART NUMBER		31C10-783		REV A
DRAWING NUMBER		PB-43468		
DIVISION OF KYSOR INDUSTRIAL CORPORATION				

31C10-784

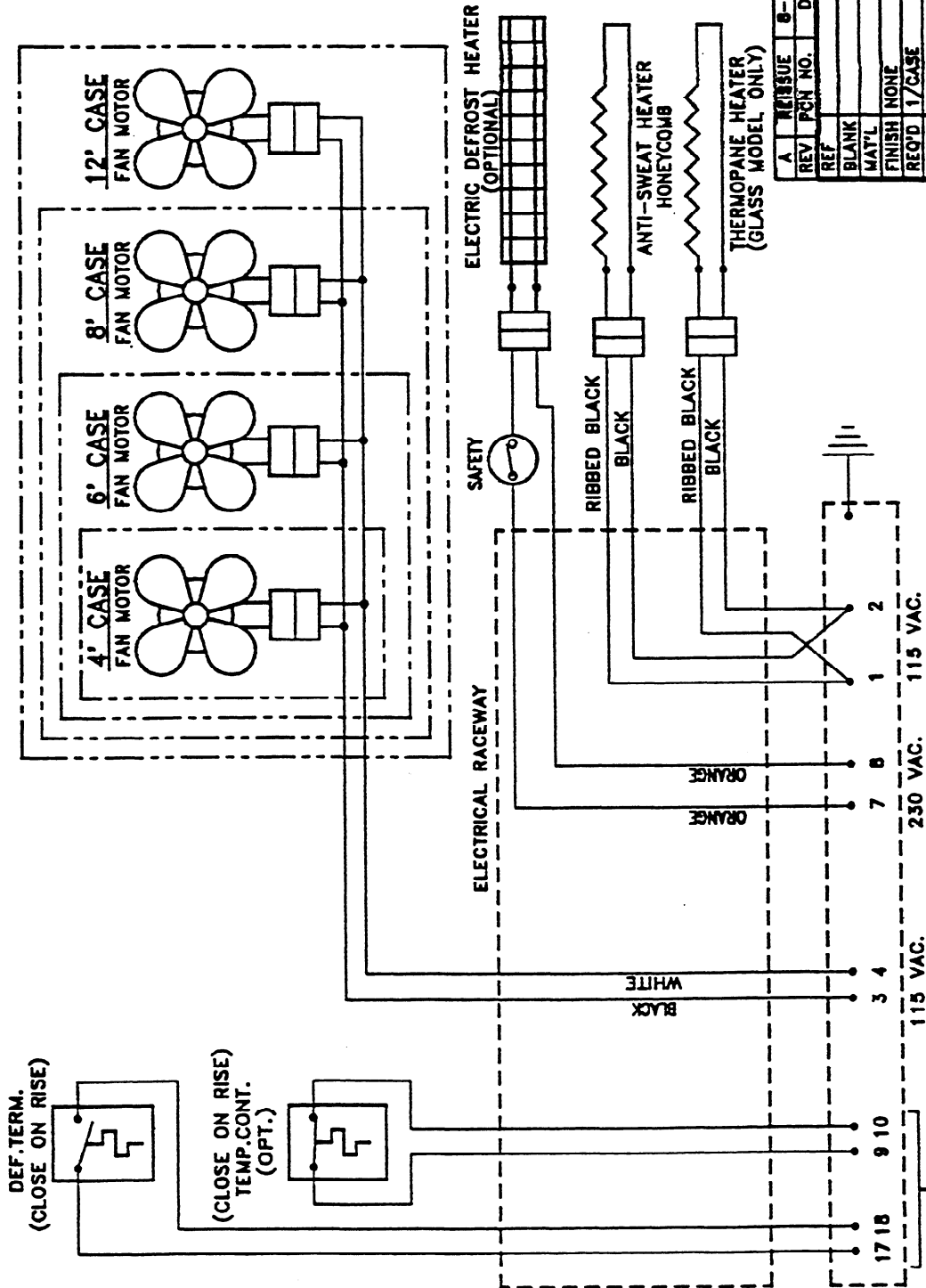

MAX. OVERCURRENT PROTECTION 18AMP.

NOTE : CASE SHOWN IN REFRIGERATION MODE

REV	PCN NO.	DATE	BY	DESCRIPTION
A	REISSUE	8-8-94	HEB	RELOCATE SAFETY SWITCH
REF	MAX(LXO)	1-4 6 8 12	M3A(O)	1-6 8 12
BLANK				DIAGRAM-CASE WIRING, OFF CYCLE,
MAT'L				ELECTRIC, & HOT GAS DEFROST
FINISH	NONE			
REQ'D	1/CASE			
PCN	94012			
DRAWN	HEB	3-18-94		
APPROVED				
OTHER TOL		±1/16		
SHEAR TOL		±1/32		

DRAWING NUMBER 31C10-784 REV A
 DRAWING NUMBER PB-43469
 KYSOR INDUSTRIAL CORPORATION
 DIVISION OF KYSOR INDUSTRIAL CORPORATION

31C10-859

4 FT CASES

6/8 FT CASES

12 FT CASES

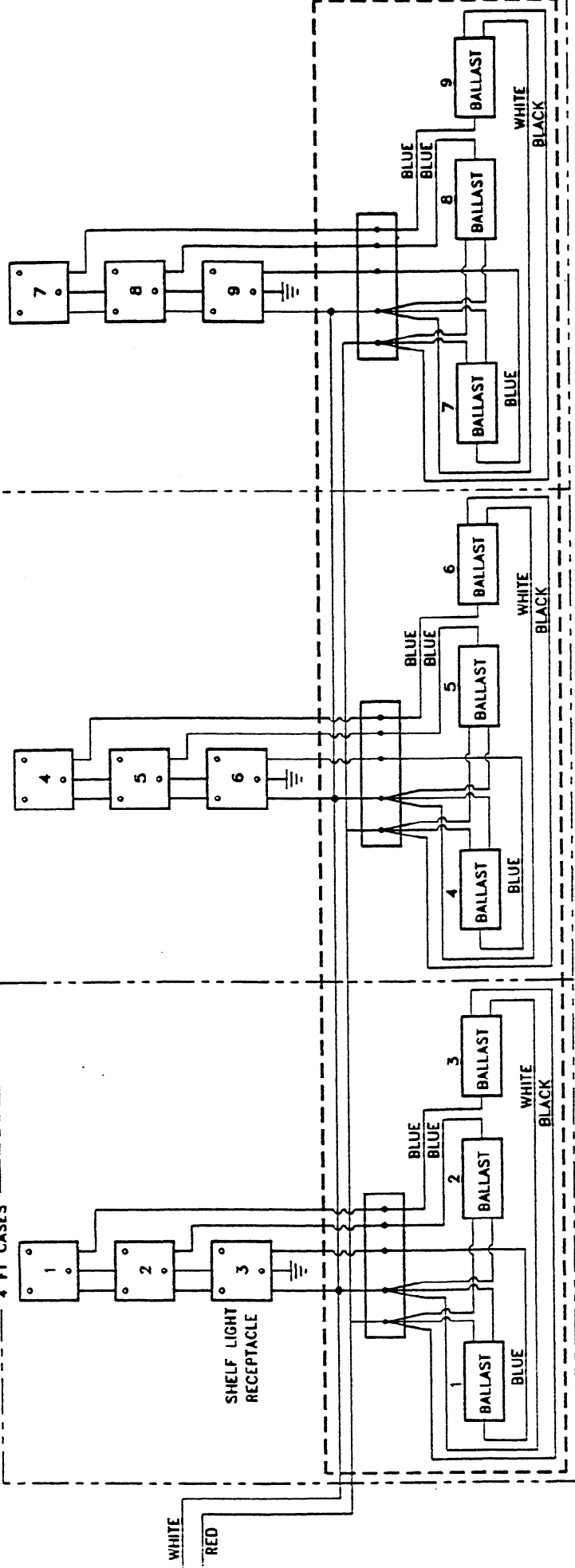

ELECTRICAL RACEWAY

CAUTION: SHELF RECEPTACLE HAS BALLAST VOLTAGE.
DO NOT USE FOR 120V. APPARATUS.

REF	MAJGT, MAX(CX)1
MAT'L	DIAG - WIRING SHELF 3 ROW
BLANK	MAGNETIC REMOTE BALLAST T-12
FINISH	PART NUMBER 31C10-859
REQ'D	REV
1/RIT	DRAWING NUMBER PB-44227
PCN 94108	TAL 6-24-94
APPROVED	OTHER TOL. ±1/16
SIFAR TOL.	11/37

31C10-860

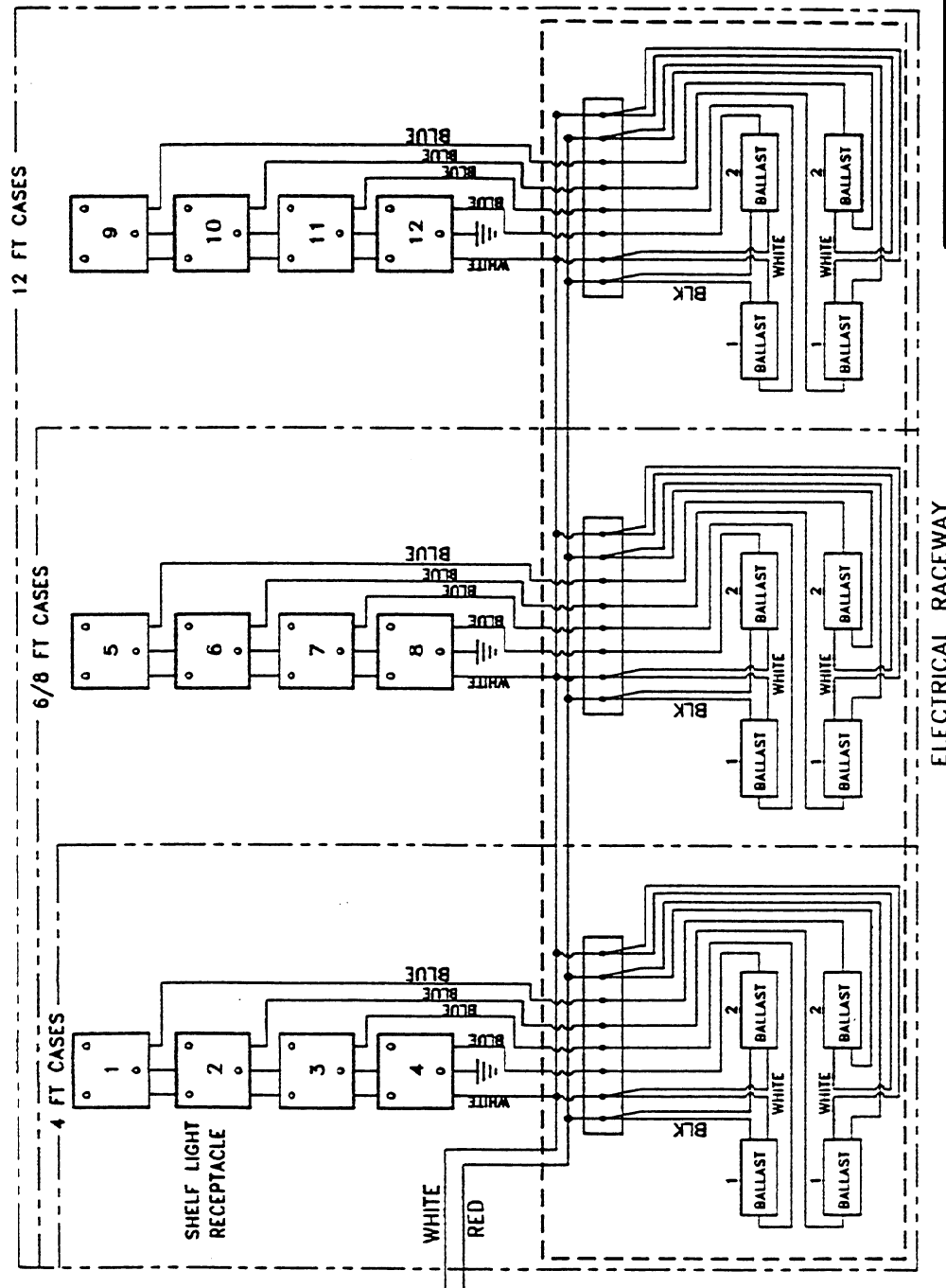

REF	M5(G)1
MAT'L	DIAG - WIRING SHELF 4 ROW
BLANK	MAGNETIC REMOTE BALLAST T-12
FINISH	PART NUMBER 31C10-860
REQ'D	REV
PCN	94108
DRAWN	TAL 6/25/94
APPROVED	
OTHER TOL.	± 1/16
SHELF TOL.	1 1/32
 KYSOR INDUSTRIAL CORPORATION	

CAUTION: SHELF RECEPTACLE HAS BALLAST VOLTAGE.
DO NOT USE FOR 120V. APPARATUS.

31C10-865

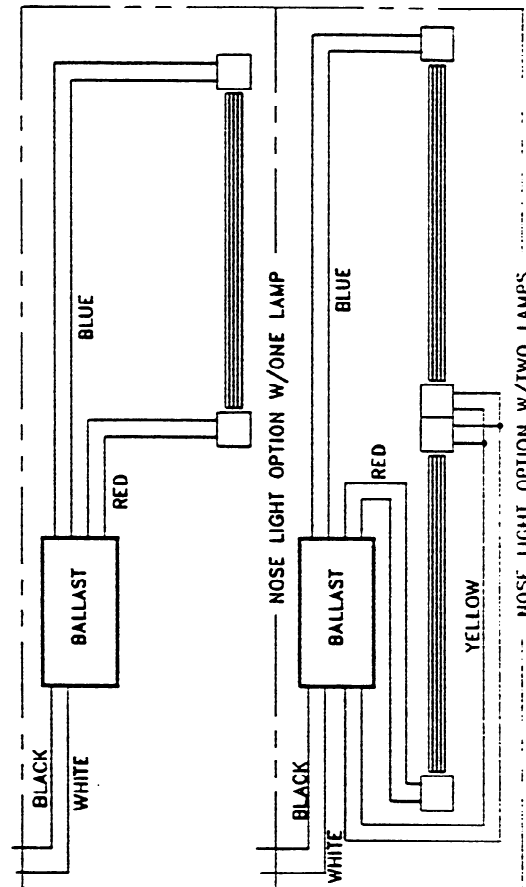
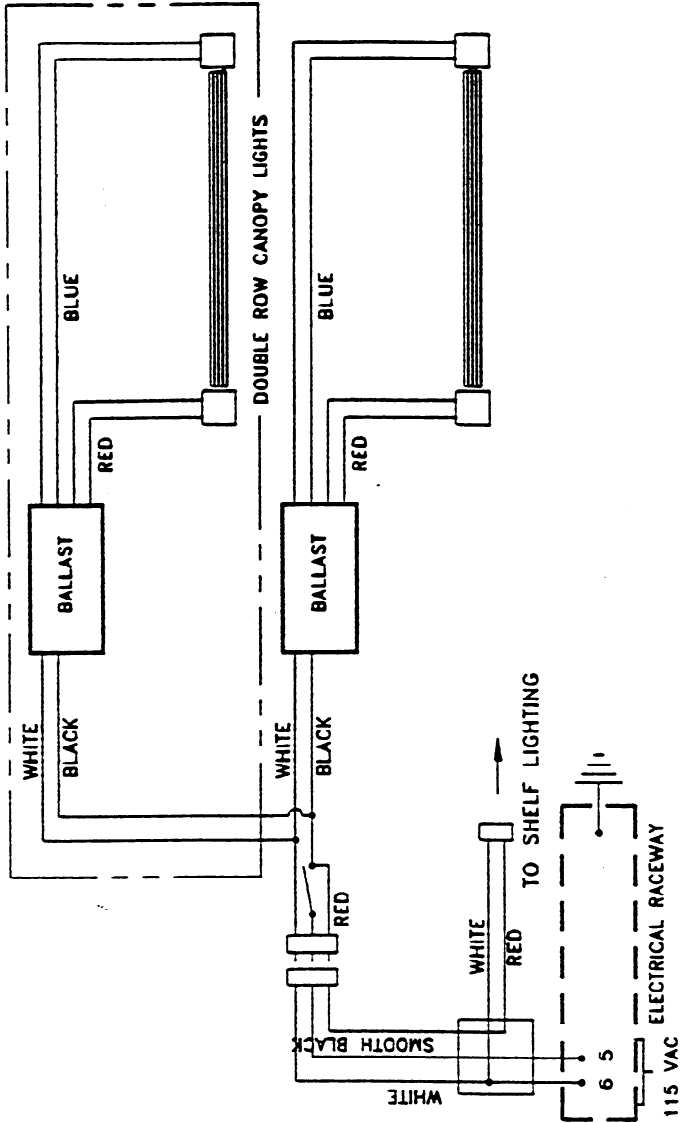
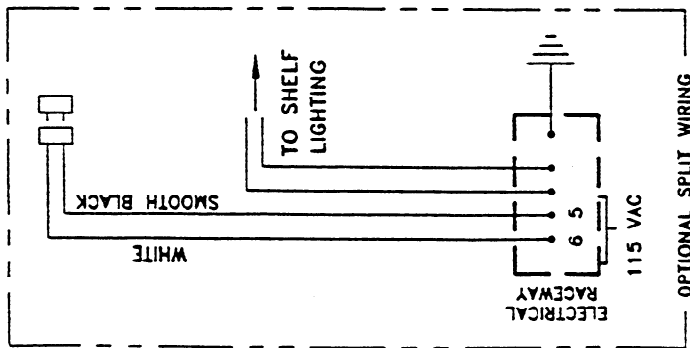

REF	2500 SERIES
MAT'L	DIAG-WRNG CNPY LGTS 1 LAMP/ROW
BLANK	
FINISH	
REQ'D 1/KIT	PART NUMBER 31C10-865 REV
PCH 94108	DRAWING NUMBER PB-44233
DRAWN TAL 6/25/94	
APPROVED	
OTHER TOL.	± 1/16
SHEAR TOL.	± 1/32



31C10-866

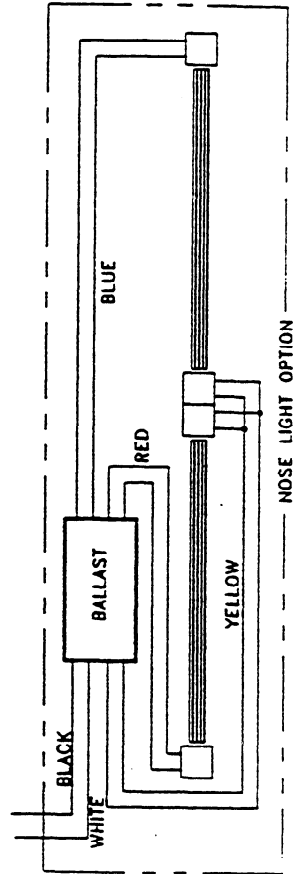
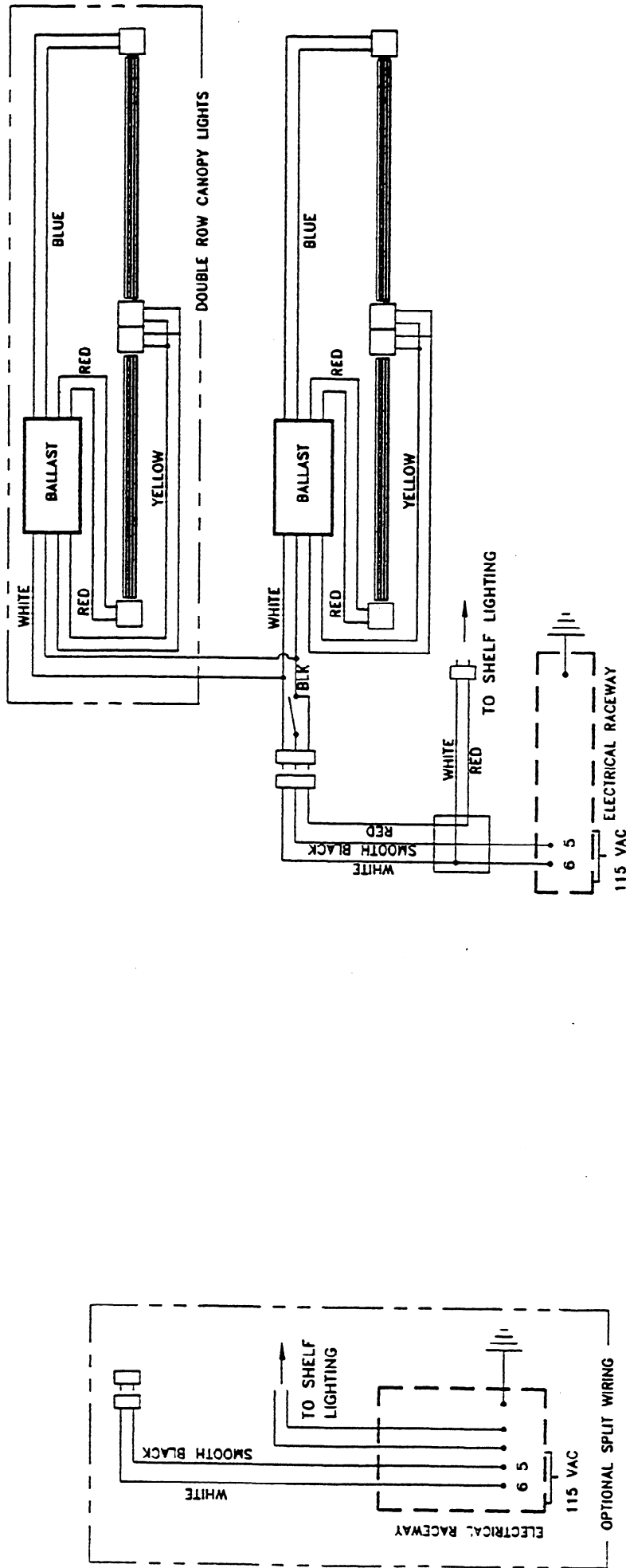

REF	DIAG-WRNG CNPY LGTS 2 LAMP/ROW
MAT'L	
BLANK	
FINISH	
REQ'D	1/KIT
PCN	94108
DRAWN	TAL 6/25/94
APPROVED	
OTHER TOL.	±1/16
SHEAR TOL.	11/32
PART NUMBER	31C10-866
DRAWING NUMBER	PB-44234
REV	



31C10-867

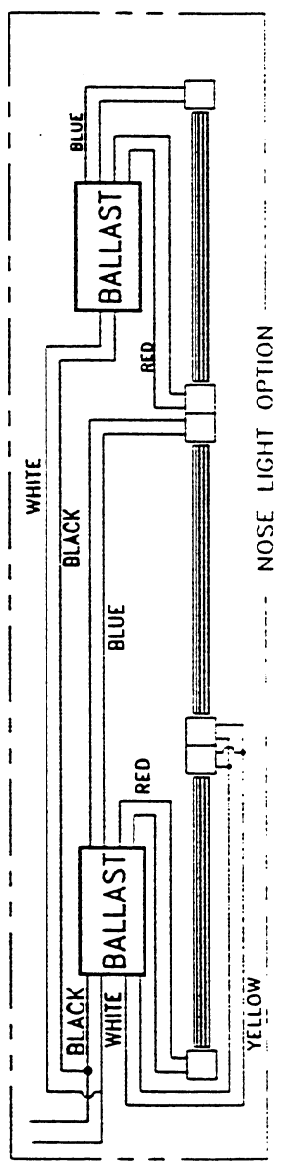
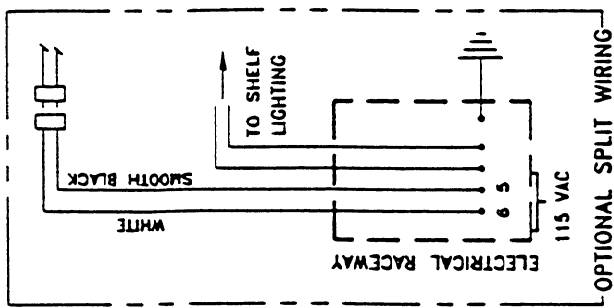
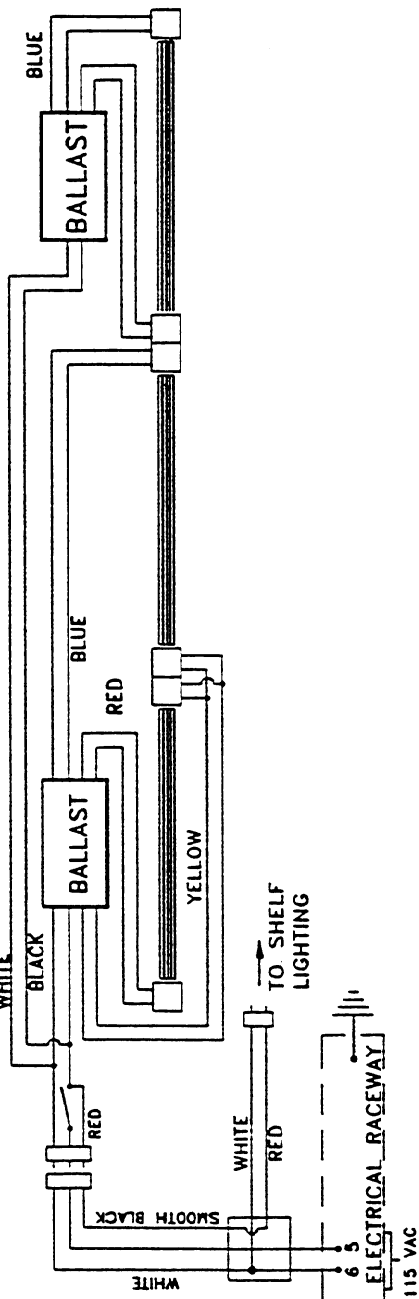
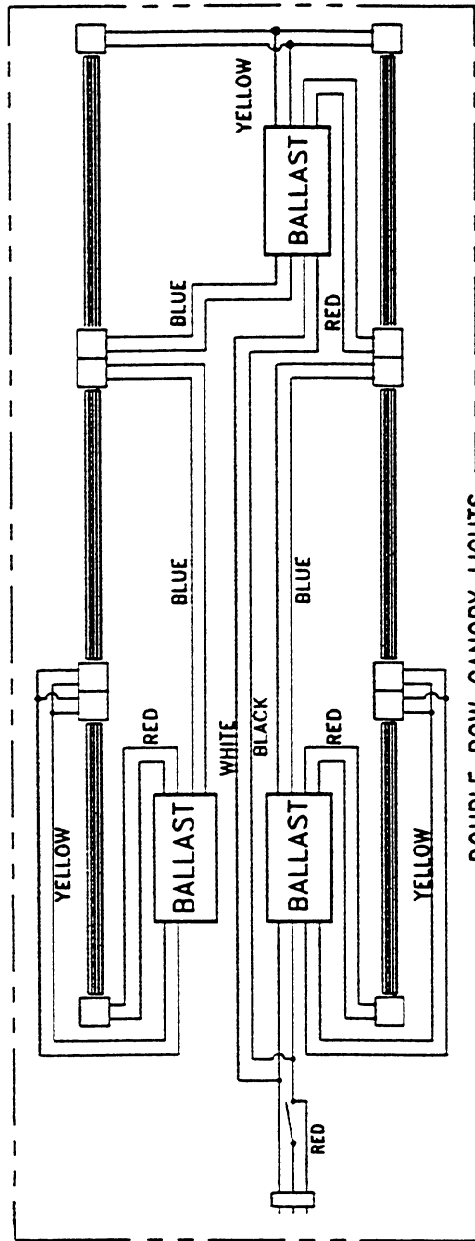

REF	MAT'L	2500 SERIES
BLANK	FINISH	DIAG-WRNG CNPY LTS 3 LAMPS/ROW
REQ'D	PCN	PART NUMBER
1/KIT	94108	31C10-867
DRAWN	TAL	DRAWING NUMBER
6/25/94		PB-44235
APPROVED	OTHER TOL.	DATE
		1/1/92
SUNAR TOL		1/1/92
 DIVISION OF KYSER INDUSTRIES CORPORATION		

31C10-851

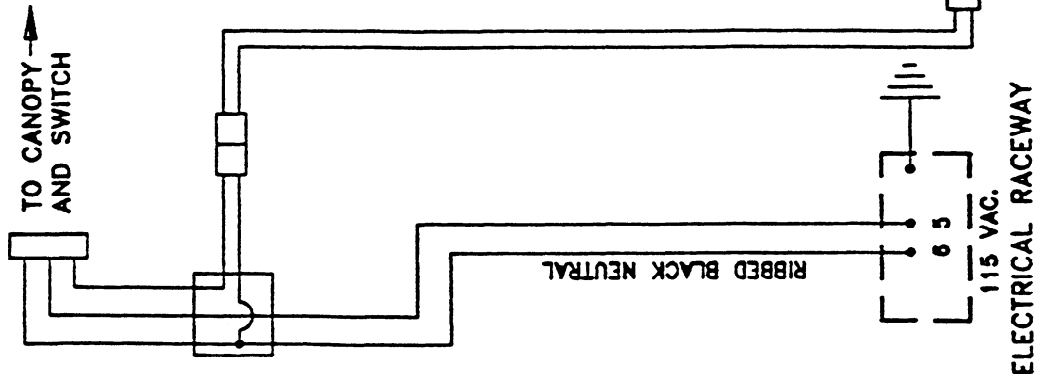
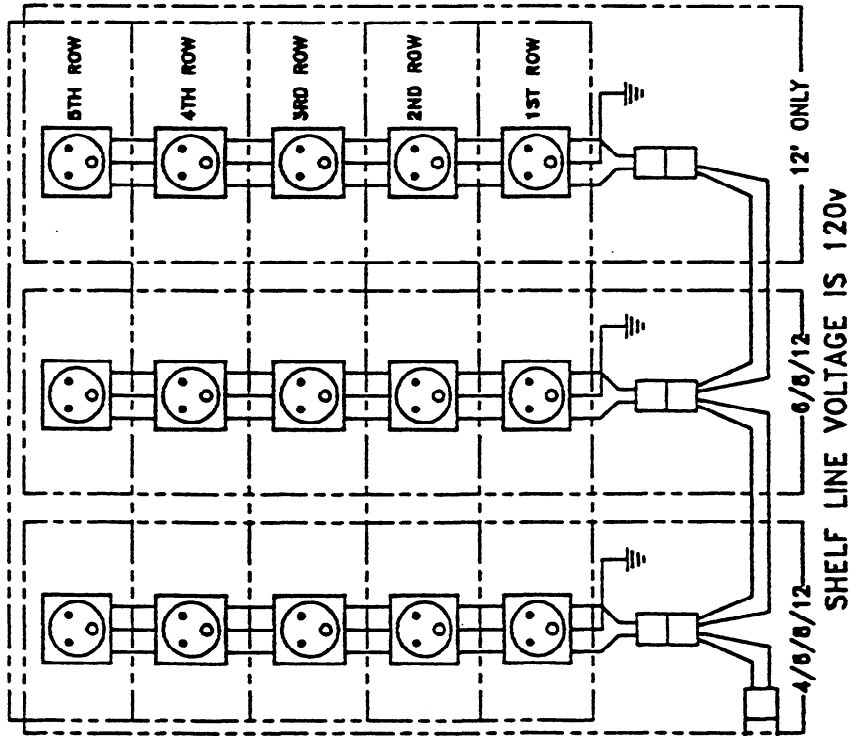
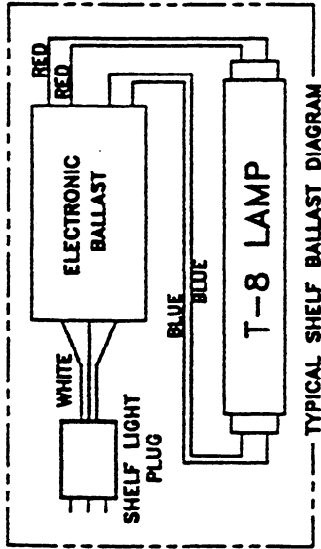
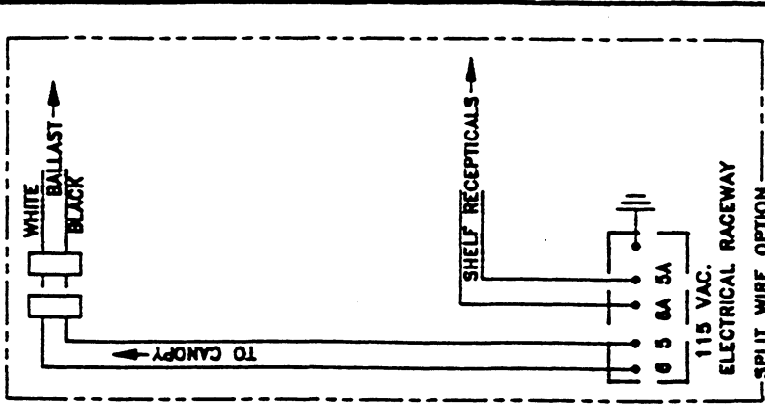

REF	2500 SERIES
MAT'L	DIAGRAM -- WIRING E.B. ON SHELF
BLANK	ELECTRONIC BALLAST ON SHELF
FINISH	NONE
REQ'D	1/KIT
PCN	94102
DRAWN	TAL 06/15/84
APPROVED	
OTHER TOL.	±1/16
SHEAR TOL.	±1/32
PART NUMBER	31C10-851
DRAWING NUMBER	PB-44204
KYSON DIVISION OF KYSON INDUSTRIAL CORPORATION	

31C10-862

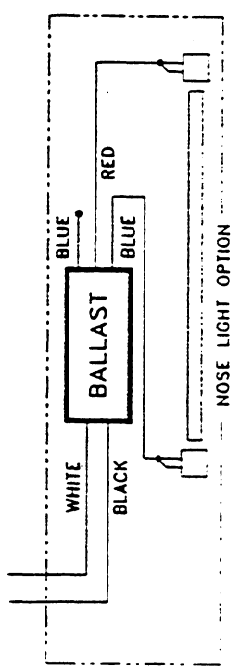
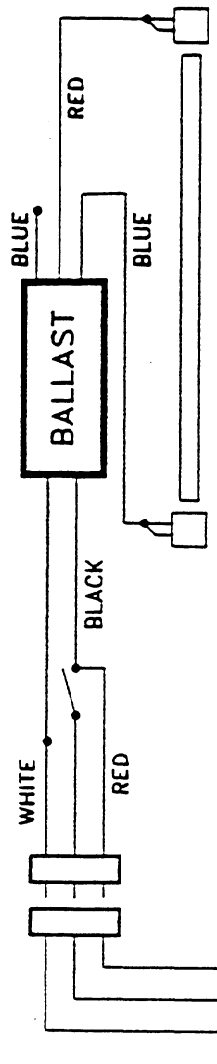
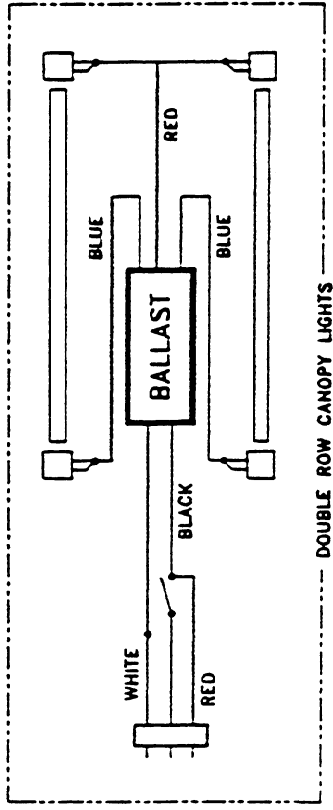
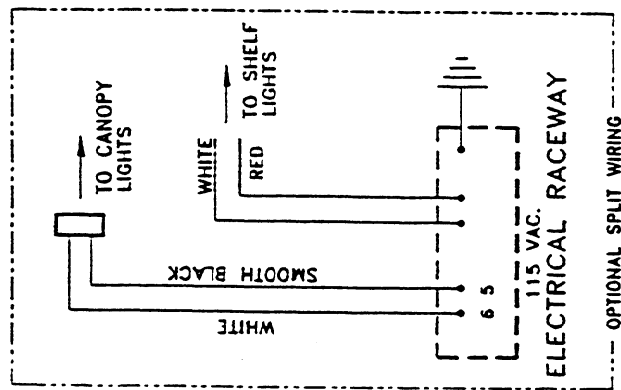

ELECTRICAL RACEWAY

REF	2500 SERIES		
MAT'L	DIAG-WRNG CNPY LT 1 LT/ROW ED		
BLANK			
FINISH			
REQ'D	1/KIT		
PCN	94108		
DRAWN	TAL	6/27/94	
APPROVED			
OTHER TOL.	±1/16		
SHEAR TOL.	1/32		
	PART NUMBER	31C10-862	
	DRAWING NUMBER	PB-44230	
	KYSOR INDUSTRIAL CORPORATION		

31C10-863

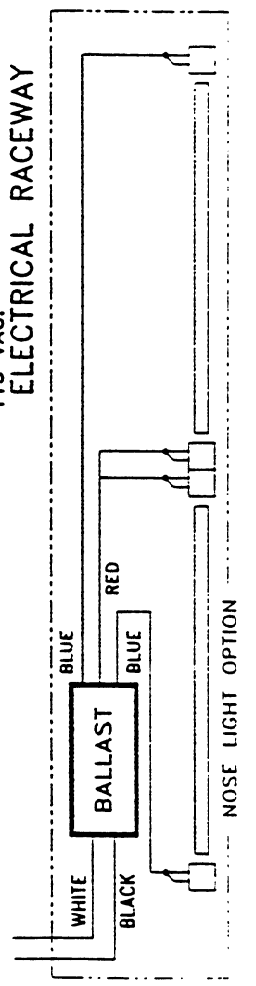
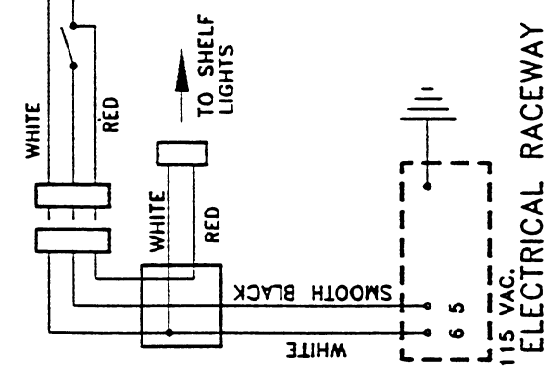
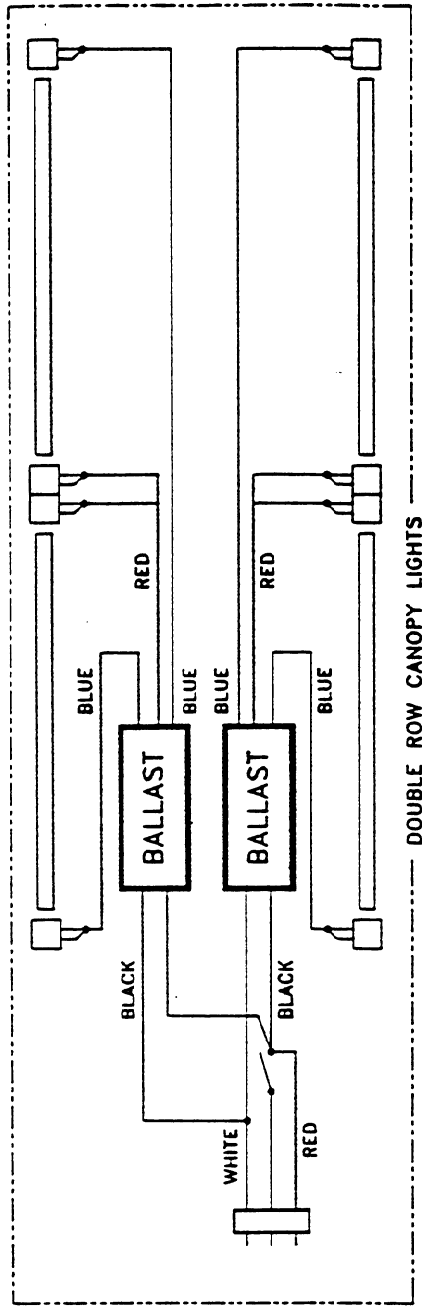
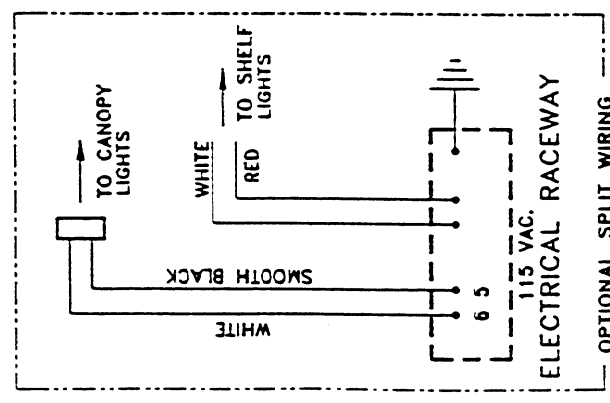

REF		2500 SERIES
MAT'L	DIAG - WRNG CNPY 2 LTS/ROW EB	
BLANK		
FINISH		
REQ'D	1/KIT	REV
PCN	94108	DRAWING NUMBER
DRAWN	TAL 6/27/94	PB-44231
APPROVED		
OTHER TOL.	±1/16	
SUFAR TOL.	1/1/32	

MYSA
 DIVISION OF KYSOR INDUSTRIAL CORPORATION

31C10-864

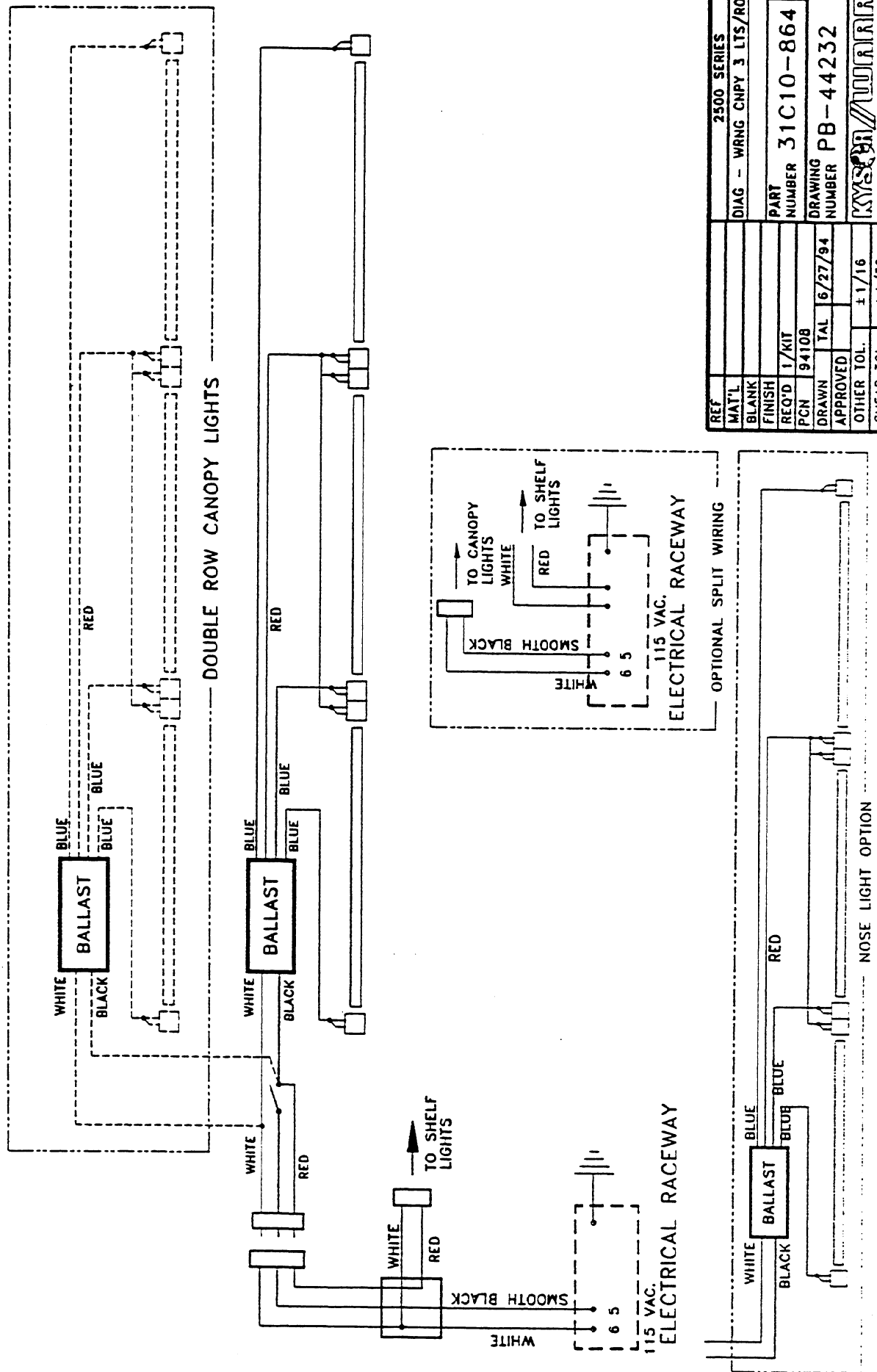

REF	MAT'L	2500 SERIES
BLANK	DIAG - WRNG CNPY 3 LTS/ROW EB	
FINISH		
REQ'D	1/KIT	PART NUMBER 31C10-864 REV
PCN	94108	DRAWING NUMBER PB-44232
DRAWN	TAL 6/27/94	
APPROVED		
OTHER TOL.	±1/16	
SHEAR TOL.	±1/32	
 DIVISION OF KYSOR INDUSTRIAL CORPORATION		

IN THE CONSTANT EFFORT TO IMPROVE OUR PRODUCTS, WE RESERVE THE RIGHT TO CHANGE AT ANY TIME SPECIFICATIONS, DESIGN, OR PRICES WITHOUT INCURRING OBLIGATION.

KYSOR // WARREN

DIVISION OF KYSOR INDUSTRIAL CORPORATION

P.O. Box C
1600 Industrial Blvd.
Conyers, Georgia 30207
404 483-5600

ONE-YEAR WARRANTY

KYSOR/WARREN warrants to the original purchaser this new equipment and all parts thereof, to be free from defects in material and workmanship under normal use and service. If any part or parts of the equipment should prove defective during the period of one year from installation date (not to exceed one year and thirty days from the date of original shipment from the factory), KYSOR/WARREN hereby guarantees to replace or repair, without charge (F.O.B. CONYERS, GEORGIA), such part or parts as prove defective, and which KYSOR/WARREN's examination discloses to its satisfaction to be thus defective, with a new or functionally operative part. The liability of KYSOR/WARREN under this warranty shall be limited to claims made by the original purchaser to KYSOR/WARREN or its local distributor within the warranty period.

GLAZING: Glass is not guaranteed against breakage. If this refrigerator is equipped with a glazing assembly carrying the manufacturer's brand name (Thermopane, Twindow, etc.), the manufacturer's glazing warranty in effect at the time of this shipment is extended to that assembly. It is void outside the continental United States.

THIS WARRANTY IS IN LIEU OF ALL OTHER WARRANTIES, EXPRESSED, IMPLIED OR STATUTORY, INCLUDING, BUT NOT LIMITED TO ANY WARRANTY OF MERCHANTABILITY OR FITNESS, AND ALL OTHER OBLIGATIONS OR LIABILITIES OF KYSOR/WARREN.

THIS WARRANTY SHALL NOT APPLY:

1. To the condensing unit used with refrigerated equipment unless same was sold and shipped by KYSOR/WARREN.
2. When this equipment or any part thereof is damaged by fire, flood, act of God, or when the original model and serial—number plate has been altered, defaced, or removed.
3. When this equipment or any part thereof is subject to accident, alteration, abuse, misuse, tampering, operation on low or improper voltages, or is put to a use other than recommended by KYSOR/WARREN.
4. When this equipment or any part thereof is damaged, or when operation is impaired, due to failure to follow installation manual (improper installation is the responsibility of the installer).
5. Outside the continental United States.
6. To labor cost for replacement of parts, or for freight or shipping expenses.
7. If the Warranty holder fails to comply with all the provisions, terms and conditions of this Warranty.

Parts replaced under this Warranty are warranted only through the remainder of the original Warranty. KYSOR/WARREN may, at its option and in its discretion, elect to honor this Warranty and to disregard the original purchaser's noncompliance with any of the provisions, terms and conditions of this Warranty.

THIS WARRANTY DOES NOT COVER CONSEQUENTIAL DAMAGES.

KYSOR/WARREN shall not be liable under any circumstances for any consequential damages, including loss of profits, additional labor costs, loss of refrigerant or food products, or injury to person or property caused by defective material or parts or for any delay in the performance of this Warranty due to causes beyond its control. The foregoing shall constitute the sole and exclusive remedy of any purchaser and the sole and exclusive liability of KYSOR/WARREN in connection with this product.