

**KYSOR // WARREN**

*The Leading Edge Of Technology*

---

# INSTALLATION & OPERATION MANUAL

---

MODEL: **S39S(J)(F)1 S35S(J)(F)1**

**DELI/MEAT/FISH**

---

THIS REFRIGERATOR CONFORMS TO THE COMMERCIAL  
REFRIGERATOR MANUFACTURERS ASSOCIATION HEALTH  
AND SANITATION STANDARD.

**KYSOR // WARREN**

*DIVISION OF KYSOR INDUSTRIAL CORPORATION*

1600 INDUSTRIAL BLVD., CONYERS, GEORGIA 30207 / 770-483-5600  
5201 TRANSPORT BLVD., COLUMBUS, GEORGIA 31907

# INSTALLATION AND OPERATING INSTRUCTIONS

## FOR

### S39S(J)(F)1, S35S(J)(F)1 MODELS

### SERVICE DELI/MEAT/FISH CASES

---

#### *APPLICATION*

The Kysor/Warren service case is designed to merchandise unpackaged fresh meat, fish and delicatessen products. The forced air model should only be used for deli, while the gravity coil model can be used for deli, fish or fresh meat. These cases should be installed and operated according to the instructions contained in this manual to insure proper performance. They are designed for the display of products in an air-conditioned store where temperature and humidity are maintained at a maximum of 75 degree F dry bulb, 55% relative humidity.

<i>MODELS</i>	<i>DESCRIPTION</i>
S39SJ1	Service Deli - 29" Front Glass Forced Air Coil Remote Refrigeration
S35SJ1	Service Deli - 25" Front Glass Forced Air Coil Remote Refrigeration
S39S1	Service Meat - 29" Front Glass Gravity Coil Remote Refrigeration
S35S1	Service Meat - 25" Front Glass Gravity Coil Remote Refrigeration
S39SF1	Service Fish - 29" Front Glass Gravity Coil (Top Only) Remote Refrigeration
S35SF1	Service Fish - 25" Front Glass Gravity Coil (Top Only) Remote Refrigeration

## NOTICE TO INSTALLER

### CAUTION

WHEN MOVING THIS CASE, LIFT IT AS EVENLY AS POSSIBLE TO PREVENT TWISTING WHICH CAN CAUSE THE GLASS TO BREAK.

### WARNING

BEFORE INSTALLING THIS CASE, CHECK THE ENTIRE FLOOR SURFACE ON WHICH THE CASE WILL BE PLACED. THE ENTIRE BASE MUST BE PROPERLY SHIMMED UNDER EACH BASE LEG FRONT AND REAR TO PREVENT SETTLING AND TWISTING OF THE CASE. FAILURE TO PROPERLY SUPPORT THE BASE OF THE CASE AT EACH LEG LOCATION CAN WARP THE GLASS MOUNTING CHANNEL WHEN THE CASE IS LOADED CAUSING TO BREAK.

## NOTICE TO OWNER OR OPERATOR

### WARNING

FAILURE TO PROPERLY INSTALL AND SUPPORT THE BASE OF THIS CASE CAN CAUSE FUTURE GLASS BREAKAGE WHEN THE CASE IS LOADED AND PLACED IN OPERATION.

### CAUTION

BEFORE LOADING AND OPERATING THIS CASE, CHECK TO SEE THAT THE INSTALLER HAS SUPPORTED EACH BASE LEG FRONT AND REAR. IF THERE ARE AIR SPACES BETWEEN THE FLOOR AND ANY BASE LEG, THE CASE CAN TWIST WHEN LOADED CAUSING SUBSEQUENT GLASS BREAKAGE.

## **GENERAL**

These display refrigerators may be installed individually or in a continuous line-up consisting of several 8' and 12' sections by using a joint trim kit. A plexiglass divider kit must be used between cases operating on different refrigeration systems. Divider will be factory installed if specified on order.

## **SHIPPING DAMAGE**

All equipment should be examined for shipping damage before and during unloading. If there is any damage, the carrier should be notified immediately and an inspection requested. The delivery receipt must be noted that the equipment was received damaged. If damage is of concealed nature you must contact the carrier immediately or no later than three days following delivery. A claim must be filed with the carrier by the consignee for all damages.

**NOTE: ALL CLAIMS FOR SHORTAGES MUST BE MADE WITHIN 10 DAYS AFTER RECEIPT OF SHIPMENT.**

## **LOCATION**

This refrigerator must be located on a firmly based floor and leveled within plus or minus 1/16". Use shims provided to level your refrigerator.

## **JOINING**

Two or more fixtures of like models can be joined together to form a continuous line-up. Instructions for joining fixtures are included in the joint kit. Before lining up refrigerator, inspect refrigeration lines, electrical connections and controls to insure refrigerators are in proper line-up and are in the proper sequence.

**NOTE: THESE REFRIGERATORS ARE LINE UP AT THE FACTORY AND ARE NUMBERED. INSURE THEY ARE LINED UP IN THE FIELD IN THE SAME SEQUENCE NUMBER.**

## **WASTE OUTLET**

These cases are equipped with a 1-1/2" FPI waste outlet connection which terminates in the center of the refrigerator below the insulation bottom. A 1-1/2" PVC water seal trap is provided for field installation.

## **INSTALLING DRIP PIPE**

Improperly installed drip pipes can seriously effect the operation of this equipment and result in increased maintenance cost. Listed below are some general rules for drip pipe installation.

Never use a double water seal.

Never use a pipe smaller than the size pipe or water seal supplied with the equipment.

Always provide as much fall as possible in drip pipe.  
(1" fall for each 4' of drip pipe.)

Avoid long runs in drip pipe which make it impossible to provide maximum fall in pipe.

Provide a drip space between drip pipe and floor drain or sewer connection.

Do not allow drip pipe to come in contact with uninsulated suction lines, which will cause the condensation from your refrigerator to freeze.

## **CLEANING**

**CAUTION: BE SURE THAT THE REFRIGERATION AND ALL ELECTRICAL POWER IS TURNED OFF BEFORE WASHING YOUR REFRIGERATOR.**

To insure proper sanitation and minimum maintenance cost, the refrigerator should be emptied and thoroughly washed out, at least once a week. The interior should be cleaned with a mild soap/water solution and a sanitizer. Never introduce water into the fixture faster than the outlet can carry it away.

The waste outlet should be flushed with clean water following each cleaning.

**DO NOT USE STEAM, EXTREMELY HOT WATER OR HIGH PRESSURE WASHING SYSTEMS TO CLEAN THE REFRIGERATOR, AS INTERIOR SEALS MAY BE BROKEN THAT WILL CAUSE THE CASE TO LEAK AND/OR CAUSE THE GLASS SURFACES TO BREAK.**

The exterior of the refrigerator should be cleaned with a mild soap and water solution, as necessary to maintain a good appearance.

**DO NOT USE CLEANERS CONTAINING ABRASIVE MATERIALS THAT WILL SCRATCH OR DULL THE PAINTED FINISH.**

When cleaning lighted shelves, wipe down with a wet sponge or cloth so that water does not enter the light rail. **DO NOT USE A HOSE OR SUBMERGE SHELVES IN WATER.**

### **LOADING**

Merchandise should not be placed in the fixture until all controls have been adjusted and the controls have been adjusted and the refrigerator is at proper temperature.

At no time should the fixture be stocked beyond the load line or over the front edge of adjustable shelves. In doing so, you will seriously affect the performance which will result in higher product temperatures and increase operating costs.

### **ELECTRICAL**

All field installed wiring must comply with the **NATIONAL ELECTRICAL CODES AND LOCAL CODES.**

### **ELECTRICAL JUNCTION**

On these cases, an electrical junction box is provided for field connections. The junction box is located along the rear of the case and contains the case thermostat, all lighting ballasts and receptacles.

### **ELECTRICAL CONNECTIONS**

All field connections are made in the electrical junction box.

Make sure that proper voltage is supplied to your refrigerator. Check refrigerator nameplate for correct circuits, volts, and amps. **ALL REFRIGERATORS MUST BE GROUNDED.**

When refrigerators are multiplexed, add the total of these amperage values to determine wire size and circuit protection.

Make sure that proper wire size and branch circuit protection are employed for safe operation.

Chart #1 shows the electrical ratings for your refrigerator. This is the same information that appears on your refrigeration nameplate.

### **REFRIGERATION FAN MOTORS (S39SJ1 & S35SJ1 ONLY)**

The fan motors employed are permanently oiled for the life of the motor and require no periodic maintenance. They are wired according to the enclosed wiring diagram and must run continuously.

## **EXPANSION VALVE**

The expansion valve furnished with your refrigerator has been sized for maximum coil efficiency. To adjust superheat, place a thermocouple under the expansion valve bulb. Read the suction line pressure as near coil as possible. (If at the condensing unit, estimate suction line loss at 2 PSIG.) Convert coil suction pressure to temperature. The difference between coil temperature and the thermocouple temperature is superheat. (Use average superheat when expansion valve is hunting.) Do not set superheat until cases have pulled down to operating temperature and never open or close valve over 1/4 turn between adjustments and allow 10 minutes or more between adjustments. Superheat should be set to 6 - 8-degree F.

**NOTE: ON S35S1 AND S39S1 CASES USED FOR FISH, THE EXPANSION VALVE BULB MUST BE MOVED FROM THE FRONT OF THE LOWER COIL TO THE REAR OF THE COIL. THIS WILL ALLOW THE LOWER COIL TO CLEAR DURING A DEFROST CYCLE.**

## **REFRIGERATION LINES**

Refrigeration connections (suction & liquid) are stubbed underneath the case. Cases multiplexed together must be field connected by running refrigerant lines in the space under the case. The field installed suction lines must be insulated to prevent condensation accumulation on the floor. See the section on "Recommended Piping Practices" for additional details on piping practices.

**NOTE: SEAL AROUND LINES AFTER CONNECTIONS ARE MADE. KEEP DIRECT FLAME FROM BOTTOM OF REFRIGERATOR, AS HEAT WILL DISINTEGRATE THE BOTTOM AND INSULATION. USE A HEAT SHIELD WHEN WELDING NEAR THE BOTTOM OF THE CASES.**

## **REFRIGERANT**

Expansion valves are supplied for the refrigerant specified on the original sales order.

## **HEAT EXCHANGER**

Heat exchangers are standard in these refrigerators. They aid to increase operating efficiency and reduce frosting and flood-back to compressor. Heat exchangers may not be used if mechanical sub-cooling is incorporated in the system design.

## **OPERATION**

On single condensing unit systems, a thermostat should be used to control temperatures. The thermostat bulb is mounted on the rear baffle on gravity coil models and in the discharge air on the forced air models. On parallel units, temperature control can be provided by EPR valve and thermostat. Chart #2 shows approximate settings for merchandisers. Since many variables are present in each installation, such as store temperature, length of tubing runs, temperature desired in refrigerator, etc.. Chart #2 is only a guide for the installer.

## DEHYDRATION OF REFRIGERATION SYSTEMS

PLEASE READ CAREFULLY BEFORE PLACING SYSTEM INTO OPERATION.

After laying refrigerant lines, they should be blown out before making final connection at fixture or condensing unit. Use dry nitrogen to prevent any foreign matter being left in the lines. Keep pressure below 250 pounds. To prevent scaling due to brazing, dry nitrogen should be allowed to flow through lines while brazing operations are taking place.

After the refrigeration system has been pressure-tested and proven leak-free, it is recommended that the system be dehydrated with a vacuum pump to 1000 microns for the first two evacuations and 500 microns on the third. The triple evacuation method requires evacuating the system three successive times and breaking the first two vacuums with dry nitrogen. The third vacuum would be broken with the refrigerant specified for the system.

**CAUTION: DURING INSTALLATION AND SERVICE OF THIS EQUIPMENT, PRECAUTIONS SHOULD BE TAKEN TO PREVENT LOSS OF REFRIGERANT TO THE ATMOSPHERE.**

## DEFROST CYCLE

Off-time defrost is standard on these models. The fans run continuously on the forced air cases. Defrost termination is by time (fail safe). See Chart #2 for defrost settings.

CHART #1			
ELECTRICAL RATINGS (115/60/1 PHASE)			
Model	Fan Amps	Light Amps	Receptacle Amps
S39SJ1/S35SJ1 8	.68	.8	15.0
S39SJ1/S35SJ1 12	1.02	1.3	15.0
S39S(F)1/S35S(F)1 8		.8	15.0
S39S(F)1/S35S(F)1 12		1.3	15.0

\*Cases are standard with one row of lights in the top front. A second row of lights can be added at the rear top. For the second row of lights, add .8 amps to 8' cases and 1.3 amps to 12' cases. If lighted shelves are used, add .64 amps for each shelf. This case can have a maximum of two rows of lighted shelves.



CHART #2			
RECOMMENDED CONTROL SETTINGS			
MODEL	REFRIGERANT	EPR SETTING	THERMOSTAT CUT-OUT    CUT-IN
S39SJ1/S35SJ1	R-12 (HCFC) R-134A (HFC) R-404a (HFC) R-507 (HFC)	43# 18# 56# 58#	28Dg F    32Dg F (Disch Air)
S39S(F)1/S35S(F)1	R-22 (HFC) R-134a (HFC) R-404a (HFC) R-507 (HFC)	43# 18# 56# 58#	34Dg F    38Dg F (Sensing Bulb at Product Level)

NOTE: ALL S3(9)(5)1 SERIES CASE TEMPERATURES SHOULD BE CONTROLLED WITH A THERMOSTAT AND EPR VALVE. ON CONVENTIONAL CONDENSING UNITS, THE THERMOSTAT SHOULD CYCLE THE CONNECTED COMPRESSOR. ON PARALLEL REFRIGERATION SYSTEMS, THE THERMOSTAT MUST CYCLE AN EPR/SUCTION STOP OR A LIQUID LINE SOLENOID VALVE. IF A LIQUID LINE SOLENOID IS USED, IT MUST BE LOCATED AT THE CASE.

DEFROST SETTING:			
NO. OF PERIODS	TERMINATION	FAIL SAFE	MODEL
1/24 HOURS	TIME	46 MINS.	S39SJ1/S35SJ1
1/24 HOURS	TIME	80 MINS.	S39S(F)1/S35S(F)1

PARTS LIST S39S(J)1/S35S(J)1		
DESCRIPTION	8'	12'
INTERIOR TOP LIGHTS BALLAST (GE 8G10-22W) (GE 8G10-63)	(1) 10D10-038	(1) 10D10-038 (1) 10D10-037
LAMPS (F40T12-N)	(2) 10A10-056	(3) 10A10-056
SHELF LIGHTS BALLAST (ROBERTSON S40B) LAMPS (F30T8-N)	(1) 10D10-012 (1) 10A10-017	(1) 10D10-012 (1) 10A10-017
FAN MOTOR (FORCED AIR ONLY) (GE 5KSMS1AG)	(2) 09A10-017	(3) 09A10-017
FAN BLADE (FORCED AIR ONLY) ( )	(2) 09B10-013	(3) 09B10-013
LOWER FRONT PANEL (PTD)	(1) 51A12-208	(1) 51A14-160
KICKPLATE (BRIGHT)	(1) 55A32-389	(1) 55A32-390
END KICKPLATE (BRIGHT) LEFT HAND RIGHT HAND	(1) 55A32-398 (1) 55A32-400	(1) 55A32-398 (1) 55A32-400
OUTSIDE TOP (BRUSHED)	(1) 55F12-145	(1) 55F14-124
OUTSIDE TOP (BRIGHT)	(1) 55F12-146	(1) 55F14-125
LEFT HAND INSIDE DOOR	(2) 18F10-144	(3) 18F10-144
RIGHT HAND OUTSIDE DOOR	(2) 18F10-145	(3) 18F10-145
FRONT GLASS - 25"	(1) 14D11-047	(1) 14D11-048
FRONT GLASS - 29"	(1) 14D11-045	(1) 14D11-046

## RECOMMENDED PIPING PRACTICES FOR KYSOR//WARREN CASES

Proper size refrigeration lines are essential to good refrigeration performance. Suction lines are more critical than liquid or discharge lines. Oversized suction lines may prevent proper oil return to the compressor. Undersized lines can rob refrigeration capacity and increase operating cost. Consult the technical manual or legend sheet for proper line sizes.

Refrigeration lines in cases in line-ups can be reduced. However, the lines should be no smaller than the main trunk lines in at least 1/3 of the cases and no smaller than one size above the case lines to the last case. Reductions should not exceed one line size per case. It is preferred to bring the main trunk lines in at the center of line-up. Liquid lines on systems on hot gas defrost must be increased one line size above the main trunk line for the entire line-up. Individual feed lines should be at the bottom of the liquid header.

Do not run refrigeration lines from one system through cases on another system. Use dry nitrogen in lines during the brazing to prevent scaling and oxidation.

Insulate suction lines from the cases to the compressor with 3/4" wall thickness Armaflex or equal on low temperature cases to provide maximum of 65 degree superheated gas back to the compressor and prevent condensation in exposed areas. Insulate suction lines on medium temperature cases with 1/2" thick insulation in exposed areas to prevent condensate droppage.

Suction and liquid lines should never be taped or soldered together. Adequate heat exchanger is provided in the case.

Refrigeration lines should never be placed in the ground unless they are protected against moisture and electrolysis attack.

Always slope suction lines down toward the compressor, 1/2" each 10'. Do not leave dips in the line that would trap oil.

Provide "P" traps at the bottom of suction line risers, 4' or longer. Use a double "P" trap for each 20' of risers. "P" traps should be the same size as the horizontal line. Consult the technical manual or legend sheet for proper size risers.

Use long radius ells and avoid 45 degree ells.

Provide expansion loops in suction lines on systems on hot gas defrost. See Engineering Bulletin #85-204-3 for detail.

Strap and support tubing to prevent excessive line vibration and noise.

Brazing of copper should be with a minimum of 10% silver. Copper to brass or copper to steel should be with 45% silver.

Avoid the use of "bull head" tees in suction lines. An example is where suction gas enters both ends of the tee and exits the center. This can cause a substantial increase in pressure drop in the suction lines.

When connecting more than one suction line to the main trunk line, connect each branch line with an inverted trap.

IMPROPER LIQUID LINE PIPING FOR MULTICASE HOT GAS DEFROST

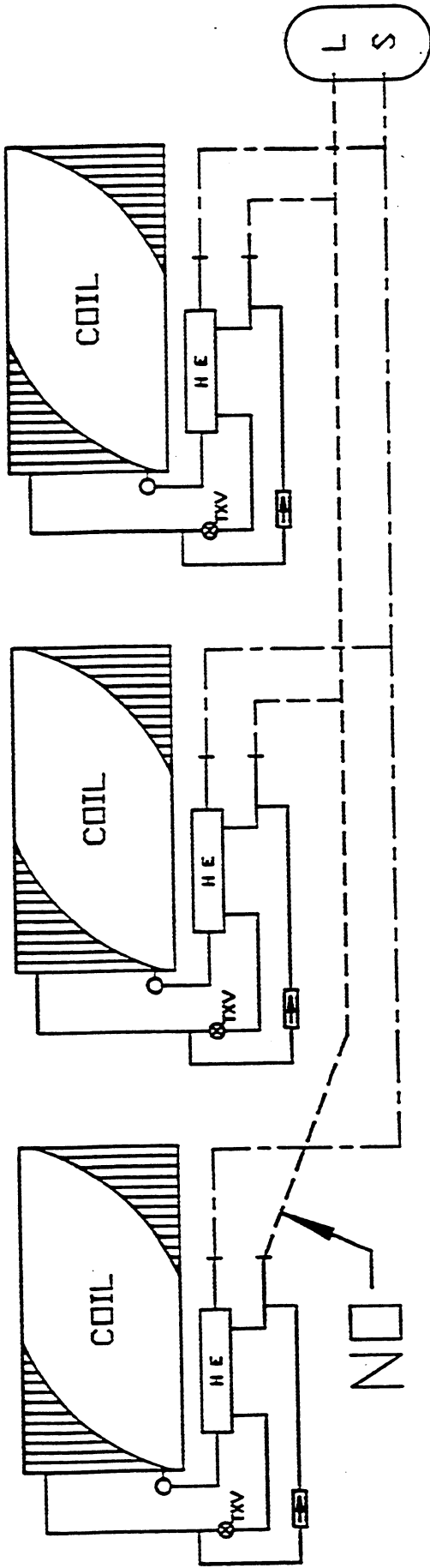

PROPER LIQUID LINE PIPING FOR MULTICASE HOT GAS DEFROST

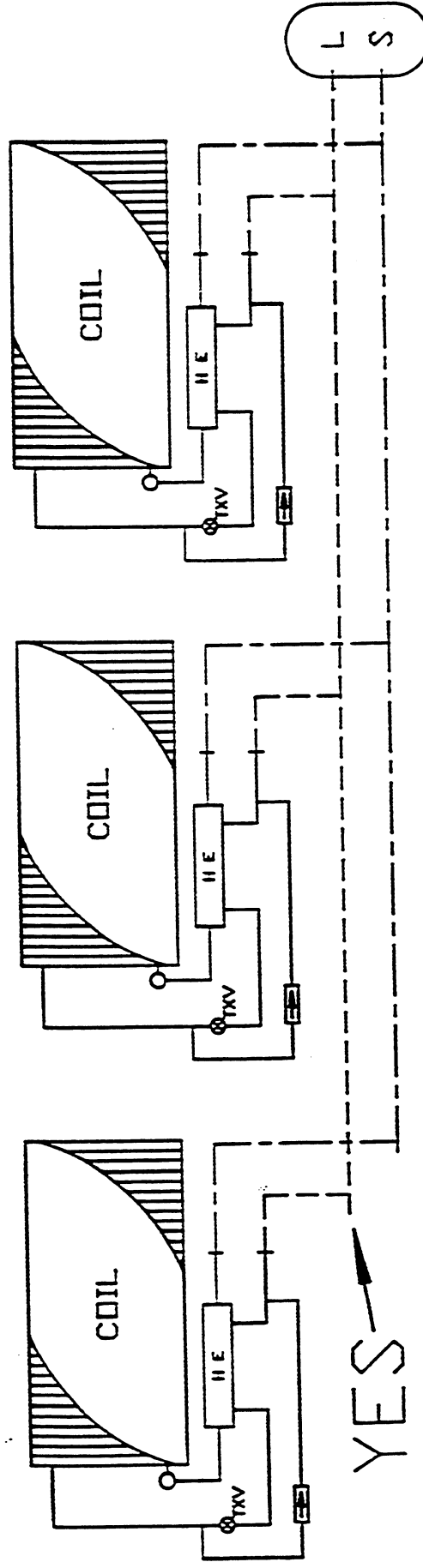

----- Field Piping - LIQUID  
 ----- Field Piping - SUCTION

	S35SJ1	S39SJ1
A	25.063	29.063
B	26.343	22.593

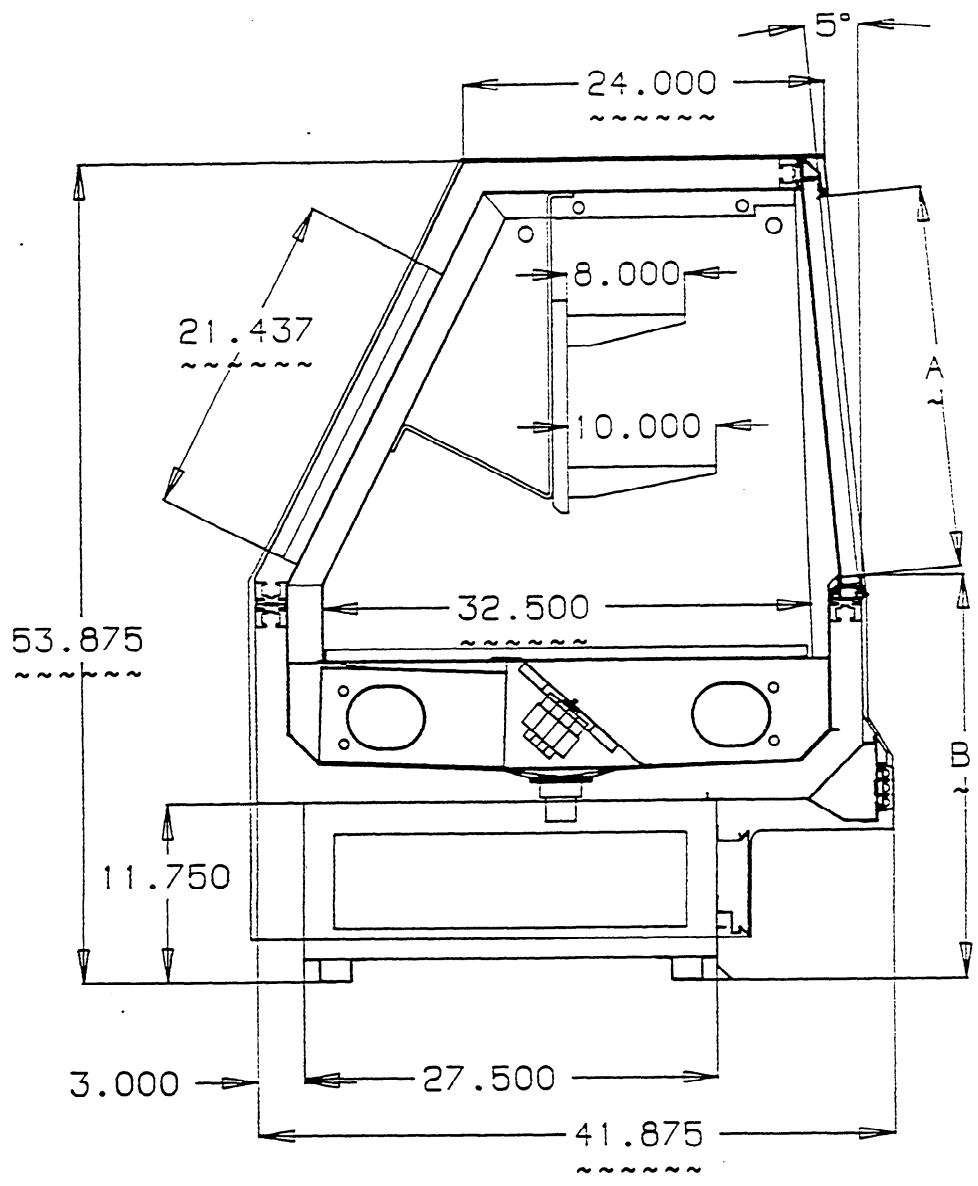

S35SJ1 / S39SJ1

1 1/2" (3.8 CM)

144 1/2" - (367.0 CM)  
96 3/8" - (244.8 CM)

1 1/2" (3.8 CM)

REAR OF CASE

12" (30.5 CM)

24" (61.0 CM)

24" (61.0 CM)

12" (30.5 CM)

41 7/8" (106.4 CM)

18" (45.7 CM)

13

ELEC. STUB-UP

REFRIG. STUB-UP

CASE WASTE OUTLET

ALTERNATE FLOOR DRAIN LOCATIONS

LETTER	REVISION		DATE	BY
DATE 5 APR 89	L A Y O U T	S39(S)(J)(V)1 S35(S)(J)1 PLAN VIEW		
SCALE 1/2"=12"				
DRAWN BY JESSE				
SHEET	KYSOR // WARREN		DRAWING NUMBER	PLAN VIEW

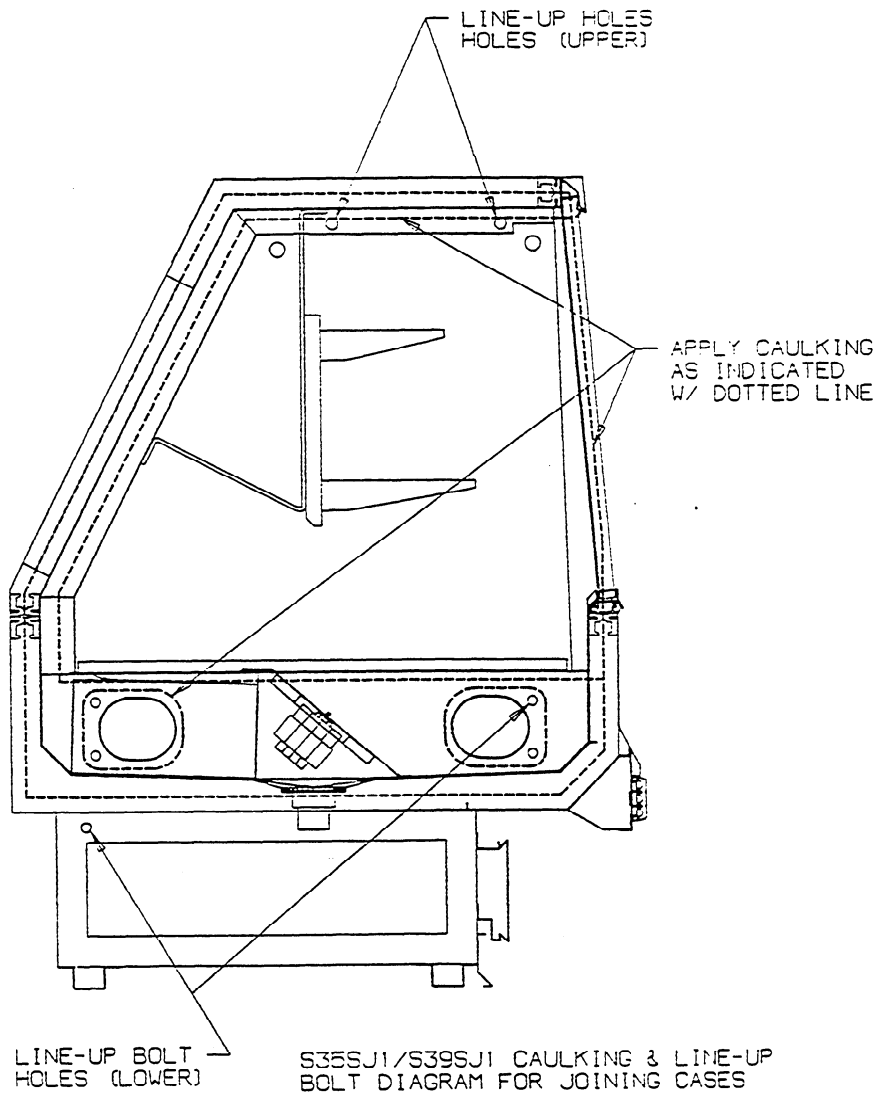

	S35S1	S39S1
A	25 1/16"	29 1/16"
B	26 11/32"	22 19/32"

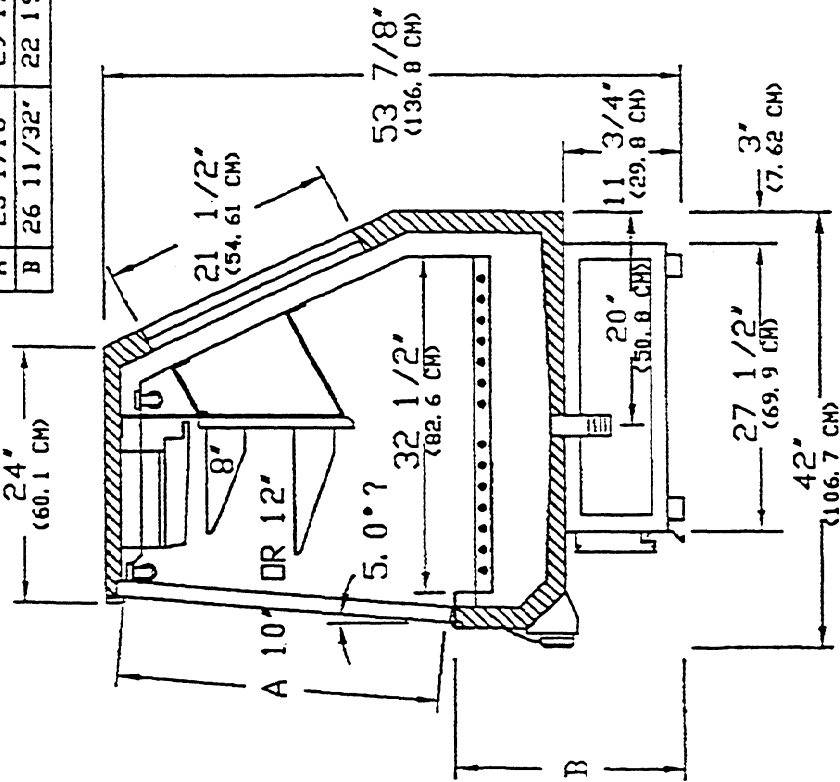

REAR OF CASE

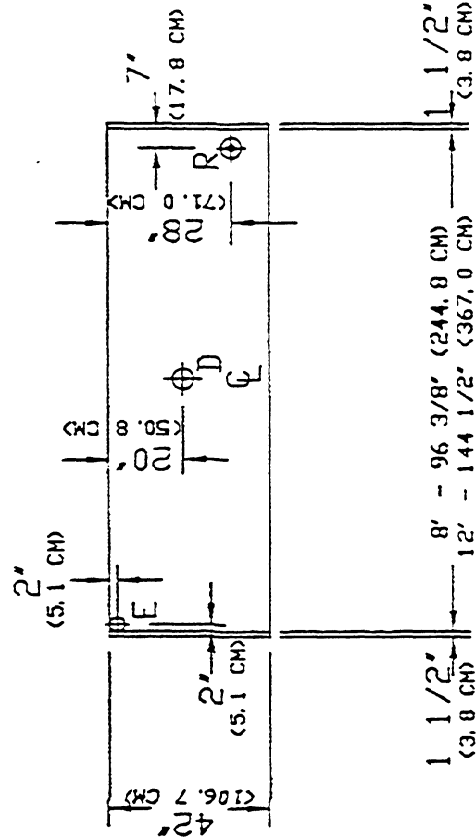

S39S1



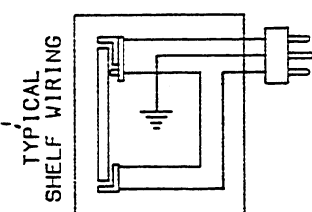
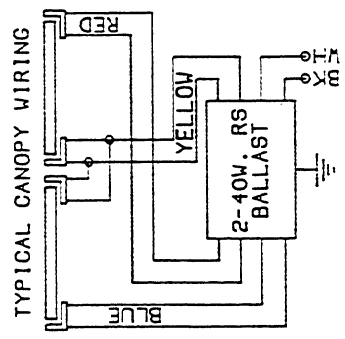

OPT. SHELF LIGHT RECEPTACLE •

WIRING-S35S (J) I,  
S39S (J) I, S39V (J) I-8ft.  
BEN TOOFBS 1/20/69  
KYSOR/WARREN PB-30059

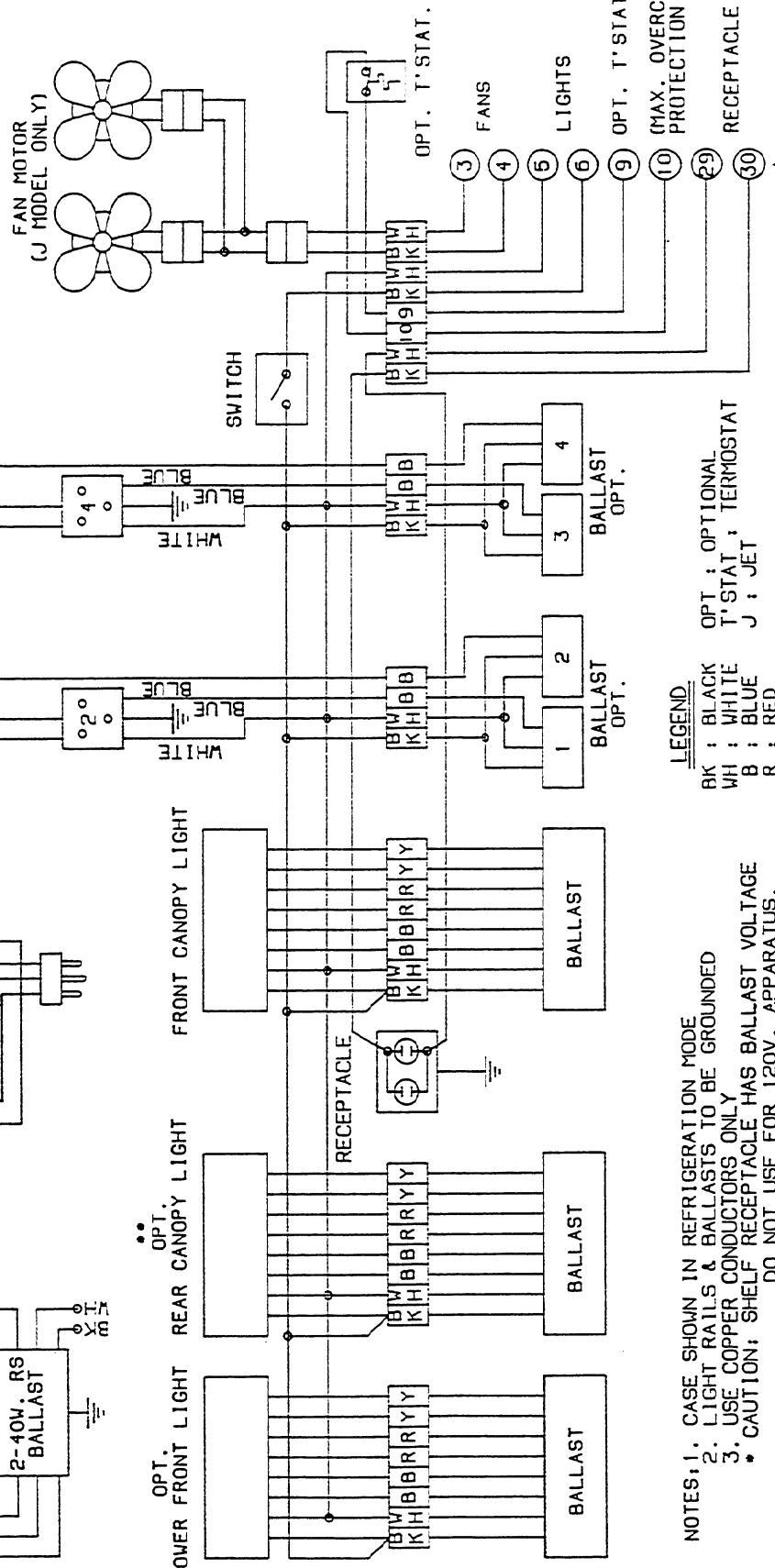

LEGEND.  
BK : BLACK  
WH : WHITE  
B : BLUE  
R : RED

- NOTES: 1. CASE SHOWN IN REFRIGERATION MODE  
2. LIGHT RAILS & BALLASTS TO BE GROUNDED  
3. USE COPPER CONDUCTORS ONLY  
• CAUTION: SHELF RECEPTACLE HAS BALLAST VOLTAGE DO NOT USE FOR 120V. APPARATUS.  
5. •• NOT AVAILABLE ON S39V1 MODEL

K/W PP# 31C10-420

115 VAC. LINE

WIRING-8366 (J) 1,	
8396 (J) 1, 839V (J) 1-12ft.	
BEH 10088	1/20/86
KYSOR/HARREN	PB-30058

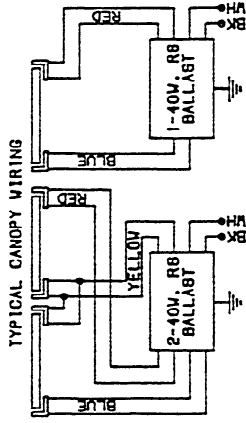
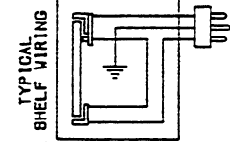
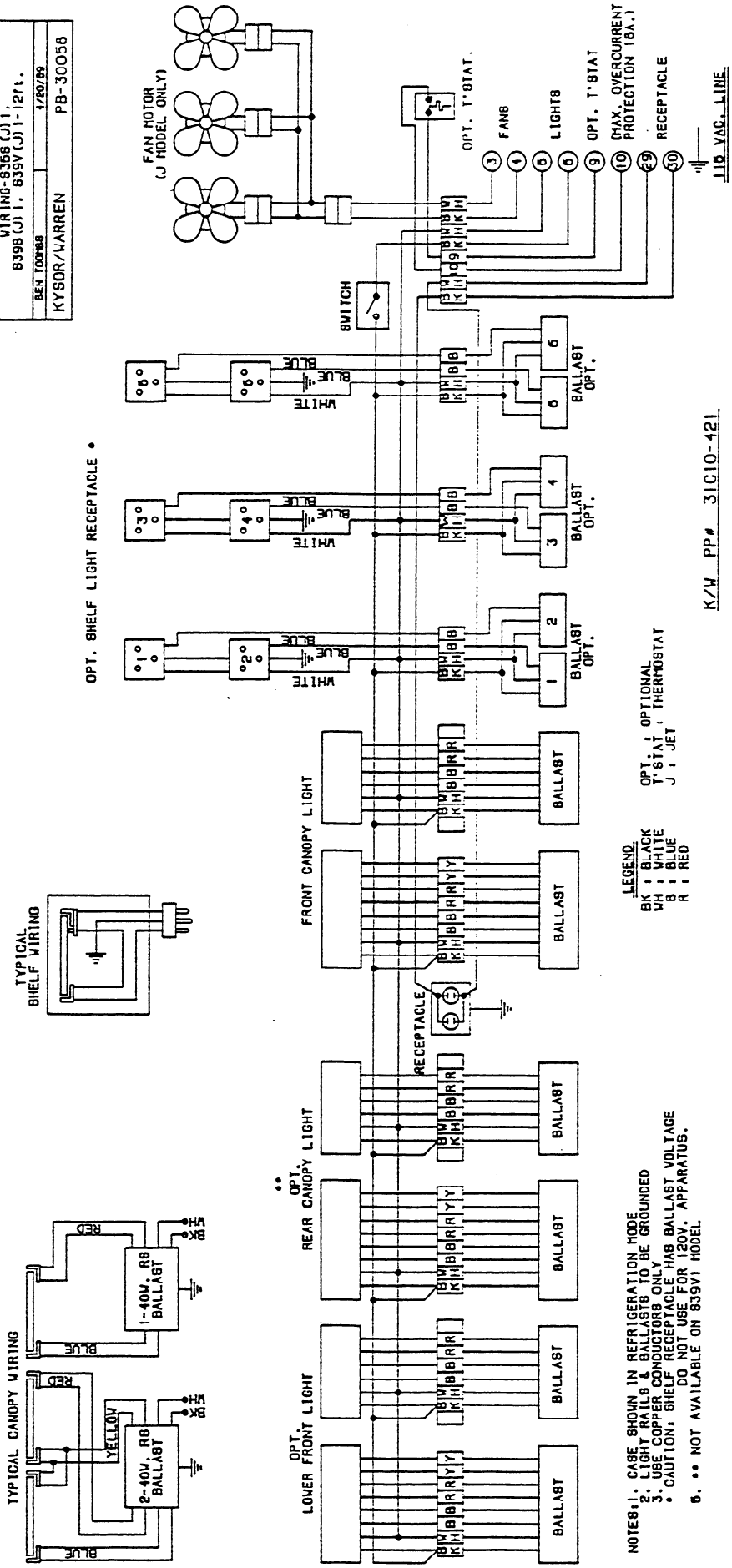

OPT. SHELF LIGHT RECEPTACLE •

LEGEND  
 BK : BLACK  
 WH : WHITE  
 B : BLUE  
 R : RED

NOTE 1. CABE SHOWN IN REFRIGERATION MODE  
 2. LIGHT BALLASTS & BALLASTS TO BE GROUNDED  
 3. USE COPPER WIRE IN RECEPTACLE HAS BALLAST VOLTAGE  
 • CAUTION, SHEDS DO NOT USE FOR 20V. APPARATUS.  
 5. •• NOT AVAILABLE ON 839V1 MODEL

K/W PP# 31C10-421

IN THE CONSTANT EFFORT TO IMPROVE OUR PRODUCTS, WE RESERVE THE RIGHT TO CHANGE AT ANY TIME SPECIFICATIONS, DESIGN, OR PRICES WITHOUT INCURRING OBLIGATION.

# KYSOR // WARREN

DIVISION OF KYSOR INDUSTRIAL CORPORATION

P.O. Box C  
1600 Industrial Blvd.  
Conyers, Georgia 30207  
770-483-5600

## ONE-YEAR WARRANTY

KYSOR/WARREN warrants to the original purchaser this new equipment and all parts thereof, to be free from defects in material and workmanship under normal use and service. If any part or parts of the equipment should prove defective during the period of one year from installation date (not to exceed one year and thirty days from the date of original shipment from the factory), KYSOR/WARREN hereby guarantees to replace or repair, without charge (F.O.B. CONYERS, GEORGIA), such part or parts as prove defective, and which KYSOR/WARREN's examination discloses to its satisfaction to be thus defective, with a new or functionally operative part. The liability of KYSOR/WARREN under this warranty shall be limited to claims made by the original purchaser to KYSOR/WARREN or its local distributor within the warranty period.

**GLAZING:** Glass is not guaranteed against breakage. If this refrigerator is equipped with a glazing assembly carrying the manufacturer's brand name (Thermopane, Twindow, etc.), the manufacturer's glazing warranty in effect at the time of this shipment is extended to that assembly. It is void outside the continental United States.

THIS WARRANTY IS IN LIEU OF ALL OTHER WARRANTIES, EXPRESSED, IMPLIED OR STATUTORY, INCLUDING, BUT NOT LIMITED TO ANY WARRANTY OF MERCHANTABILITY OR FITNESS, AND ALL OTHER OBLIGATIONS OR LIABILITIES OF KYSOR/WARREN.

THIS WARRANTY SHALL NOT APPLY:

1. To the condensing unit used with refrigerated equipment unless same was sold and shipped by KYSOR/WARREN.
2. When this equipment or any part thereof is damaged by fire, flood, act of God, or when the original model and serial-number plate has been altered, defaced, or removed.
3. When this equipment or any part thereof is subject to accident, alteration, abuse, misuse, tampering, operation on low or improper voltages, or is put to a use other than recommended by KYSOR/WARREN.
4. When this equipment or any part thereof is damaged, or when operation is impaired, due to failure to follow installation manual (improper installation is the responsibility of the installer).
5. Outside the continental United States.
6. To labor cost for replacement of parts, or for freight or shipping expenses.
7. If the Warranty holder fails to comply with all the provisions, terms and conditions of this Warranty.

Parts replaced under this Warranty are warranted only through the remainder of the original Warranty. KYSOR/WARREN may, at its option and in its discretion, elect to honor this Warranty and to disregard the original purchaser's noncompliance with any of the provisions, terms and conditions of this Warranty.

THIS WARRANTY DOES NOT COVER CONSEQUENTIAL DAMAGES.

KYSOR/WARREN shall not be liable under any circumstances for any consequential damages, including loss of profits, additional labor costs, loss of refrigerant or food products, or injury to person or property caused by defective material or parts or for any delay in the performance of this Warranty due to causes beyond its control. The foregoing shall constitute the sole and exclusive remedy of any purchaser and the sole and exclusive liability of KYSOR/WARREN in connection with this product.