

Part Number: 31E11009
Date Revised: 10/17/05

KYSOR/WARREN

5201 Transport Boulevard
Columbus, GA. 31907
706-568-1514



Installation & Operation Manual

VRHB 950 (Blower/GRAV)





IMPORTANT – KEEP IN STORE FOR FUTURE USE

Table of Contents

Introductions – General Information	4	Wiring Diagram	16
Case Description	4	Refrigeration Piping and Dehydration	17
Receiving/Shipping Damage/Lost Items		Recommended Piping Instructions	
.....	4	17
Refrigerant	5	Expansion Valve and Superheat	18
Plan View and Cross Section.....	5	Operation.....	19
Case Data	6	Loading	19
Case Installation.....	7	Normal Operation	20
Preparation	7	Ambient Air Fans.....	20
Installation.....	8	Cleaning	21
Unpacking	8	Parts List And Drawings.....	22
Installing First Case	8	Warranty	24
Leveling Cases	9	Parts Warranty Policy	24
Installing Subsequent Cases.....	10	New Equipment Parts Shortages and	
Joining Instructions.....	10	Defects	24
Installation of Trim, Caps, & Shelves		Parts Ordering Procedure.....	24
.....	12	Return Authorization Procedure	25
Waste Outlet (Drain Pipe) Description		One-Year Warranty.....	25
and Location.....	12		
Drain Strainer.....	13		
Installation of Mount Scale Stands			
.....	13		
Electrical Connections – General.....	15		

Introductions – General Information

This manual has been prepared for our customers and the personnel involved in setting up and maintaining our cases.

Icon Key	
	Caution
	Special Note
	Warning

The Kysor//Warren case is designed to provide years of trouble free service. The Kysor//Warren 3200 Series VRHB 950RP service cases are designed to merchandise meat and seafood products. These cases should be installed and operated according to the instructions contained in this manual to insure proper performance. They are designed for display of products in an air-conditioned store where temperature and humidity are maintained at a maximum of 75°F dry-bulb temperature and 55% relative humidity.

Case Description

Model	Description
VRHB 950RP	Service Meat and Seafood Case, Total Height 50.00”, Multi-Level Storage, Lower Deck Pan 34” Deep, Total Case Depth of 48” (Blower/GRAV combo)

Receiving/Shipping Damage/Lost Items

All equipment should be examined for shipping damage before and during unloading. If there is any damage, the carrier should be notified immediately and an inspection requested. The delivery receipt must be noted that the equipment was received damaged. If damage is of a concealed nature, you must contact the carrier within three (3) days following delivery. A claim must be filed with the carrier by the consignee for all damages.



Note: All claims for shortages must be within 10 days after receipt of shipment.

Refrigerant

A variety of refrigerants can be used in the Kysor//Warren cases provided the correct expansion valve is equipped with the case when ordered (i.e., R-22 required for the end user requires specifying the correct expansion valve for R-22 refrigerant when the order is placed). Multiple expansion valves are available, dependant on end user refrigerant requirements. Expansion valves are supplied for the refrigerant specified on the original sales order.

In addition, cases can be modified in the field to allow changing the type of refrigerant used. This requires changing the expansion valve and distributor orifice that is currently equipped in the case. Contact your Kysor//Warren Service Representative for additional information.

Plan View and Cross Section

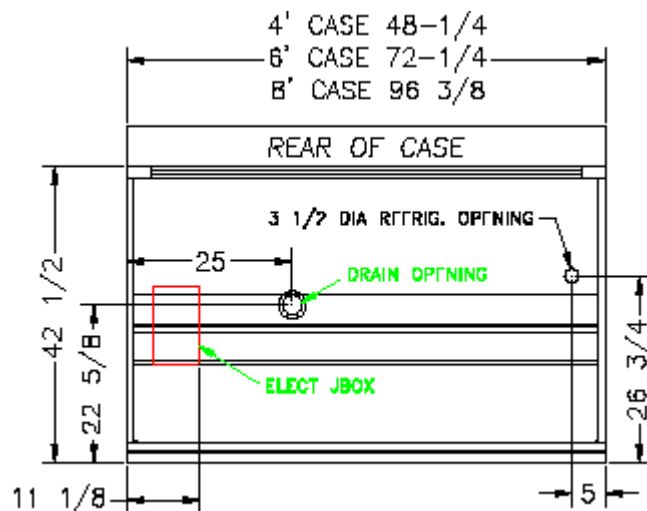
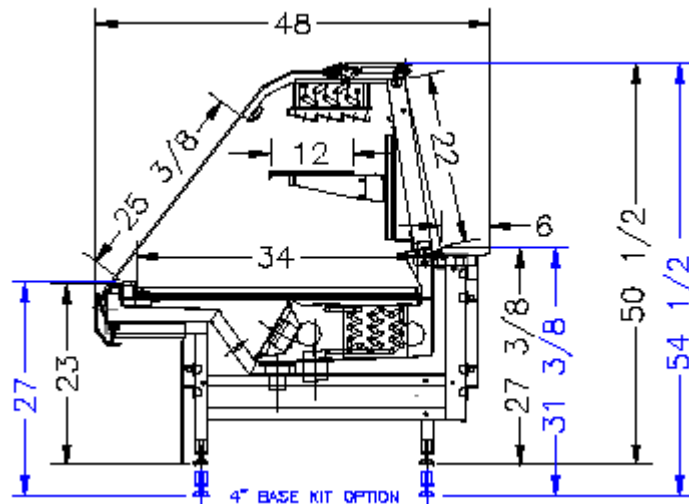

Case Data

VRHB 950

Defrost	Per Day	Fail Safe	Termination
Hot Gas	2Hrs	20 Min.	48°F
Off Cycle	2Hrs	65 Min.	48°F

Capacities	4'	6'	8'
Square Footage	11.45	17.06	22.76
Cubic Capacity	13.89	20.84	27.75
Dimensions			
Overall Length (w/o ends)	48-1/4"	72-1/4"	96-3/8"
Available Ends listed below			
Unit Data			
Anti-Sweat Amps	0.50	0.80	1.10
Fan Amps STD	1.40	2.35	2.35
Light Amps	0.24	0.47	0.47
Evaporator Temperature	10°F	10°F	10°F
Btu/Hr Requirements			
Btu Requirements (Parallel)	3,400	5,100	6,800
Btu Requirements (Single)	3,672	5,508	7,344
Available Ends (thickness) Dimensions given per end			
Standard Foam	1-1/2"	1-1/2"	1-1/2"
Glass	3/8"	3/8"	3/8"
PVC	3/4"	3/4"	3/4"

* Add @ 19 But/Hr/Ft per row of lighted shelves

Unit Model	Discharge Air Velocity (1 hour after defrost)	Discharge Air Temperature
VRHB	250 FPM (+/- 25)	24°F



Note: Temperature is measured in discharge air. Defrost frequency is at design conditions. Higher temperature or humidity may require more defrost and longer fail-safes. Maximum 75 °F and 55% humidity continuously is recommended for the efficiency of your case. Off-cycle defrost is the recommended defrost for all Q case models. Electric defrost is not recommended on Q case models.

Refer to www.kysorwarren.com for other electrical data and information.

Case Installation

These display cases may be installed individually or in a continuous line up consisting of several 4', 6', 8' and 12' sections using a joint kit. A plexi-glass divider kit must be used between cases operating on different refrigeration systems. The divider will be factory installed if specified on order.

Preparation

Prepare the installation area as follows:

1. Clean area where case is to be installed.
2. Verify installation area is at least 15 feet from any outside entrances or heating and cooling outlets.
3. Ensure floor loading will support the case and the case contents.
4. Ensure proper AC power is available. Refer to case AC input requirements located in the electrical connections section of this manual.
5. Ensure location will allow connection to drain lines and the drain line, when installed, will meet the recommendations as set forth in the refrigeration piping and dehydration section of this manual.
6. Ensure expansion valve in case is the proper valve for the type of refrigerant used at the installation site.

Installation

The following instructions are provided for unpacking, moving, loading, and lifting the case prior to installation.



Note: READ ALL INSTRUCTIONS CAREFULLY BEFORE BEGINNING INSTALLATION

Unpacking

1. Remove all shipping tape from lamps and ensure that all lamp ends are snapped in place.



WARNING! Use caution when removing the strapping in the following procedure as the shelves are very heavy and could fall causing personal injury or equipment damage.

2. Ensure the evaporator cover is installed correctly with the deck pans installed.
3. Move the case into position, install, adjust superheat, and perform the operational checkout procedures following the instructions within this manual.



Caution: Be careful not to damage the factory-installed end while moving the case. Use the case lift points on the case to move it to the proper location.

Installing First Case

1. Ensure all preparation for installation, as outlined in the above paragraphs, have been fully complied with and are complete.
2. If multiple cases are to be installed, find the highest area of the floor to place the first case.
3. All cases must be located on a firmly based floor and leveled within plus or minus 1/16 in. Use adjustable feet to support and level the entire length of your case(s). All legs of the case must be properly adjusted and in contact with the floor.



(**NOTE:** See Leveling Cases section below.)

4. If multiple cases are to be installed, refer to the floor plan and install the first case in the line up by snapping a chalk line where the front and rear of the cases are to be located. Continue the chalk line if multiple cases are to be installed. The first case is typically the case that is at the highest area on the floor.

5. **Connect water drain line. Reference waste outlet (drip pipe) description and location procedure later in this chapter.**
6. **Connect input AC power. Reference electrical installation procedure later in this chapter.**
7. **Connect refrigerant lines. Reference procedure later in this chapter.**
8. Install all ends, caps, and trim per the applicable instructions contained in the Assembly chapter of this manual.
9. Remove shipping tape on fluorescent lamps and remove all other shipping material.
10. Refer to the operational start up procedures later in this manual. If multiple cases are to be installed, refer to the following paragraph for installing subsequent cases.
11. Remove shipping tape on fluorescent lamps and remove all other shipping material.
12. Refer to the operational start up procedures later in this manual. If multiple cases are to be installed, refer to the following paragraph for installing subsequent cases.

Leveling Cases

All cases must be located on a firmly based floor and leveled. Use adjustable legs to support and level the entire length of your case(s). All legs of the case must be properly adjusted and in contact with the floor. Cases must be level and fully supported along all planes to prevent the case from sagging in the middle and to allow for proper drainage. To properly level the case, perform the following:



Caution: It is important to properly level the case to prevent case damage from sagging and to allow for proper drainage. Remember, the case could be loaded with several thousand pounds of merchandise that will allow the case to sag if not properly supported.



Note: Perform the case leveling procedure prior to connecting the electrical, drains, or refrigeration lines.

1. Determine the highest area on the floor in the area where the case(s) are to be installed to determine where to set the first case. If only one case is to be installed, disregard this procedure.
2. Install first case into position over the high spot in the room or area (see instructions above.)

3. Level the first case. Use the adjustable legs to adjust the case until all legs are firmly on the floor and the case is level. Make sure the middle legs are also fully supporting the case. To ensure the case is properly leveled, check the case first from side to side, middle, and then plum the case up and down. It may be necessary to lift the case on its lift points using a pry bar (i.e., Johnson bar).
4. Repeat procedure for all subsequent cases in the line up.

Installing Subsequent Cases

If additional cases are to be installed, follow the same procedures as described in the installing first case procedure (above), except the following:

1. Ensure all case expansion valves are correct.
2. Do not install electrical, drain lines, or refrigerant lines until all the cases have been set/placed into position.
3. Do not install case trim, ends, or caps until all cases have been set into position and properly joined.
4. Before lining up cases using the front and rear edges as a baseline, inspect refrigeration lines, electrical connections and controls to insure cases are in proper line up and are in proper sequence.
5. Move cases as near their permanent location as possible before removing shipping braces, skids or rollers. Note: All cases are factory numbered with line up and position numbers.

Make sure that cases are installed in order (line up sticker found on the front of each case).

6. Remove skids and shipping braces. Install approximately a 5/16" bead of sealer at one end of case as noted by a phantom line on cross-section.
7. Move cases as close together as possible and level by using the adjustable feet. Refer to the leveling cases procedure in the following text for the proper adjustment procedure. **CASES MUST BE LEVELED FROM FRONT TO BACK AND END-TO-END AND SUPPORTED CONTINUOUSLY AS NEEDED.** ( NOTE: See Leveling Cases section above.)
8. Remove shipping tape on fluorescent lamps and remove all other shipping material.
9. Refer to the operational start up procedures later in this manual.

Joining Instructions

Two or more cases of like models can be joined together to form a continuous line up. Before lining up cases, inspect refrigeration lines, electrical connections and controls to insure cases are in the proper line-up and are in the proper sequence. Reference and

become familiar with the below figure, and then join the cases using the instructions that follow.

Line Up Bolt Holes on Side of Cases

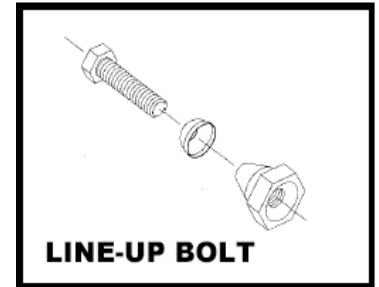
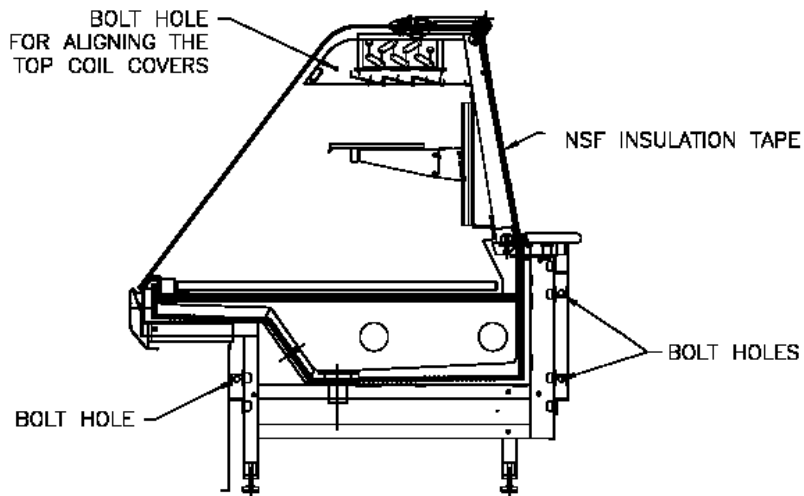

1. Remove access covers over line up holes and insert the small line up bolts (Figure 3-1) in the end frame in the bolt hole pattern identified in Figure 3-2. Place the special T-nut washer on the 3/8" machine bolt with the hollow section away from the bolt head. Tighten the 3/8" bolts with nut washer into the T-nuts alternately until cases are pulled up tight and the joint is completely sealed. (Reasonable care should be exercised in this procedure to prevent end frame distortion.) Assist pulling case up tight by bumping from opposite end of case or by using pry bar.
2. Inspect joint for proper air and watertight seal inside and outside the case.
3. Replace line up access cover plugs and plates.



Note: Most case trim can and should be installed immediately after cases are lined up. Where possible, install all trim immediately so it will not be lost. The trim that cannot be installed immediately should be stored in a safe place until refrigeration and electrical work is done.

Installation of Trim, Caps, & Shelves

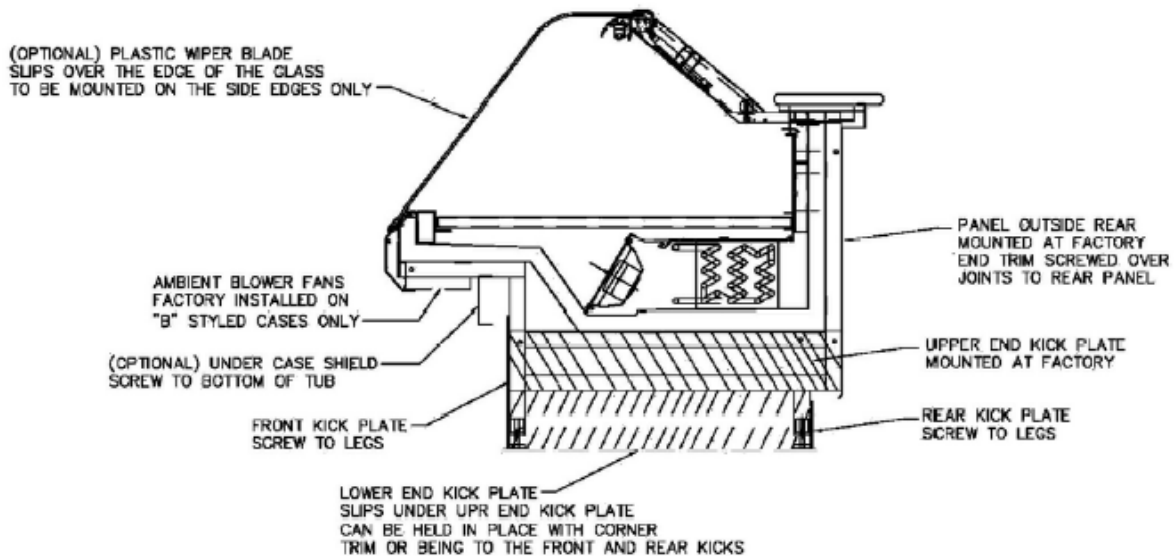

Waste Outlet (Drain Pipe) Description and Location

These cases are equipped with 1 ½" M-NPT waste outlet connection. The water seal trap is shipped loose for field installation. Improperly installed drain pipes (which is also the waste outlet) can seriously affect the operation of this case and result in increased maintenance costs. The following text and figures provide general rules for drain pipe installation.

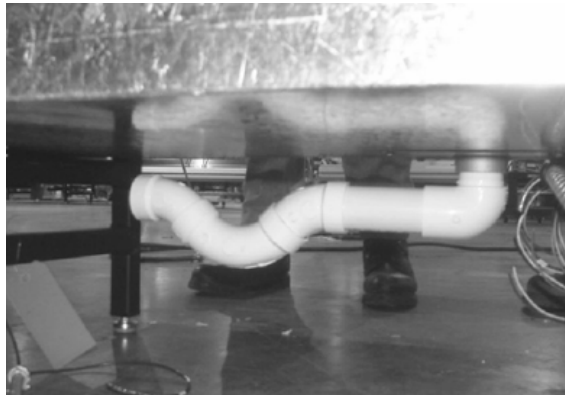

The drain pipe is installed on the outside-bottom of the case.

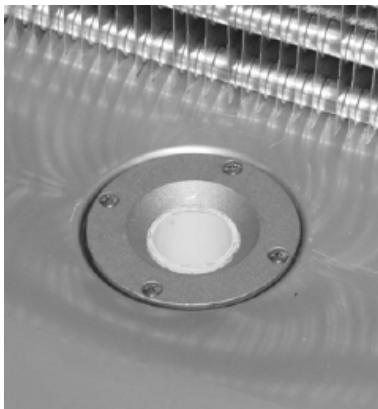

TRAP MUST BE INSTALLED

1. Never use a double trap.
2. Always provide as much fall as possible in drain pipe. (1" fall for each 4' of drain pipe.)
3. Avoid long runs in drain pipe, which makes it impossible to provide maximum fall in pipe.

4. Provide a drip space between drain pipe and floor drain or sewer connection.
5. Do not allow drain pipe to come in contact with uninsulated suction lines. If touching, the condensation in your case will freeze.

Drain Strainer

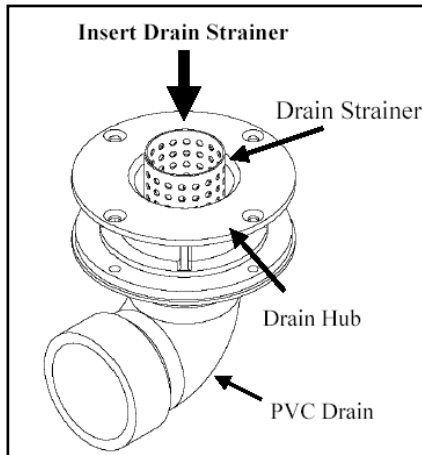

•**Purpose:** Keep debris or any foreign objects from entering the PVC drain which could cause blockage.

•**Installation:** Insert into drain until drain strainer stops – it will not be flush. Strainer will exceed hub by 1". DO NOT flatten drain strainer



Note: 1 1/2" Drain Pipe

Installation of Mount Scale Stands

Scale stands are optional, available in various sizes and can be mounted flush to the case or post mounted. Below are instructions with drawings for cases that may be equipped with scale stands.



WARNING! Always disconnect the electrical power at the main disconnect when servicing or replacing the scale stands. Failure to disconnect the electrical power may result in personal injury or death.

Remove the mounting screws on the exterior rear panel and lower the panel floor allowing panel to rest against rear of the case. Place the post in the desired position and check to see if there will be interference with the case hardware below the board when trying to drill the bolt through holes (for better support mount near the work board support brackets). Once the location is selected mark the bolt holes positions on the work board and drill. See drawing for the proper bolt and screw placements. Recommend placing the scale board on the work board, mark the holes and pre-drill for the screws also.

VRHB

2-3/4" MINIMUM DISTANCE
FROM THE GLASS CLAMP
VERIFY CLEARANCE BY COMPLETELY
OPENING THE GLASS

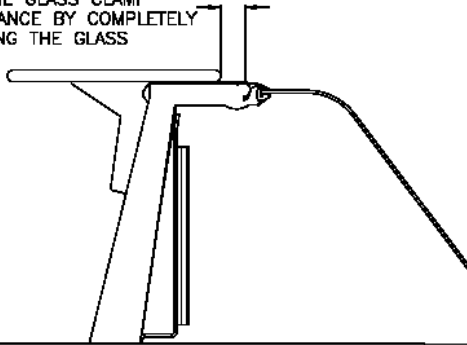

CENTER STRUT MOUNTING

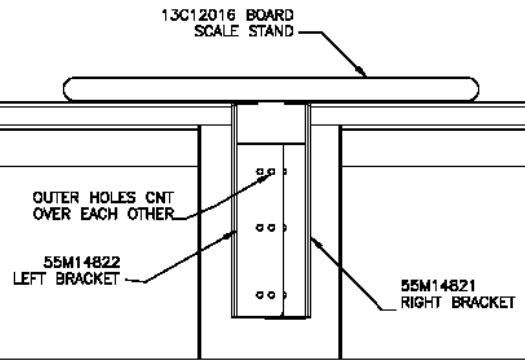

CASE JOINT MOUNTING

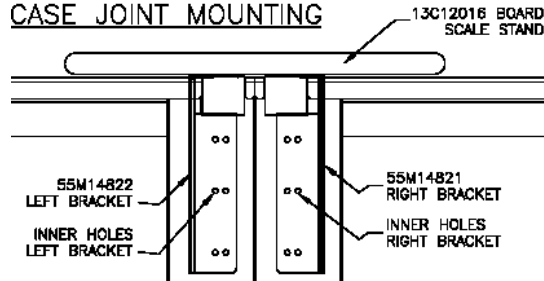

FLUSH MOUNT SCALE STAND MOUNTING INSTRUCTIONS:
FOR CENTER STRUTS MOUNTS THE TWO BRACKETS SHOULD OVER LAP EACH OTHER. THE MOUNTING OUTER MOST HOLES SHOULD BE CENTERED OVER EACH OTHER AND CENTERED OVER THE VERTICAL STRUT ARM. TOP FLANGE AND CASE TOP SURFACE MUST BE FLUSH. FOR CASE TO CASE JOINT MOUNTING BRACKET FLANGES SHOULD POINT TOWARDS EACH OTHER. THE LEFT BRACKET SHOULD MOUNT TO THE LEFT HAND CASE AND SCREWED TO THE EXTRUDED STRUT ARM USING THE INSIDE HOLES ON THE BRACKET. INSURE THAT THE MOUNTING SCREWS WILL NOT DAMAGE THE TOP COIL PIPING THAT IS HOUSED WITHIN THE ALUMINUM COVER. THE RIGHT BRACKET SHOULD MOUNT TO THE RIGHT HAND CASE AND SCREWED TO THE EXTRUDED STRUT ARM USING THE INSIDE HOLES ON THE BRACKET. TOP FLANGE AND CASE TOP SURFACE MUST BE FLUSH.

Electrical Connections – General

All electrical connections are made in the electrical junction box (see figures below).

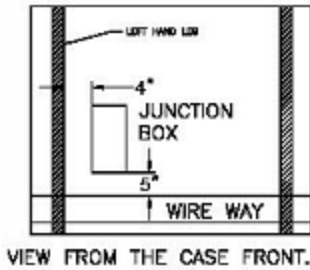

Picture of junction box under the case.

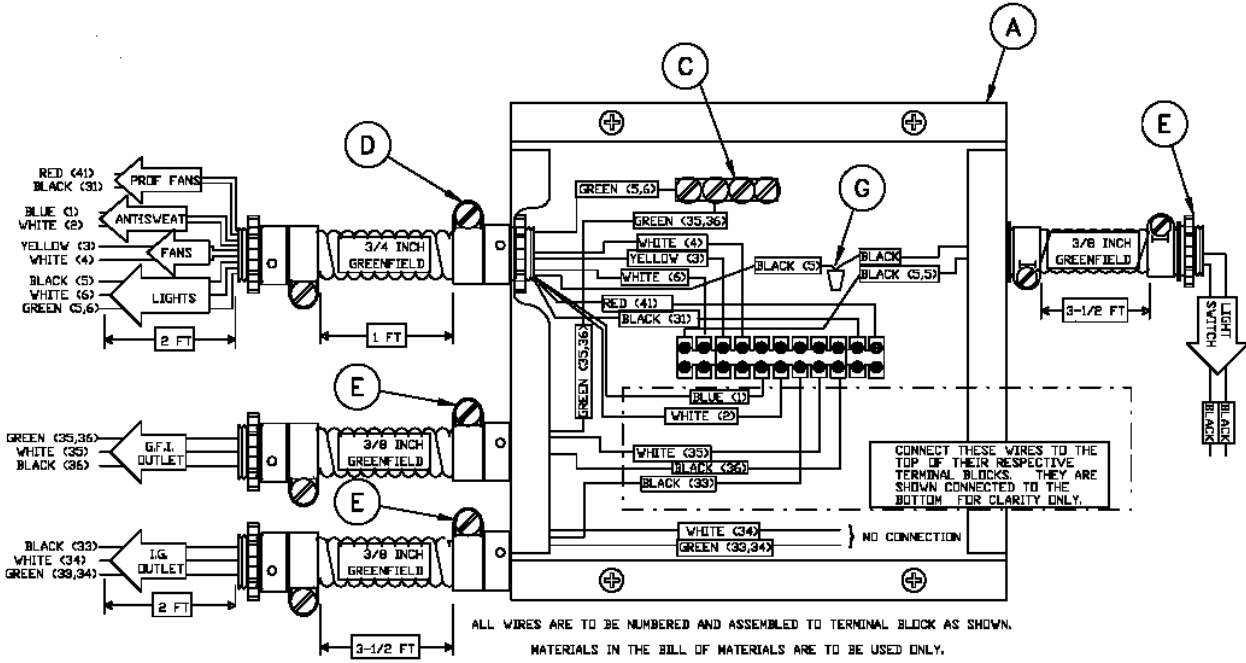
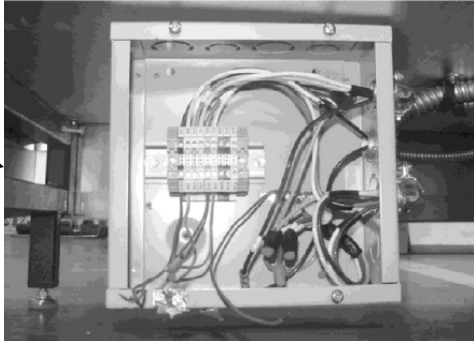

Wiring Diagram

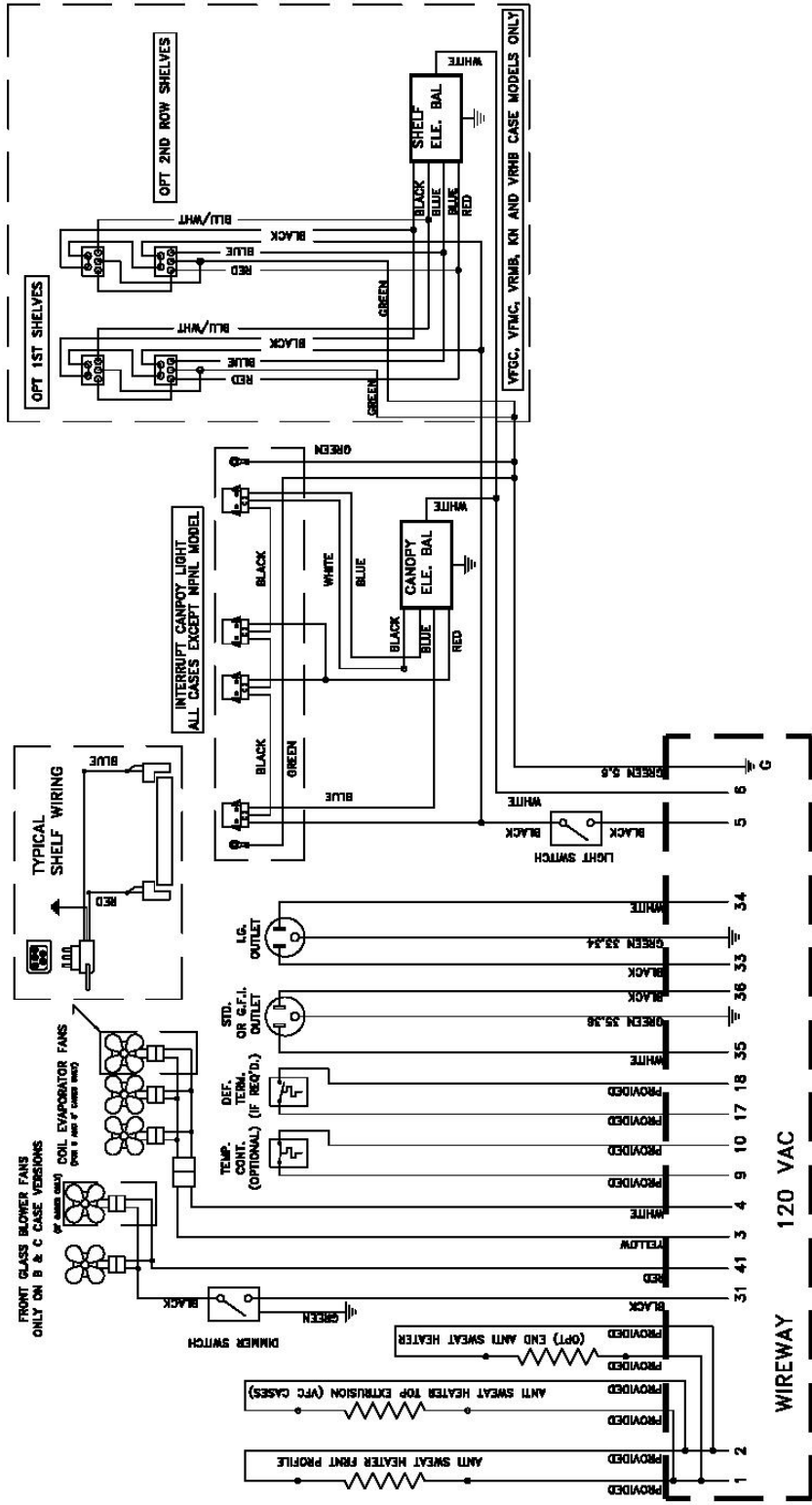

WIREWAY 120 VAC

VFC, VFM, YRMB, KN AND YRMB CASE MODELS ONLY

Refrigeration Piping and Dehydration

Recommended Piping Instructions

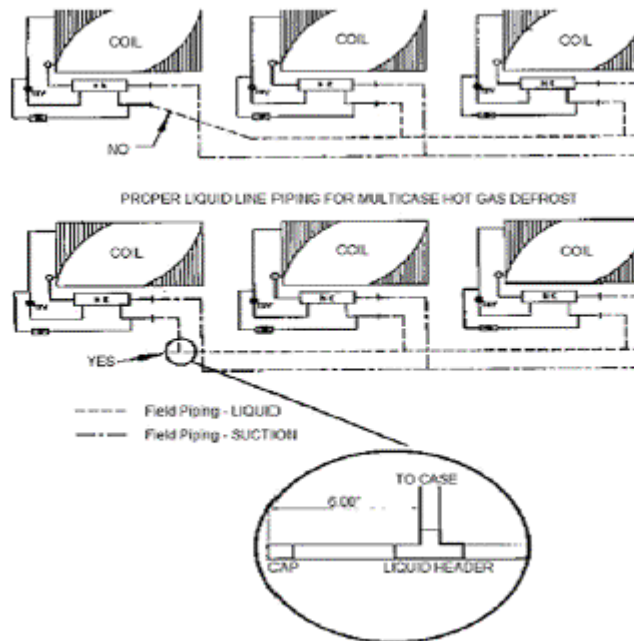

1. Proper size refrigeration lines are essential to good refrigeration performance. Suction lines are more critical than liquid or discharge lines. Oversized suction lines may prevent good oil return to the compressor. Undersized lines can rob refrigeration capacity and increase operating cost. Consult the technical manual or legend sheet for proper line sizes.
2. Refrigeration lines in cases in line-ups can be reduced. However, the lines should be no smaller than the main trunk lines in at least 1/3 of the cases and no smaller than one size above the case lines to the last case. Reductions should not exceed one line size per case. It is preferred to bring the main trunk lines in at the center of line-up. Liquid lines on systems on hot gas defrost must be increased one line size above the main trunk line for the entire line-up. Individual feed lines should be at the bottom of the liquid header. (See proper liquid line piping diagram.)
3. Do not run refrigeration lines from one system through cases on another system.
4. Use dry nitrogen in lines during brazing to prevent scaling and oxidation.
5. Insulate suction lines from the cases to the compressor with 3/4" wall thickness foam on low temperature cases to provide maximum of 65-degree super heated gas back to the compressor and prevent condensation in exposed areas. Insulate suction lines on medium temperature cases with 1/2" thick insulation in exposed areas to prevent condensate droppage.

6. Suction and liquid lines should never be taped or soldered together. Adequate heat exchanger is provided in the case. Kysor//Warren recommends use of heat exchanger in all medium and low temperature case that are not mechanically sub-cooled for proper operation.
7. Refrigeration lines should never be placed in the ground unless they are protected against moisture and electrolysis attack.
8. Always slope suction lines down toward the compressor, 2" each 10'. Do not leave dips in the line that would trap oil.
9. Provide P traps at the bottom of suction line risers, 4' or longer. Use a double P trap for each 20' of risers. P traps should be the same size as the horizontal line. Consult the technical manual or legend sheet for proper size risers.
10. Use long radius ells and avoid 45 degree ells.
11. Provide expansion loops in suction lines on systems on hot gas defrost. An expansion loop is required for each 100' of straight run.
12. Strap and support tubing to prevent excessive line vibration and noise.
13. Brazing of copper to copper should be with a minimum of 10% silver. Copper to brass or copper to steel should be with 45% silver.
14. Do not use bullhead tees in suction lines. An example is where suction gas enters both ends of the tee and exits the center. This can cause a substantial increase in pressure drop in the suction lines.
15. When connecting more than one suction line to a main trunk line, connect each branch with an inverted trap.

Suction line:

- a. Pitch in direction of flow.
- b. Suction lines should enter at the top of the branch line.
Maybe reduced by one size at one third of case run load and after the second third.
DO NOT reduce below the case suction line size.

Expansion Valve and Superheat



Caution: During service of this equipment, precautions should be taken to prevent loss of refrigerant to the atmosphere.

The expansion valve furnished with your case has been sized for maximum coil efficiency. To adjust superheat perform the following:

1. Place a thermocouple near the expansion valve bulb. Read the suction line pressure as near coil as possible. (If at the condensing case, estimate suction line loss at 2 PSIG).
2. Convert coil suction pressure to temperature. The difference between coil temperature and the thermocouple temperature is superheat. (Use average superheat when expansion valve is hunting).

3. Do not set superheat until cases have pulled down to operating temperature and never open or close the valve over ¼ turn between adjustments and allow 10 minutes or more between adjustments.
4. Superheat should be set to 6-8°F.
5. After the initial setting, the superheat should be rechecked when product is stocked and at designed temperature.

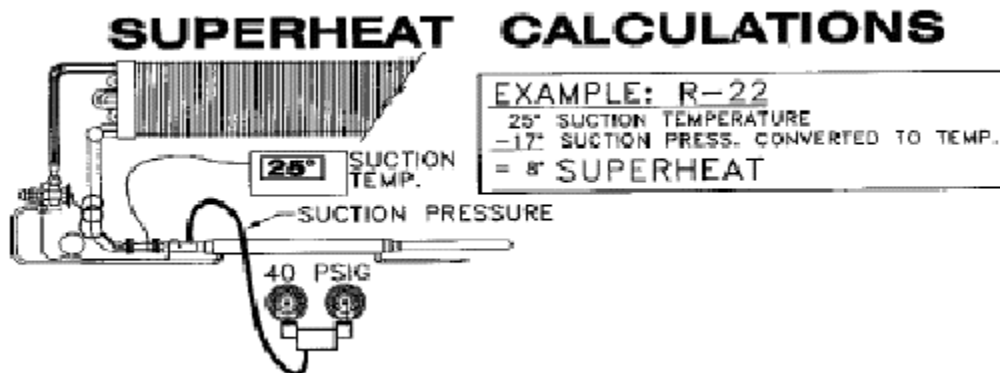

Operation

Loading

Merchandise should not be placed in the fixture until all controls have been adjusted and the case is at the proper temperature. **AT NO TIME SHOULD THE CASE BE STOCKED BEYOND THE LOAD LINE OR OVER THE FRONT EDGE OF ADJUSTABLE SHELVES.**

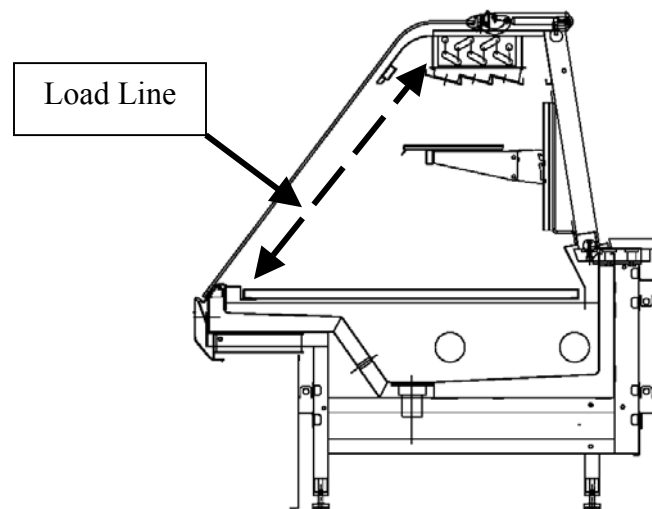

Do not place product in cases until it is at proper operating temperature. Air discharge and return flues must remain open and free of debris or obstruction at all times to provide

proper refrigeration and air current performance. Do not allow any product, signs, debris, etc. to block these grilles. Do not use any non-approved shelving, display racks or any accessory that could hamper air current performance.



Do not walk on top of the cases! This could result in damage to the case and serious personal injury could occur. These cases are not designed to support excessive external weight. Do not use top of cases for storage.

Normal Operation

1. Off-Cycle Defrost is standard on these models. The fans run continuously and defrost termination is by termination Klixon.
2. Hot Gas Defrost Models (optional for parallel compressor operation only) hot gas is routed through the suction line and evaporator coil. It exits the coil through a by-pass around the expansion valve and heat exchanger to return to the liquid line where the condensed liquid is used to feed the other cases on the same parallel case. The case fans continue to operate during defrost to warm up the drain pan and air ducts. The defrost cycle is time initiated and should be temperature terminated. (See case data information.)
3. Single Condensing Case Systems – A thermostat should be used to control case temperatures. The thermostat bulb should be mounted in the discharge air (see case data if your case is a single condensing case system).

Ambient Air Fans

Ambient air fans are in all VRMB, VRHB, VFGC and VFMC. The ambient air fan speeds can be adjusted by using the fan speed control switch. The ambient air fan adjustment is located in the front of the case behind the front profile (see below).

To control front glass condensation, the fan adjustment recommended position is mid-speed or 50%. Fans may be adjusted to a higher speed for store conditions above industry standard 55% relative humidity and 75 degree ambient.



NOTE: Settings above 50% fan speed will increase the fan noise level.

Ambient air fan adjustment (front glass).

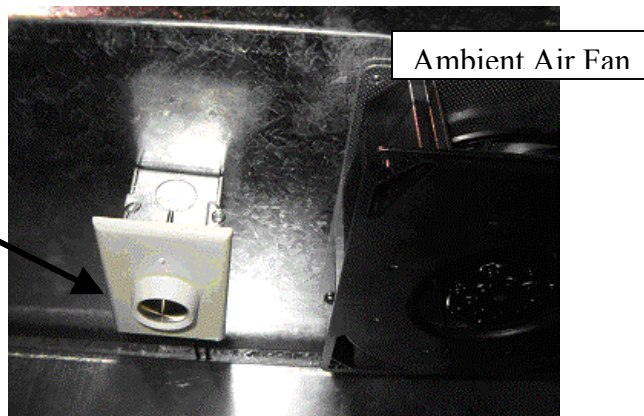

Cleaning

As a general rule, always use mild soap and water to wipe the case down. Special precautions must be taken when cleaning some components of the case.

Exterior surfaces should be cleaned with warm water and mild soap to protect and maintain the finish. **Do not use cleaners containing abrasive materials or ammonia, which will scratch or dull the finish.** The waste outlet should be flushed with water following each cleaning.

Interior surfaces may be cleaned with most mild soap formulas, ammonia based cleaners and sanitizing solutions with no harm to the surface.



WARNING! Always shut power off during the cleaning process. Cleaning the case with electrical power applied is a shock hazard that may cause serious injury or death.



WARNING! DO NOT USE HOT water on COLD glass surfaces. This could cause the glass to shatter and could result in personal injury. Glass fronts and ends should be warm before applying hot water.



Caution: The following could damage the case:

- Do not use solvent, oil or acidic-based cleaners on any interior surfaces as the surface may become damaged.
- Do not use abrasive cleaners and scouring pads as these will mar the finish.
- Never introduce water into the case faster than the waste outlet can release it.
- **DO NOT USE STEAM OR HIGH PRESSURE SYSTEMS TO CLEAN THE CASE, AS SEALS MAY BE BROKEN WHICH WILL CAUSE THE CASE TO LEAK.**

Shelves

Do not use a hose or submerge shelves in water. When cleaning lighted shelves, wipe down with a wet sponge or cloth so that water does not enter the light rails.

Parts List And Drawings

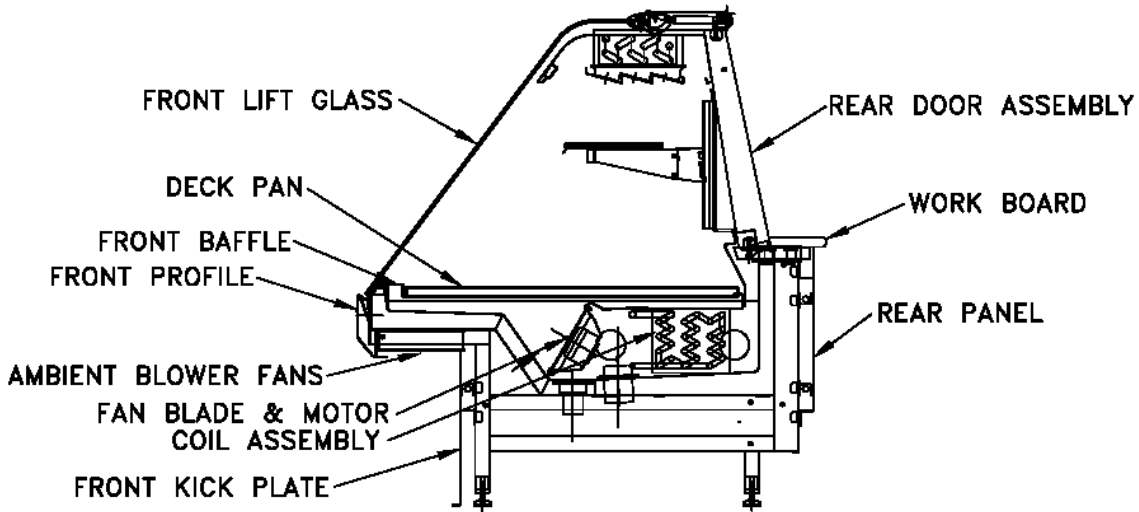

	VRHB-950-4' 97E10267	VRHB-950-6' 97E10268	VRHB-950-8' 97E11268
DESCRIPTION	4' PART #	8' PART #	8' PART #
FAN BLADE	09B10068	09B10068	09B10068
HARNES CANOPY LIGHTS	10M10356	10M10356	10M10356
CAP LAMPHOLDER	10B11108	10B11108	10B11108
ANTI SWEAT HEATER	10K10176	10K10176	10K10176
BALLAST 2 LAMP	10D10065	10D10065	10D10065
FRONT PROFILE	16A21091	16A21091	16A21091
TOP EVAP COIL	05A20252	05A20253	05A20254
BOTTOM EVAP COIL	05A20256	05A20261	05A20266
FRONT LIFT GLASS NON-GLARE	14A13016	14A13015	14A13016
BAFFLE FRONT	56B10175	56B10174	56B10173
FAN MOTOR	82D10151	82D10151	82D10151
DECK PAN	56J13046	56J13046	56J13046
MALE SHELF WIRE HARNESS	10M10260	10M10260	10M10260
FEMALE SHELF WIRE HARNESS	0.021081	0.021081	0.021081
PANEL OS REAR	55G18811	55G18810	55G18809
DOOR ASSEMBLY MIRROR GLS	14A10046	14A10044	14A10019
DOOR ASSEMBLY CLEAR GLS	14A10047	14A10045	14A10024



Note: Standard parts are provided in the parts lists. Cases may be equipped with specialty parts that were incorporated into the case(s) at the time they were manufactured. It is important to have the case serial number when contacting Kysor//Warren for replacement parts.

3200 Series Glass – Measuring Glass

Information required for cases built since the beginning of 2004:

Need: Case Model and Serial Number. The model number tells us the shape of the glass and the serial number allows us to verify the type of glass that was shipped with the case (non-glare or standard).

Information required for cases built prior to the beginning of 2004:

If case labeling is intact the case model and serial number are needed.

Curve Glass Measurements

a. Height of the Curve Glass:

Hook the measuring tape on bottom edge of glass and pull tape over the top of the glass around the curve until reaching the top edge. The measurement for curved glass should be approximately 33-3/4" for our "A" glass version or 41" for our "B" glass version. If broken, measure the height of the same type of case within the same line up.

b. Width of the Curve Glass:

Non-corner case glass (top and bottom edges are of the same length): If original glass is broken, measure the length of the glass clamp to get the approximate glass width.

c. Corner Case Curve Glass (different lengths for the top or the bottom edge):

If original glass is broken, measure the glass clamp length to get the approximate glass width at the top. The bottom edge should be measured from the glass or end panel that is positioned next to the broken piece. The measuring tape should be aligned where the bottom edge of the glass would normally sit. Please also indicate if the case makes an inside corner or an outside corner in the store. This can be determined by standing at the corner of the customer's side of the case. If the corner points away from your position, it is an inside corner and if it points towards your position, it is an outside corner case.

Flat Glass Measurements

a. Height of the flat glass - Hook the measuring tape on bottom edge of glass and pull the tape the top edge. If broken measure the height of the same type of case within the same line up.

b. Width of the flat glass - Non-corner case flat glass (top and bottom edges are of the same length): If original glass is broken, measure the length of the glass clamp to get the approximate glass width.

c. Corner case flat glass (different lengths for the top or the bottom edge) - If original glass is broken, measure the length of the glass clamp to get the approximate glass width at the top. The bottom edge should be measured from the glass or end panel that is positioned next to the broken piece. The measuring tape should be aligned where the bottom edge would normally sit. Please also indicate if the case makes an inside

corner or an outside corner in the store. This can be determined by standing at the corner of the customer's side of the case. If the corner points away from your position, it is an inside corner and if it points towards your position, it is an outside corner case.

Glass type: Non-glare or standard

Non-glare coated glass will have less of a reflection than standard glass. While standing in front of the case, position yourself in a manner that would allow you to see the reflection of the overhead lights (normal un-colored overhead lighting). The reflection should have a slight reddish or purplish reflection.

Standard glass will reflect the same color as the overhead lighting.

Warranty

Parts Warranty Policy

The following procedures are in accordance with Kysor//Warren's standard one-year warranty, which covers any part to be free of defects under normal use and service for one year from the date of installation. **Not to exceed one year and thirty days from the date of original shipment from the factory.**

New Equipment Parts Shortages and Defects

Any parts shortages or damage must be reported to Kysor//Warren no more than 10 working days from the date of delivery. After this time has expired Kysor//Warren will assume the parts were lost during installation and all parts required will be charged cost plus shipping to replace.

Parts Ordering Procedure

All parts must be ordered through the Kysor//Warren parts department with the following information:

- Store Name and Number
- Location
- Case or Case Model and Serial Number
- Firm or Contractor Placing Order
- Shipping Address
- Parts Description
- Reason for Defect

If the order is for a replacement part still in warranty a Purchase Order Number will be required from the contractor placing the order. We will then issue a Return Material Authorization Tag (RMA) that will be sent to the firm or contractor who has ordered the part.

Return Authorization Procedure

Warranty parts must be returned postage prepaid to Kysor//Warren within 30 days from replacement part ship date and must be accompanied by a RMA in order to ensure the proper credit. The RMA should also be written on the outside of the box. Any parts not returned within 30 days will be invoiced to the firm or contractor who has placed the order.

IN THE CONSTANT EFFORT TO IMPROVE OUR PRODUCTS, WE RESERVE THE RIGHT TO CHANGE AT ANYTIME SPECIFICATIONS, DESIGN, OR PRICES WITHOUT INCURRING OBLIGATION.

One-Year Warranty

KYSOR//WARREN warrants to the original purchaser this new equipment and all parts thereof, to be free from defects in material and workmanship under normal use and service. If any part or parts of the equipment should prove defective during the period of one year from installation date (not to exceed one year and thirty days from the date of original shipment from the factory), KYSOR//WARREN hereby guarantees to replace or repair, without charge (F.O.B. Columbus, Georgia), such part or parts as proven defective, and which KYSOR//WARREN'S examination disclosed to its satisfaction to be thus defective, with a new or functionally operative part. The liability of KYSOR//WARREN under this warranty shall be limited to claims made by the original purchaser to KYSOR//WARREN or its local distributor within the warranty period.

THIS WARRANTY IS IN LIEU OF ALL OTHER WARRANTIES, EXPRESSED, IMPLIED OR STATUTORY, INCLUDING, BUT NOT LIMITED TO ANY WARRANTY OF MERCHANTABILITY OR FITNESS, AND ALL OTHER OBLIGATIONS OR LIABILITIES OF KYSOR//WARREN.

I. GLAZING:

Glass is not guaranteed against breakage. If this refrigerator is equipped with a glazing assembly carrying the manufacturer's brand name (Thermopane, Twindow, etc.), the manufacturer's glazing warranty in effect at the time of this shipment is extended to that assembly. It is void outside the continental United States.

II. BULBS:

Light bulbs and fluorescent lamp tubes are not covered by any warranty for length of life or for any type of breakage.

III. THIS WARRANTY SHALL NOT APPLY:

1. To the condensing case used with refrigerated equipment unless same was sold and shipped by KYSOR//WARREN.
2. When this equipment or any part thereof is damaged by fire, flood, act of God, or when the original model and serial number plate has been altered, defaced, or removed.
3. When this equipment or any part thereof is subject to accident, alteration, abuse, misuse, tampering, operation on low or improper voltages, or is put to a use other than recommended by KYSOR//WARREN.
4. When this equipment or any part thereof is damaged, or when operation is impaired, due to failure to follow installation manual (improper installation is the responsibility of the installer).
5. Outside the continental United States, Canada and Mexico.
6. To labor cost for replacement of parts, or for freight or shipping expenses.
7. To freight or shipping charges or to customs duties to any country.
8. If the Warranty holder fails to comply with all the provisions, terms and conditions of this Warranty.

Parts replaced under this Warranty are warranted only through the remainder of the original Warranty. KYSOR//WARREN may, at its option and in its discretion, elect to honor this Warranty and to disregard the original purchaser's non-compliance with any of the provisions, terms and conditions of the Warranty.

THIS WARRANTY DOES NOT COVER CONSEQUENTIAL DAMAGES.

KYSOR//WARREN shall not be liable under any circumstances for any consequential damages, including loss of profits, additional labor costs, loss of refrigerant or food products, or injury to person or property caused by defective material or parts or for any delay in the performance of this Warranty due to causes beyond its control. The foregoing shall constitute the sole and exclusive remedy of any purchase and the sole and exclusive liability of KYSOR//WARREN in connection with this product.

KYSOR//WARREN

5201 Transport Blvd

Columbus, Georgia 31907

800-866-5596

Telephone:

1-800-866-5596

Email:

solutions@kysorwarren.com

Website

<http://www.kysorwarren.com/>

Kysor//Warren, whose policy is one of continuous improvement, reserves the right to change at anytime, these specifications, designs or prices without incurring obligation.

KYSOR  **/WARREN**

