

# INSTALLATION & SERVICE INSTRUCTIONS

FOR MODEL(S)

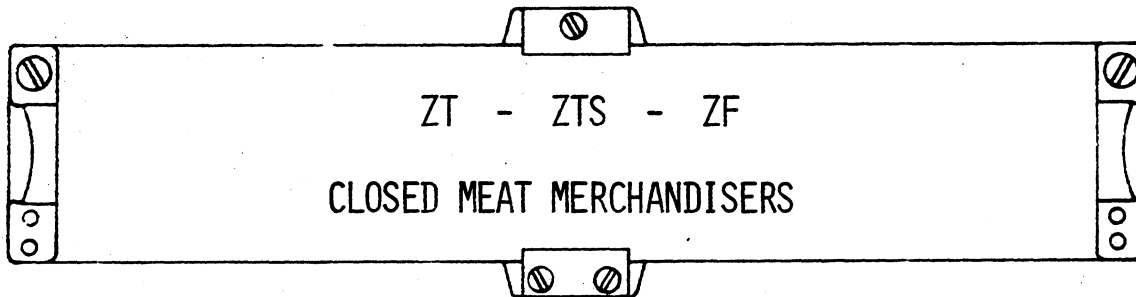

**please retain  
for future use**

**engineering dept.  
bulletin # 75-105-2**

IN THE CONSTANT EFFORT TO IMPROVE OUR PRODUCTS WE  
RESERVE THE RIGHT TO CHANGE AT ANY TIME SPECIFICATIONS  
DESIGN, OR PRICES WITHOUT INCURRING OBLIGATION

**KYSOR**

P. O. Box C  
1600 Rockdale Industrial Blvd.  
Conyers, Georgia 30207  
404 483-5600

**WARREN / SHERER**

DIVISION OF KYSOR INDUSTRIAL CORPORATION

West Industrial Road  
Marshall, Michigan 49068  
616 781-3911



### INTRODUCTION

The following instructions are provided for your information to facilitate ease and economy of installation along with longevity of product service. Please utilize this important tool to its utmost. For information not contained in this booklet please consult directly with your Warren/Sherer Engineering or Service Department.

### DESCRIPTION AND PURPOSE OF UNIT

#### Description

Utilized to display fresh meats, deli, fresh fish and poultry, the ZT series provides precise product temperature at ideal humidity all contained within a well lit product-projecting display.

These fixtures are built for continuous line-up, and are not sold as self-contained units. A continuous line-up may be made that incorporates the ZT, ZTS, and ZF cases.

<u>MODEL</u>	<u>DESCRIPTION</u>	<u>SERIAL NUMBER DESIGNATION</u>
ZT	Sculptured Profile Top Display Fresh Meat Case _____	382
ZTS	Sculptured Profile Top Display and Storage Fresh Meat Case _____	383
ZF	Sculptured Profile Fish and Poultry Case _____	384

### COMPRESSOR REQUIREMENTS

Compressor requirements are listed in the Appendix for various length lineups based on stores having a maximum of 90° ambient and 60% RH.

### MAINTENANCE

Periodically, racks and shelving should be removed and washed thoroughly using a detergent such as Tide, or preferably a bactericidal commercial cleaner. All interior surfaces should be wiped down with a solution of 1/2 cup Lysol (or equal) to one gallon of warm water. All areas should be wiped dry after cleaning. Use a glass cleaner on glass.

### INSTALLATION

#### Leveling

Your Warren Refrigerator must be perfectly level to insure proper operation of the refrigeration system and also to insure proper drainage after defrost.

Proper leveling when multiplexing can be accomplished by finding the highest point on the floor at the location of the line-up by using a level and a chalk line. Place a refrigerator at this point and use shims as needed to line the other refrigerators to this high point. Make sure shims of sufficient quality are employed to prevent settling.

### DEFROSTING

To properly maintain desired temperature in your closed case, it is necessary to use a defrost timer. The normal defrost is one time a day and usually at night. We recommend a straight time defrost for a period from 75 to 90 minutes duration. In some instances, it may become necessary to increase the defrost to two times daily. This usually occurs in very humid areas or when your refrigerator has a very heavy usage. The suction pressure during defrost should reach 42-46 psi to insure proper drainage of the condensate collected during the running cycle.

### REFRIGERANT

All compressors on Warren sculptured profile meat case use R-12 refrigerant, and the amount of charge is variable, depending on the size of the compressor and the run of tubing.

### OIL

Only pure refrigeration oil as specified by the compressor manufacturer is to be used - Viscosity 300. Each compressor is charged with oil at the factory, but, the oil level should be periodically checked according to the compressor manufacturer's recommendations.

### EXPANSION VALVE

Pressure limiting thermostatic expansion valves are used on these refrigerators. Inlet connections are 1/4 - 3/8 male SAE and outlet connections are 3/8 - 1/2 male SAE.

### LIGHTS

A row of Natural fluorescent lamps are located above the front glass to give approximately 80 foot candles of illumination in the front display area. Another row of lights are located above the rear sliding doors to give adequate lighting at the rear of the refrigerator. The rear light has a separate switch and can be turned on and off as the user deems necessary. The switch on the outside of the refrigerator controls both lights. The two receptacles are rated at 660 watts each or about 6 amperes, which is sufficient for scales, but not suitable for large motors usually found in meat departments.

### DRAINS

Warren sculptured profile meat cases are equipped with a 1" drain connection, which terminates in the toe space at both the front and the back of the refrigerator. Be sure to keep the drain cap in place. Note: Be sure that the holes through which the refrigerant tubing enters the case are properly plugged with mastic that will prevent the escape of cold air.

### MULTIPLE CASE INSTALLATION

Only one pair of ends should be ordered. See price list. Where cases join, a sealer is used to keep moisture and debris from getting into the joint. There should be two bead of this sealer used for this purpose. The sealer should be placed around the inside and outside edges of each case before they are pulled up. Cases made into a continuous line-up are held together at each joint by eight (8) 3/8" hex bolts. There are two (2) bolts in the cross member at the center of the end, two (2) bolts at the front of the case, and two (2) bolts in the back of the case. The remaining two (2) bolts are at the outside bottom of the fixture. Tighten these bolts first.

### START-UP

#### Electric

Make sure that the proper electric current is supplied. Check electric current characteristics on compressor name plate, which must correspond with available current, and should correspond with wiring diagrams and refrigerator name plate. The size of wires and all wiring devices and materials must conform to local and national codes.

### CONTROLS

Thermostats are not furnished installed as standard equipment on ZT, ZTS, or ZF fixtures. When thermostatic control is desired on a line-up of cases refrigerated by one compressor, select the case that will have the greatest fluctuation of air temperatures and use the control on it. When thermostats are ordered with the fixtures, the bulbs will be installed at the factory. Pressure controls are often used on multiple line-ups, where the compressors are not subjected to below freezing temperatures. This is left to the discretion of the installer. Recommended pressure control settings should be 28 pounds cut-in and 18 pounds cut-out for delicatessen and 27 pounds cut-in and 16 pounds cut-out for fresh meat. These settings will not maintain a defrosting cycle.

### DEHYDRATION OF REFRIGERATION SYSTEM

#### PLEASE READ CAREFULLY BEFORE PLACING SYSTEM INTO OPERATION

1. After laying refrigerant lines, they should be blown out before making final connection at fixture or condensing unit. Use either carbon dioxide or dry nitrogen to prevent any foreign matter being left in the lines. Keep pressure below 250 pounds.
2. To prevent scaling due to brazing, dry nitrogen should be allowed to flow through lines while brazing operations are taking place.
3. After installation is complete and checked for leaks, pump a deep vacuum using a vacuum pump. DO NOT USE THE CONDENSING UNIT FOR THIS PURPOSE!!!
4. Break vacuum on system by releasing refrigerant through a dehydrator until pressure gauge reads above zero pounds. Repeat steps three and four.
5. A dehydrator should be used in the charging line when adding refrigerant.
6. A dehydrator of sufficient capacity must be installed in the liquid line before placing system into operation.

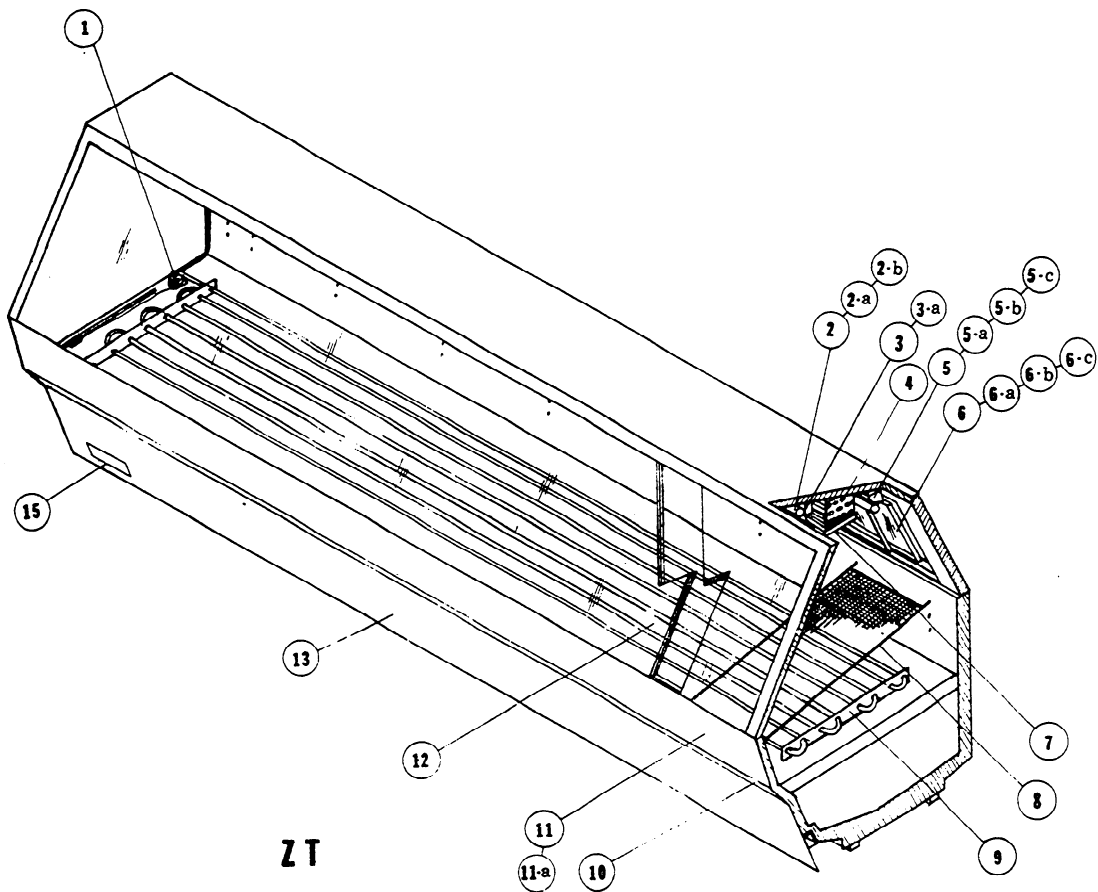
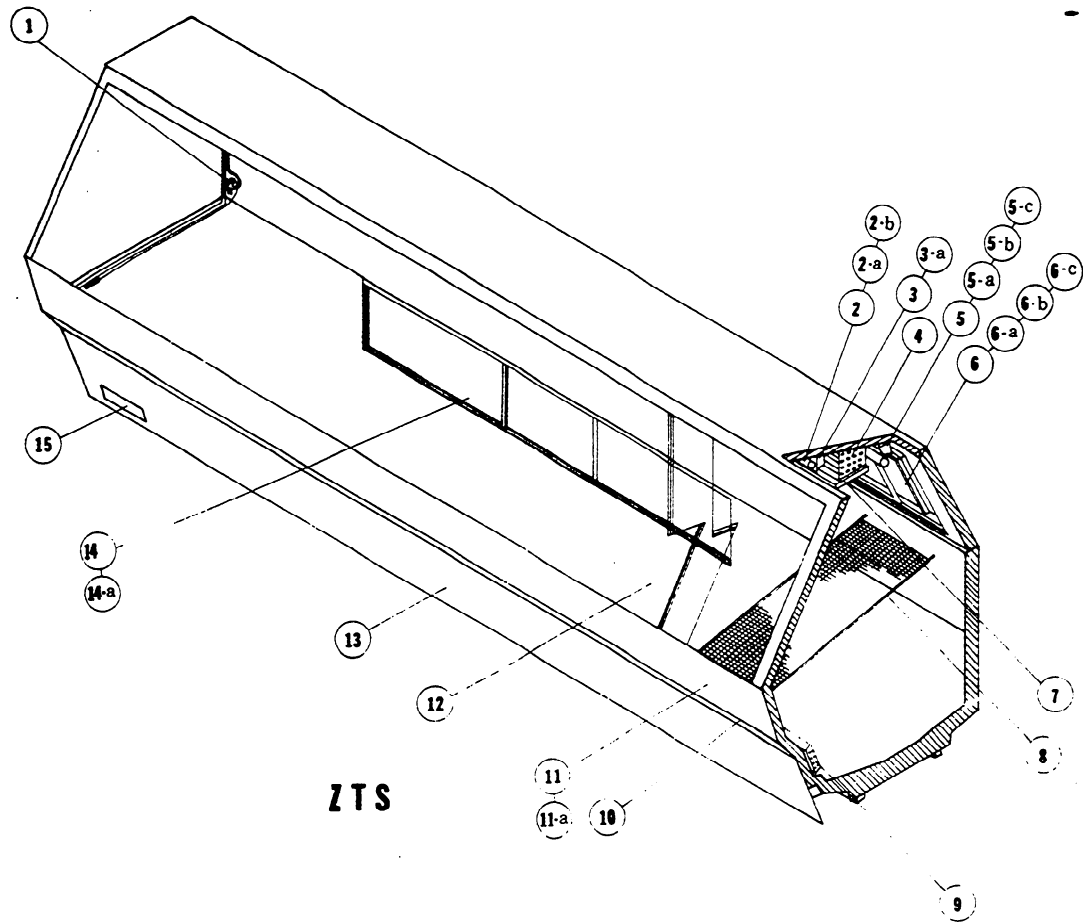

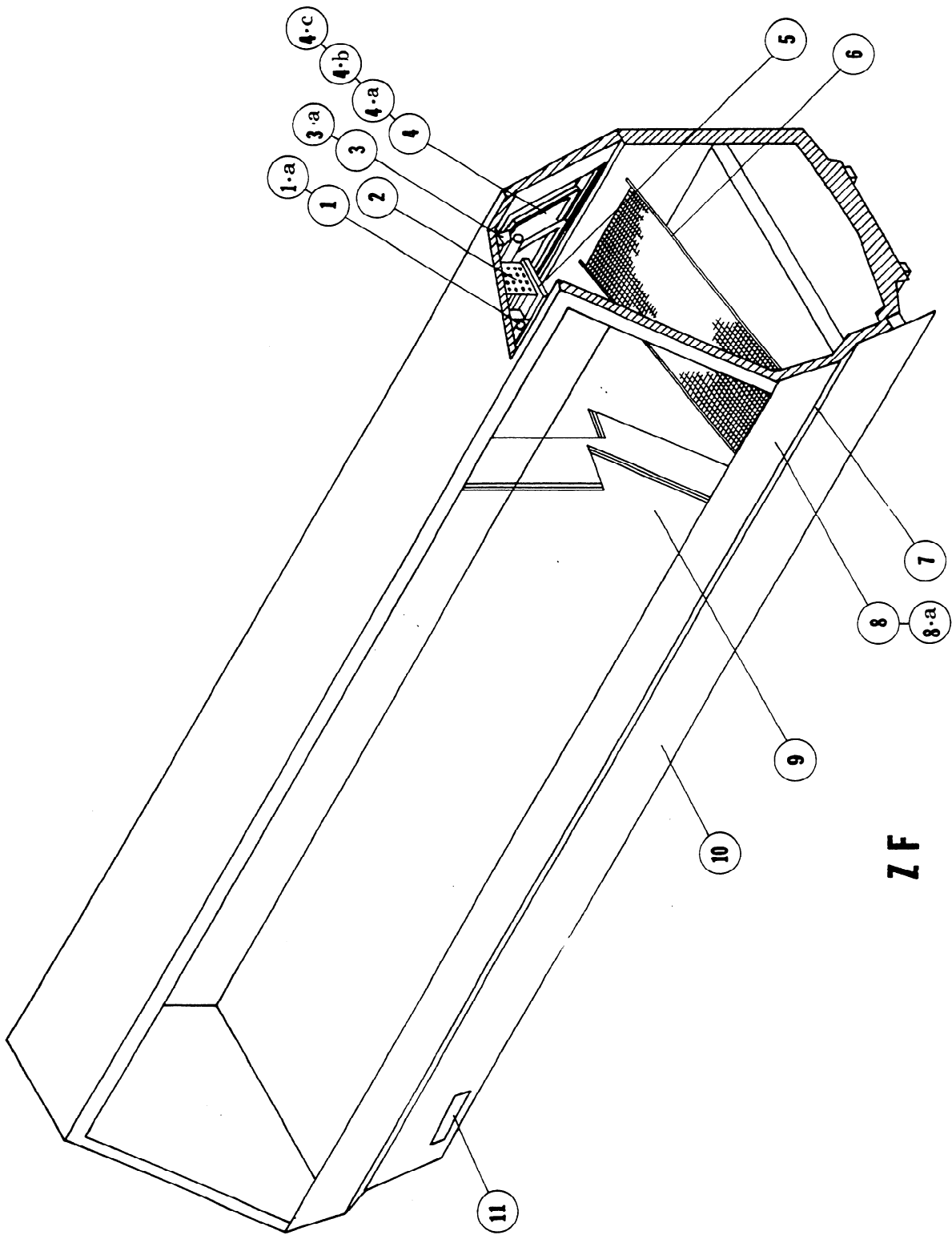

Z F

	REF. NO.	ZF	
		8'	12'
FLUORESCENT BULB	1	10A10-22	10A10-22
STARTERS	1A	10J12-11	10J12-11
*12-TUBE COIL ASSEMBLY	2		
LIGHT RAIL COVER ASSEMBLY	3	80B14-10	80B18-10
LIGHT RAIL ASSEMBLY	3A	80B17-10	80B19-11
LEFT-HAND INSIDE DOOR ASSEMBLY	4	90E11-22	90E12-14
RIGHT-HAND INSIDE DOOR ASSEMBLY	4A	90E11-23	90E12-17
LEFT-HAND OUTSIDE DOOR ASSEMBLY	4B	90E11-24	90E12-16
RIGHT-HAND OUTSIDE DOOR ASSEMBLY	4C	90E11-25	90E12-15
*TOP COIL DRIP PAN ASSEMBLY	5	89D11-17	89D13-12
TYPICAL WIRE RACK - FLAT***	6	28G19-85	28G19-85
COLOR BAND BUMPER	7	15J11-16	15J11-18
COLOR BAND PORCELAIN	8	51A17-33	51A19-33
COLOR BAND	8A	15J10-16	15J10-15
**MULTI-PANE 2-PANE ASSEMBLY	9	14D10-60	14D10-61
KICKPLATE	10	56E10-40	56E10-39
RACEWAY HANDY BOX COVER	11	51W25-87	51W25-87
*12-TUBE COIL ASSEMBLY IS AN ACCESSORY INCLUDING EXPANSION VALVE		3A10-17	3A10-17
**A MULTI-PANE 3-PANE ASSEMBLY CAN BE ORDERED AS AN ACCESSORY		14D11-32	14D11-33
*** ACCESSORY - 2-STEP WIRE RACK		28G19-86	28G19-86
3-STEP WIRE RACK		28G19-87	28G19-87



	REF. NO.	ZT		ZTS	
		8'	12'	8'	12'
EXPANSION VALVE	1	3A10-17	3A10-17	3A10-17	3A10-17
FLUORESCENT BULB F30T-8N	2	10A10-17	10A10-17	10A10-17	10A10-17
FLUORESCENT BULB F15T-8N	2A	10A10-18	10A10-18	10A10-18	10A10-18
FLUORESCENT BULB F40T-12N	2B	10A10-22	10A10-22	10A10-22	10A10-22
STARTERS FS-2	3	10J12-10	10J12-10	10J12-10	10J12-10
STARTERS FS-4	3A	10J12-11	10J12-11	10J12-11	10J12-11
12-TUBE COIL ASSEMBLY	4	86C10-28	86E10-17	86C10-28	86E10-17
LIGHT RAIL ASSEMBLY	5	80B17-10	80B19-11	80B17-10	80B19-11
LIGHT RAIL COVER ASSEMBLY	5A	80B14-10	80B18-10	80B14-10	80B18-10
REAR LIGHT RAIL ASSEMBLY	5B	80B18-11	80B20-11	80B18-11	80B20-11
REAR LIGHT REFLECTOR	5C	54T14-18	54T14-19	54T14-18	54T14-19
LEFT-HAND INSIDE DOOR ASSEMBLY	6	90E11-22	90E12-14	90E11-22	90E12-14
LEFT-HAND OUTSIDE DOOR ASSEMBLY	6A	90E11-24	90E12-16	90E11-24	90E12-16
RIGHT-HAND INSIDE DOOR ASSEMBLY	6B	90E11-23	90E12-17	90E11-23	90E12-17
RIGHT-HAND OUTSIDE DOOR ASSEMBLY	6C	90E11-25	90E12-15	90E11-25	90E12-15
TOP COIL DRIP PAN ASSEMBLY	7	89D11-17	89D13-12	89D11-17	89D13-12
TYPICAL WIRE RACK - FLAT**	8	28G19-85	28G19-85	28G19-85	28G19-85
8-TUBE COIL ASSEMBLY	9	86K12-15	86K12-16	86C10-29	86D10-16
COLOR BAND BUMPER	10	15J11-16	15J11-18	15J11-16	15J11 8
COLOR BAND PORCELAIN	11	51A17-33	51A19-33	51A17-33	51A19-33
COLOR BAND	11A	15J10-16	15J10-15	15J10-16	15J10-15
*MULTI-PANE 2-PANE ASSEMBLY	12	14D10-60	14D10-61	14D10-60	14D10-61
KICKPLATE	13	56E10-40	56E10-39	56E10-40	56E10-39
OUTER DOOR ASSEMBLY - STORAGE	14			90A16-19	90A16-29
<del>INNER</del> DOOR ASSEMBLY - STORAGE	14A			90A16-20	90A16-22
RACEWAY HANDY BOX COVER	15	51W25-87	51W25-87	51W25-87	51W25-87
*A MULTI-PANE 3-PANE ASSEMBLY		14D11-32	14D11-33	14D11-32	14D11-33
CAN BE ORDERED AS AN ACCESSORY					
**ACCESSORY - 2-STEP WIRE RACK		28G19-86	28G19-86	28G19-86	28G19-86
3-STEP WIRE RACK		28G19-87	28G19-87	28G19-87	28G19-87

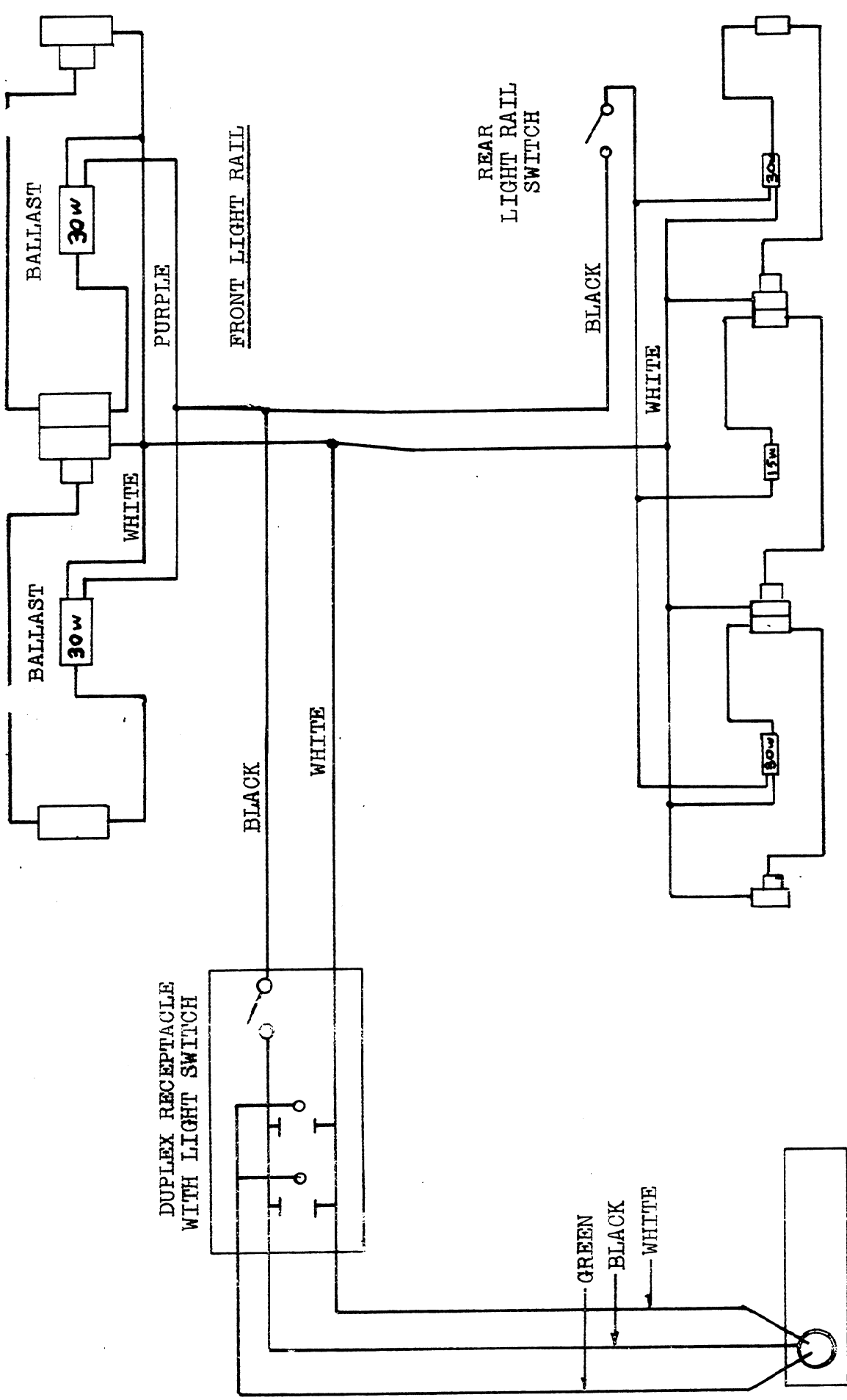

DUPLEX RECEPTACLE WITH LIGHT SWITCH

BLACK

WHITE

BALLAST

30W

WHITE

PURPLE

FRONT LIGHT RAIL

REAR LIGHT RAIL SWITCH

BLACK

WHITE

30W

15W

30W

RACEWAY HANDY BOX  
120V-60 CYCLE

REAR LIGHT RAIL  
(ACCESSORY ON ZF)

TITLE ZT, ZTS, ZF-8' CASE  
WIRING DIAGRAM

DRAWN P.C.L.

APPROVED

SCALE

DATE 2-8-67

THE WARREN COMPANY  
INCORPORATED  
ATLANTA 1, GEORGIA

DRAWING NUMBER  
PAW-10647

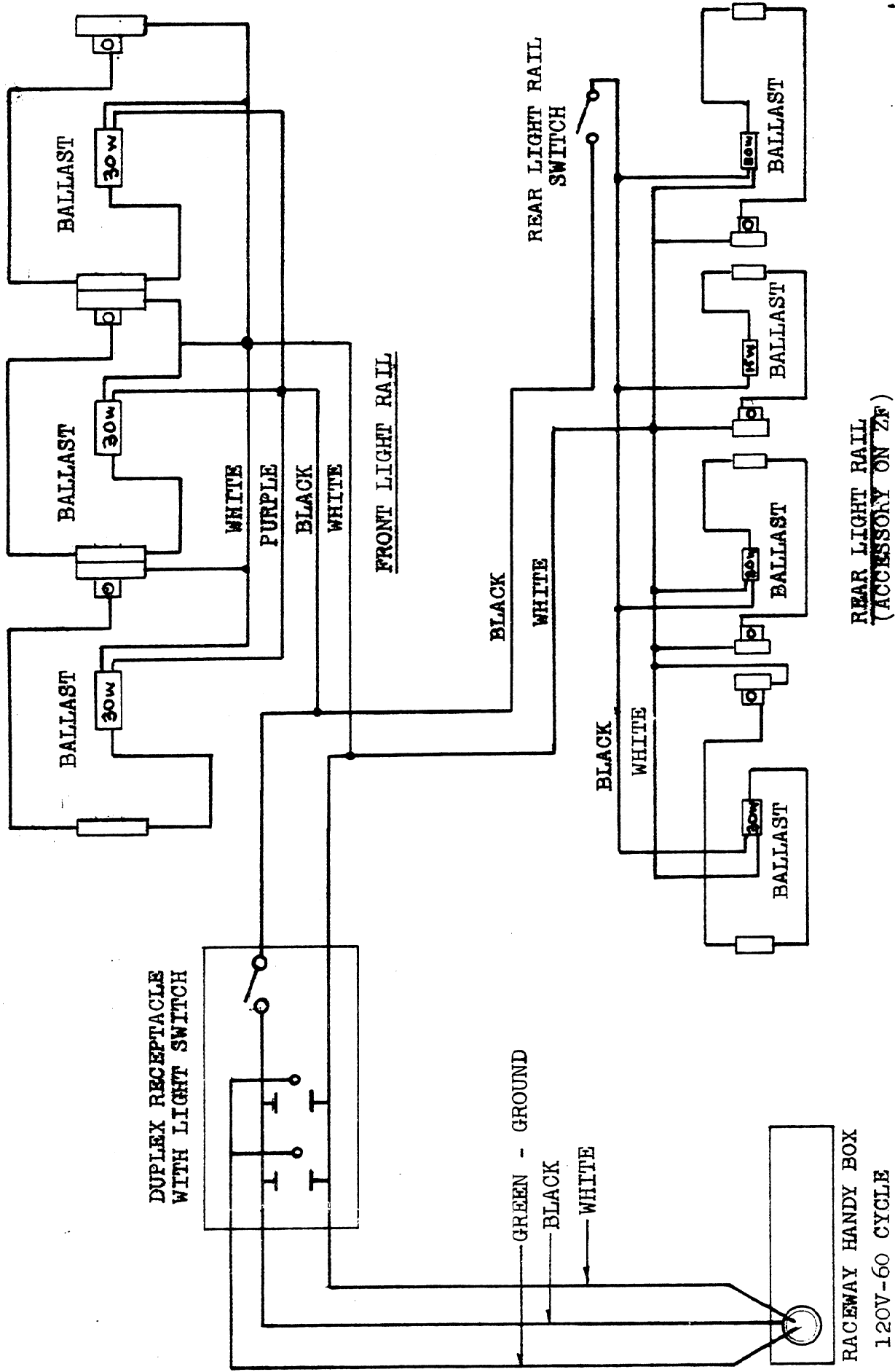

TITLE ZT, ZTS, ZF-12' CASE WIRING DIAGRAM	DRAWN P. C. L.	SCALE	DRAWING NUMBER
	APPROVED <i>[Signature]</i>	D/ 2/8/67	PAW-10648
		THE WARREN COMPANY INCORPORATED ATLANTA 1, GEORGIA	

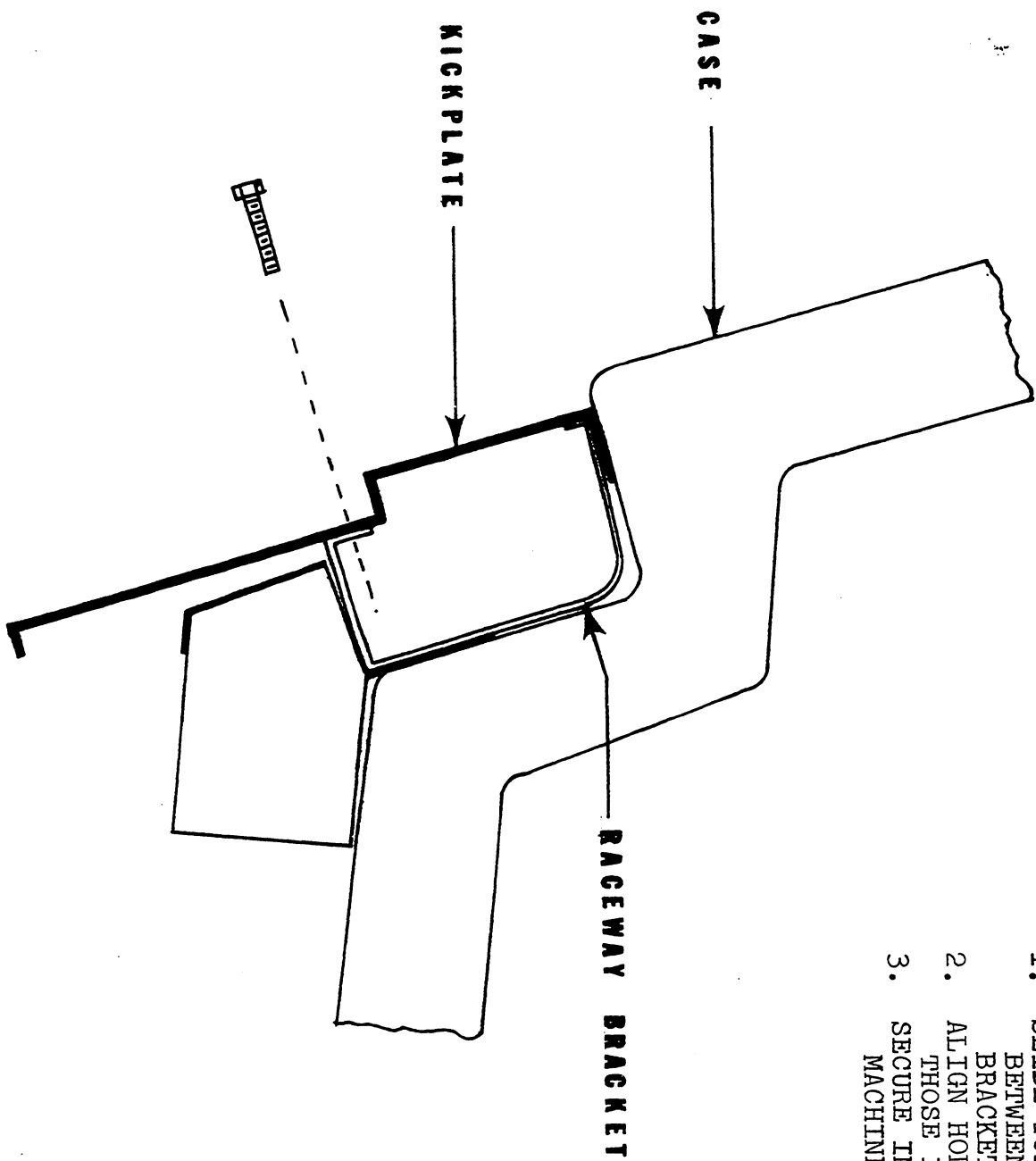

1. SLIDE TOP FLANGE OF KICKPLATE BETWEEN CASE AND RACEWAY BRACKET.
2. ALIGN HOLES IN KICKPLATE WITH THOSE IN RACEWAY BRACKET.
3. SECURE IN PLACE WITH #10-24 x 1/2" MACHINE SCREWS.



SEES	LINEAR FEET	R-12		R-502		ELECTRICAL DATA	
		COMPRESSION SIZE		SIZES		115V AMPS	
		FC	RC	0-75'	75-150'	DEFROST AMPS	115V AMPS
1	8	1/2 HF	RC	3/8	3/8	208V 1PH	3.1
1	12	70				230V 1PH	4.5
2	16	100				208V 1PH	6.2
1	20	150				230V 1PH	7.6
2	24	150				208V 1PH	9.1
2	28	150		1/2	1/2	230V 1PH	10.7
1	32	200	210	1/2	1/2	208V 1PH	12.1
3	36	200	210			230V 1PH	13.5
2	40	200	210	1/8	1/8	208V 1PH	15.2
1	44	300	210			230V 1PH	16.6
4	48	300	310			208V 1PH	18.0
2	52	300	310	1/8	1/8	230V 1PH	19.7
1	56	300	310			208V 1PH	21.1
5	60	300	310	5/8	5/8	230V 1PH	22.5
2	64	500	310			208V 1PH	24.2
1	68	500	410	1/8	1/8	230V 1PH	25.6
6	72	500	410			208V 1PH	27.0
2	76	500	410			230V 1PH	28.7
1	80	500	410	5/8	5/8	208V 1PH	30.1
7	84	500	410			230V 1PH	31.5
2	88	500	510			208V 1PH	32.2
3	92	550	510	1/8	1/8	230V 1PH	34.6
8	96	550	510			208V 1PH	36.0

-13-

NOTES:

1. COMPRESSOR RECOMMENDATIONS ARE BASED ON STATES HAVING A HAILFALL OF 50" AMBIENT AND 65° F. H.
2. SAE (SAE-CR-100) UNITS ARE BASED ON 90° AIR OUTSIDE COMPRESSOR. SWM (WATER-ENTERING COMPRESSOR) WITH USING REAR COMPRESSOR COMPONENTS UNITS "WATER" USE 90° RECOMMENDATIONS OF "WATER".
3. SUFFICIENT UNITS ARE AS FOLLOWS: LOW-TEMPERATURE--1/2" (1/2" REFRIGERANT); 1/4" (1/4" REFRIGERANT); 1/8" (1/8" REFRIGERANT); 1/16" (1/16" REFRIGERANT); 1/32" (1/32" REFRIGERANT); 1/64" (1/64" REFRIGERANT).

4. CAUTION: THESE RECOMMENDATIONS ARE BASED ON THE UNIT AS SHOWN IN THE ABOVE. SINCE CONDITIONS MAY VARY FROM THESE RECOMMENDATIONS THAT PROTECT USING THESE RECOMMENDATIONS DO SO AT THEIR OWN DISCRETION AND RISK. WE CAN ASSUME NO LIABILITY FOR RESULTS OBTAINED AS A CONSEQUENCE OF APPLICATIONS OUTSIDE OF WAREHSE'S CONTROL.
5. RISERS--IN THE SUCTION LINE ANY ELEVATION AS MUCH AS SIX FEET OR MORE MUST BE SHOWN. SUCTION LINE RISERS TO THE MET SHALL BE INSTALLED AT THE BOTTOM.
6. EQUIVALENT LENGTH IS LENGTH FROM COMPRESSOR TO REFRIGERATOR FURTHER FROM COMPRESSOR PLUS 4' FOR EACH FITTING IN MAIN TRUNK LINE. USING THIS EQUIVALENT LENGTH.

7. EXPOSED SUCTION LINES SHOULD BE INSULATED TO PREVENT CONDENSATE DRIP.
8. ELECTRICAL WIRE SIZES ARE BASED ON AMERICAN WIRE GAUGE FOR 100 FEET OF THERMOPLASTIC TYPE T & TV.

9. LIGHTS--AMPERAGE LISTED IS FOR STANDARD LIGHTING, MOORE EXTRA LIGHTS ARE USED CHECK WIREPLATE DATA.
10. DEFROST VOLTS: FOR 208V/1-PHASE, MULTIPLY 230V AMPS BY 0.9. FOR 230V/1-PHASE, MULTIPLY 230V AMPS BY 0.95. FOR 208V/1-PHASE, MULTIPLY 208V AMPS BY 1.04. THREE PHASE APPROPRIATE (A/L/C) IS THE MAXIMUM PER LEG.

WAREHSE REFRIGERANT LINES  
 & ELECTRICAL DATA  
**UP TO 90° STORE**  
 BTU DATA BASED ON +7.5° SUCTION  
 CALCULATE TOTAL LENGTH OF  
 LINES AND THEN ADD 4' FOR  
 EACH FITTING.  
 COMPRESSOR SIZE CHART