

# DX4LN - STRATUS

## MULTI-DECK SPECIFICATION SHEET



General Case Data	Case Length (ft)			
	4'	6'	8'	12'
Total Display Area (ft <sup>2</sup> )	13.57	20.32	27.10	40.64
Cubic Capacity (ft <sup>3</sup> )	32.94	49.33	65.81	98.67
Max Shelf Depth (in) [Top/Bottom]	22/24	22/24	22/24	22/24
Weight (lb)	-	-	-	-
<b>Refrigeration Data (General)</b>				
Discharge Air Velocity (fpm)	200-300	200-300	200-300	200-300
Fan Speed (rpm)	2200	2200	2200	2200
Discharge Air Temp (°F)	35	35	35	35
Conventional Thermal Load, Single (Btuh) one row of canopy LED	4856	7284	9712	14568
Parallel Thermal Load, Single (Btuh) one row of canopy LED	4356	6533	8711	13067
Additional Btuh per ft LED - Canopy / Shelf & Nose	13 / 11	13 / 11	13 / 11	13 / 11
<b>Refrigeration Data (HFC)</b>				
Evaporator Temperature (°F)	24	24	24	24
Superheat Setpoint (°F)	6 - 8	6 - 8	6 - 8	6 - 8
Estimated Refrigerant Charge (lbs)	0.982	1.469	2.1	3.143
<b>Refrigeration Data (Glycol)</b>				
Supply Temperature (°F)	20	20	20	20
Flow (GPM)	QTE	QTE	QTE	QTE
Fluid %	35	35	35	35
Pressure Drop (PSID)	QTE	QTE	QTE	QTE
<b>Electrical Data (Amps/Watts)</b>				
115V/60Hz, 1 Phase				
Fans	0.30	0.60	0.60	0.90
Canopy Lights (Per row)				
GE LED	0.19	0.28	0.37	0.56
Shelf Lights (Per row)				
GE LED	0.06	0.09	0.12	0.19

Defrost Data (off Cycle)			
Defrosts per Day	Failsafe Duration (min) <sup>1</sup>	Termination Temp (°F)	Drip Time (min)
6	25	47	0

<sup>1</sup> At ASHRAE conditions. For conditions above 75°F, 55% RH, increase defrost time by 15 min. Type I refrigerator, intended for use in an area where the environmental conditions are controlled and maintained that conditions do not exceed 75°F and 55% relative humidity. Heatcraft Worldwide Refrigeration, whose policy is one of continuous improvement, reserves the right to change at any time specifications, designs, or prices without incurring obligation. DOE 2017 Compliant

### APPLICATIONS



The above case model has case lengths that are UL and NSF approved.

# DX4LN - STRATUS

## MULTI-DECK SPECIFICATION SHEET

### DX4LN CROSS VIEW

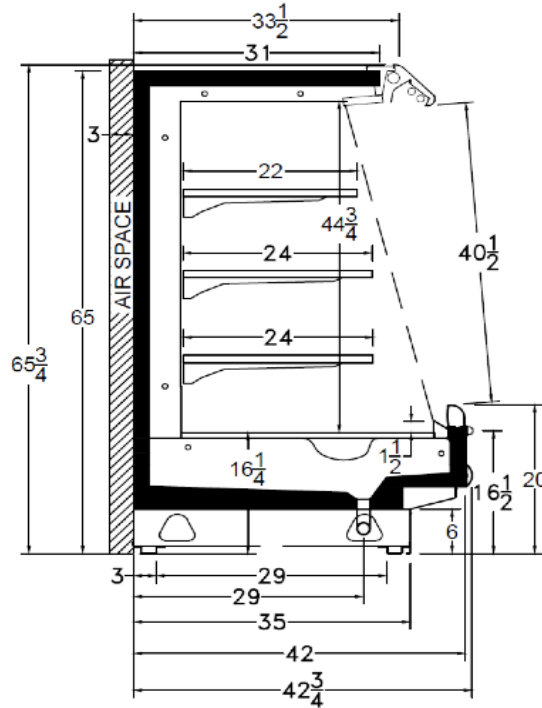

Add 3" thickness for a pair of ends.

### DX4LN PLAN VIEW (SINGLE COIL (SINGLE COIL))

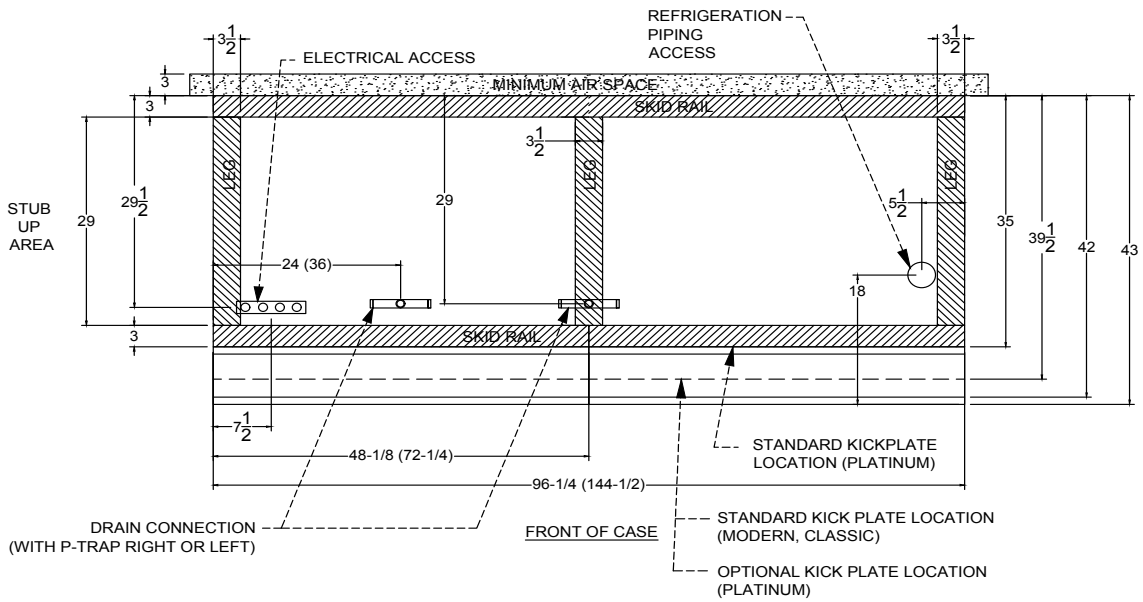

5201 Transport Blvd  
Columbus, GA 31907  
P: 800.866.5596 • F: 706.568.8990



[www.kysorwarren.com](http://www.kysorwarren.com)

