

ISSUE DATE: SEPTEMBER 2018

NS39S1- LEGACY

SERVICE SPECIFICATION SHEET



General Case Data	Case Length (ft)			
	4'	6'	8'	12'
Total Display Area (ft ²)	13.41	20.54	26.82	40.21
Cubic Capacity (ft ³)	15.87	23.77	31.71	47.54
Max Shelf Depth (in) [Top/Bottom]	8" / 12"	8" / 12"	8" / 12"	8" / 12"
Weight (lb)	650	950	1150	1400
Refrigeration Data (General)				
Discharge Air Velocity (fpm)	Gravity	Gravity	Gravity	Gravity
Fan Speed (rpm)	NA	NA	NA	NA
Discharge Air Temp (°F)	NA	NA	NA	NA
Evaporator Temperature (°F)	20	20	20	20
Conventional Thermal Load, Single (Btuh) one row of canopy LED	1172	1758	2344	3516
Conventional Thermal Load, Single (Btuh) one row of canopy T8	1204	1806	2408	3612
Parallel Thermal Load, Single (Btuh) one row of canopy LED	1109	1664	2219	3328
Parallel Thermal Load, Single (Btuh) one row of canopy T8	1141	1806	2283	3424
Additional Btuh per ft LED - Canopy / Shelf & Nose	13 / 11	13 / 11	13 / 11	13 / 11
Additional Btuh per ft T8	19	19	19	19
Superheat Setpoint (°F)	6-8	6-8	6-8	6-8
Estimated Refrigerant Charge (lbs)E	2.278	3.689	5.150	8.029
Electrical Data (Amps/Watts)				
Lighting, one row canopy LED	0.22	0.33	0.44	0.67
Lighting, one row canopy T8	0.24	0.43	0.47	0.71

Defrost Data (off Cycle)			
Defrosts Data	Per Day	Fail Safe	Termination
Off Cycle	1	80	TIME

1 At ASHRAE conditions. For conditions above 75°F, 55% RH, increase defrost time by 15 min.
 Type I refrigerator, intended for use in an area where the environmental conditions are controlled and maintained that conditions do not exceed 75°F and 55% relative humidity. Heatcraft Worldwide Refrigeration, whose policy is one of continuous improvement, reserves the right to change at any time specifications, designs, or prices without incurring obligation. DOE 2017 Compliant

APPLICATIONS



The above case model has case lengths that are UL and NSF approved.

NS39S1- LEGACY

SERVICE SPECIFICATION SHEET

NS39S1 CROSS VIEW

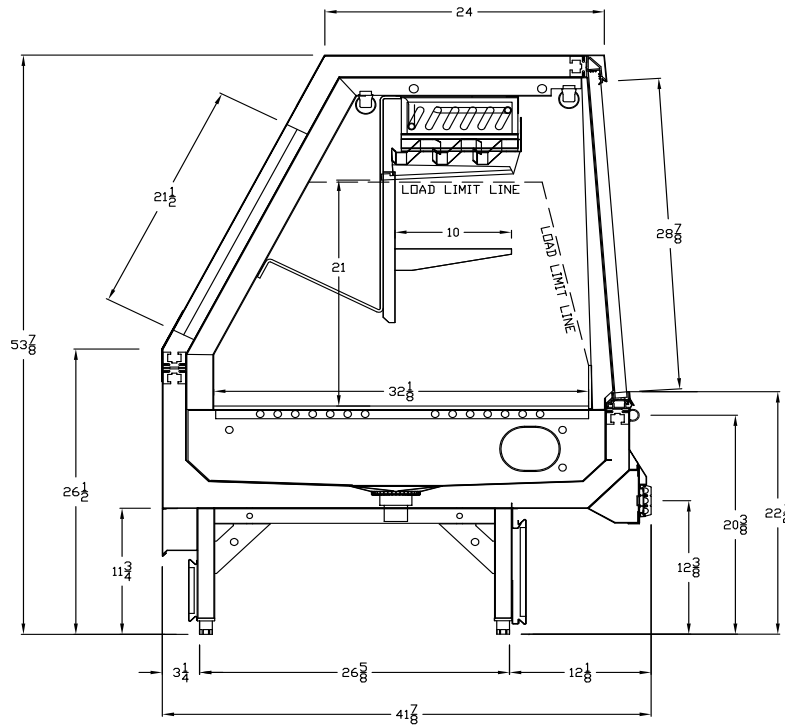

Add 3" thickness for a pair of ends.

NS39S1 PLAN VIEW

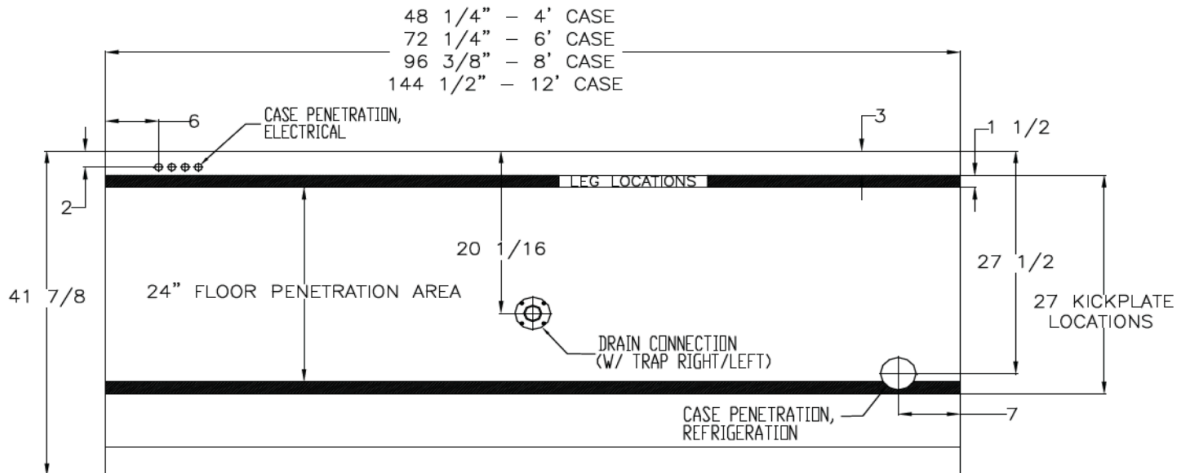

5201 Transport Blvd
Columbus, GA 31907
P: 800.866.5596 • F: 706.568.8990



www.kysorwarren.com

