

ISSUE DATE: SEPTEMBER 2018

QWST - Legacy Island

ISLAND SPECIFICATION SHEET



KYSOR WARREN
eptarefrigeration

General Case Data	Case Length (ft)		
	6'	8'	12'
Total Display Area (ft ²)	14.26	19.02	28.52
Cubic Capacity (ft ³)	19.36	25.82	38.72
Max Shelf Depth (in) [Top/Bottom]	NA	NA	NA
Weight (lb)	-	1500	1850
Refrigeration Data (All data is per side)			
Evaporator Temperature (°F)			
Frozen Food	-15	-15	-15
Ice Cream	-20	-20	-20
Dairy	24	24	24
Discharge Air Temperature (°F)			
Frozen Food	-11	-11	-11
Ice Cream	-16	-16	-16
Dairy	30	30	30
Discharge Air Velocity (fpm)			
Fan Speed (rpm)	175	175	175
Parallel Thermal Load (Btuh unlighted)			
Frozen Food	1714	2285	3427
Ice Cream	1926	2568	3853
Dairy	1155	1540	2310
Conventional Thermal Load (Btuh unlighted)			
Frozen Food	1788	2384	3576
Ice Cream	2010	2680	4020
Dairy	1260	1680	2520
Superheat Setpoint (°F)			
Estimated Refrigerant Charge (lbs)	7.504	10.324	16.035
Electrical Data (Amps/Watts)			
ECM Fan Data (Amps/Qty)			
Anti-Sweat Heater Amps (I.C./F.F./Med. Temp)	0.42 / 2	0.42 / 2	0.63 / 3
Drain Heater Amps			
Electric	0.65	0.65	0.65
Hot Gas	0.39	0.65	1.09
Defrost Heater Amps (Low/Dual Temp)			
	5.90	8.48	12.72

Defrost Data				
	Per Day	Fail Safe (min) ¹	Termination (°F)	Drip Time (min)
Electric	1	60	47	0
Hot Gas	1	25	47	0
Off Cycle	3	40	47	0

¹ At ASHRAE conditions. For conditions above 75°F, 55% RH, increase defrost time by 15 min. Type I refrigerator, intended for use in an area where the environmental conditions are controlled and maintained that conditions do not exceed 75°F and 55% relative humidity. Kysor Warren, whose policy is one of continuous improvement, reserves the right to change at any time specifications, designs, or prices without incurring obligation. DOE 2017 Compliant

APPLICATIONS



The above case model has case lengths that are UL and NSF approved.

QWST - Legacy Island

ISLAND SPECIFICATION SHEET

QWST CROSS VIEW

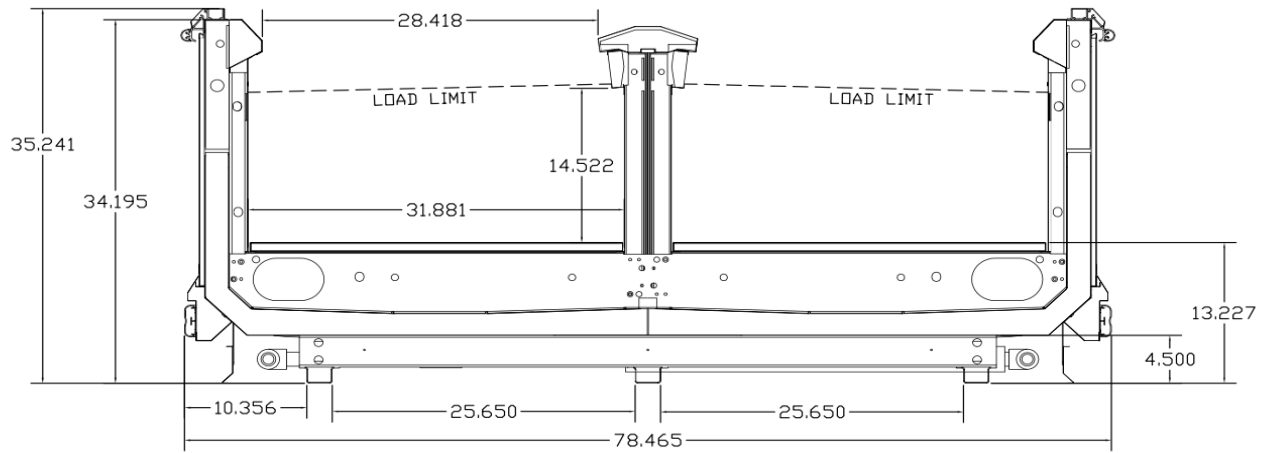

Add 3" thickness for a pair of flat ends.

QWST PLAN VIEW

