

ISSUE DATE: MAY 2019

# QWSTE- Legacy

## ISLAND SPECIFICATION SHEET



General Case Data	Case Length (ft)			
	3.5' End	4' End	4' Side	8' Side
Total Display Area (ft <sup>2</sup> )	15.87	16.09	9.51	19.02
Cubic Capacity (ft <sup>3</sup> )	19.54	19.28	12.91	25.82
Max Shelf Depth (in) [Top/Bottom]	NA	NA	NA	NA
Weight (lb)	800	800	-	-
Refrigeration Data (All data is per side)				
Evaporator Temperature (°F)				
Frozen Food	-15	-15	-15	-15
Ice Cream	-20	-20	-20	-20
Dairy	24	24	24	24
Discharge Air Temperature (°F)				
Frozen Food	-11	-11	-11	-11
Ice Cream	-16	-16	-16	-16
Dairy	30	30	30	30
Discharge Air Velocity (fpm)				
Fan Speed (rpm)	1800	1800	1800	1800
Parallel Thermal Load (Btuh unlighted)				
Frozen Food	3002	3002	1142	2285
Ice Cream	3335	3335	1284	2568
Dairy	1722	1722	770	1540
Conventional Thermal Load (Btuh unlighted)				
Frozen Food	3132	3132	1192	2384
Ice Cream	3480	3480	1340	2680
Dairy	1878	1878	840	1680
Superheat Setpoint (°F)				
Estimated Refrigerant Charge (lbs)	3.752	3.752	14.076	24.400
Electrical Data (Amps/Watts)				
ECM Fan Data (Amps/Qty)	0.42 / 2	0.42 / 2	0.21 / 1	0.42 / 2
Anti-Sweat Heater Amps (I.C./F.F./Med. Temp)	0.90	0.90	0.45	0.97
Drain Heater Amps				
Electric	0.52	0.52	0.52	0.65
Hot Gas	0.39	0.39	0.39	0.65
Defrost Heater Amps (Low/Dual Temp)				
	5.90	5.90	5.90	8.48

### APPLICATIONS



Defrost Data				
	Per Day	Fail Safe (min) <sup>1</sup>	Termination (°F)	Drip Time (min)
Electric	1	60	47	0
Hot Gas	1	25	47	0
Off Cycle	3	40	47	0

<sup>1</sup> At ASHRAE conditions. For conditions above 75°F, 55% RH, increase defrost time by 15 min. Type I refrigerator, intended for use in an area where the environmental conditions are controlled and maintained that conditions do not exceed 75°F and 55% relative humidity. Kysor Warren, whose policy is one of continuous improvement, reserves the right to change at any time specifications, designs, or prices without incurring obligation. DOE 2017 Compliant



The above case model has case lengths that are UL and NSF approved.

# QWSTE- LEGACY

## ISLAND SPECIFICATION SHEET

### QWSTE CROSS VIEW

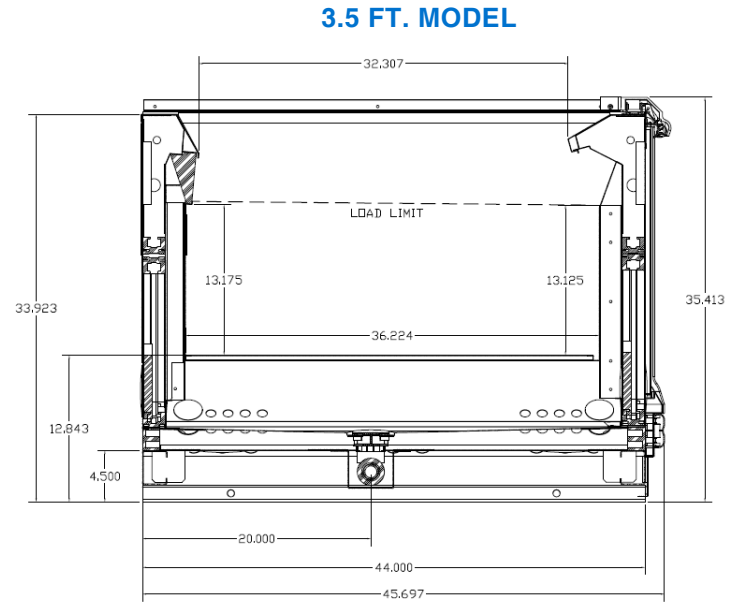
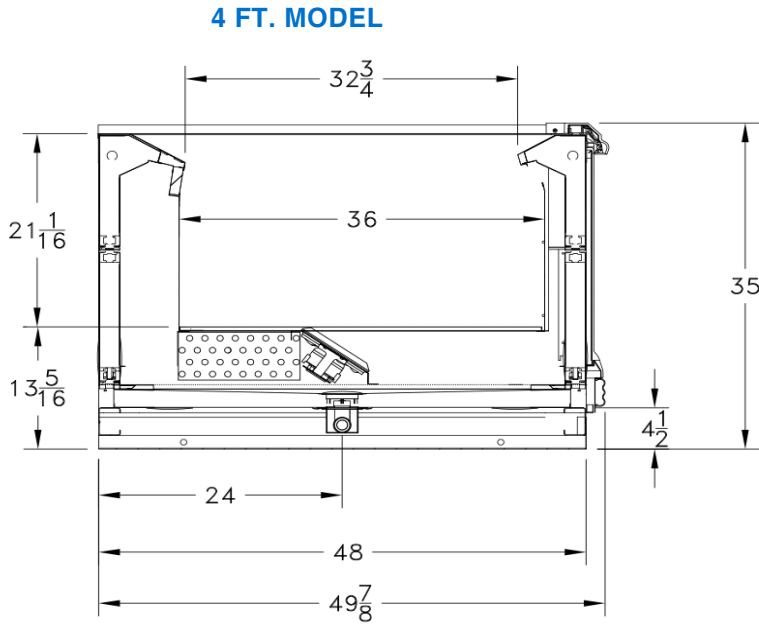

Add 3" thickness for a pair of ends.

### QWSTE PLAN VIEW

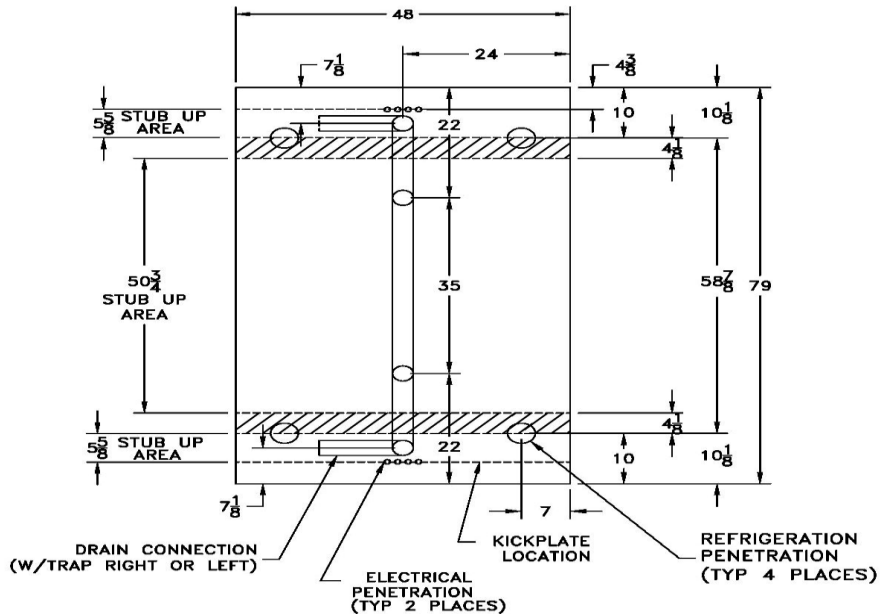

5201 Transport Blvd  
Columbus, GA 31907  
P: 800.866.5596 • F: 706.568.8990



[www.kysorwarren.com](http://www.kysorwarren.com)

