

QWSTG - Legacy Island

ISLAND SPECIFICATION SHEET



General Case Data	Case Length (ft)		
	6'	8'	12'
Total Display Area (ft ²)	17.40	23.22	34.81
Cubic Capacity (ft ³)	19.78	26.38	39.56
Max Shelf Depth (in) [Top/Bottom]	NA	NA	NA
Weight (lb)	-	-	-
Refrigeration Data (All data is per side)			
Evaporator Temperature (°F)			
Frozen Food	-15	-15	-15
Ice Cream	-20	-20	-20
Dairy	24	24	24
Discharge Air Temperature (°F)			
Frozen Food	-11	-11	-11
Ice Cream	-16	-16	-16
Dairy	30	30	30
Discharge Air Velocity (fpm)			
	175	175	175
Parallel Thermal Load (Btuh per side)			
Frozen Food	1783	2377	3565
Ice Cream	2001	2668	4002
Dairy	1208	1611	2416
Conventional Thermal Load (Btuh per side)			
Frozen Food	1860	2480	3720
Ice Cream	2088	2784	4176
Dairy	1338	1784	2676
Superheat Setpoint (°F)			
	6-8	6-8	6-8
Estimated Refrigerant Charge (lbs)			
	7.504	10.324	16.035
Electrical Data (Amps/Watts)			
ECM Fan Data (Amps/Qty)			
	0.42 / 2	0.42 / 2	0.63 / 3
Anti-Sweat Heater Amps (I.C./F.F./Med. Temp)			
	1.73	2.17	3.27
Drain Heater Amps			
Electric	0.65	0.65	0.65
Hot Gas	0.39	0.65	1.09
Defrost Heater Amps (Low/Dual Temp)			
	5.90	8.48	12.72

Defrost Data				
	Per Day	Fail Safe (min) ¹	Termination (°F)	Drip Time (min)
Electric	1	60	47	0
Hot Gas	1	20	47	0
Off Cycle	4	35	47	0

¹ At ASHRAE conditions. For conditions above 75°F, 55% RH, increase defrost time by 15 min. Type I refrigerator, intended for use in an area where the environmental conditions are controlled and maintained that conditions do not exceed 75°F and 55% relative humidity. Heatcraft Worldwide Refrigeration, whose policy is one of continuous improvement, reserves the right to change at any time specifications, designs, or prices without incurring obligation. DOE 2017 Compliant

APPLICATIONS



The above case model has case lengths that are UL and NSF approved.

QWSTG - Legacy Island

ISLAND SPECIFICATION SHEET

QWSTG CROSS VIEW

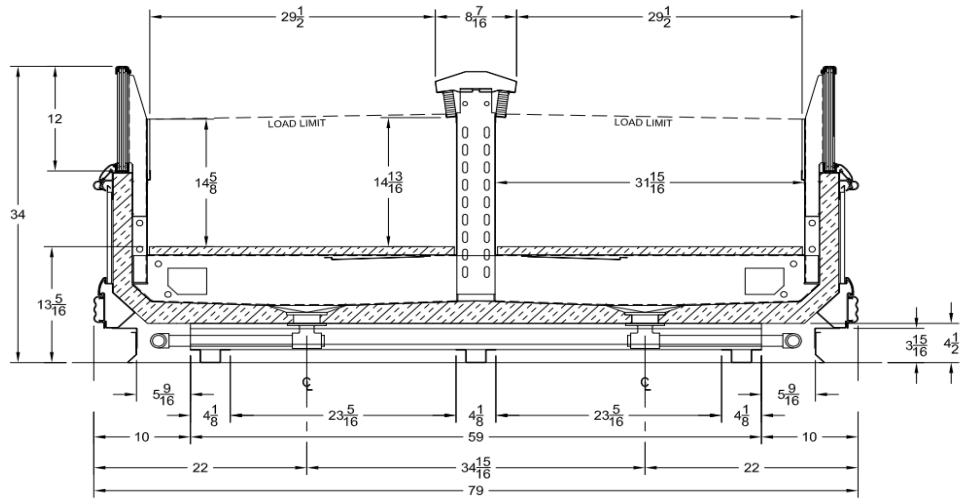

Add 3" thickness for a pair of ends.

QWSTG PLAN VIEW

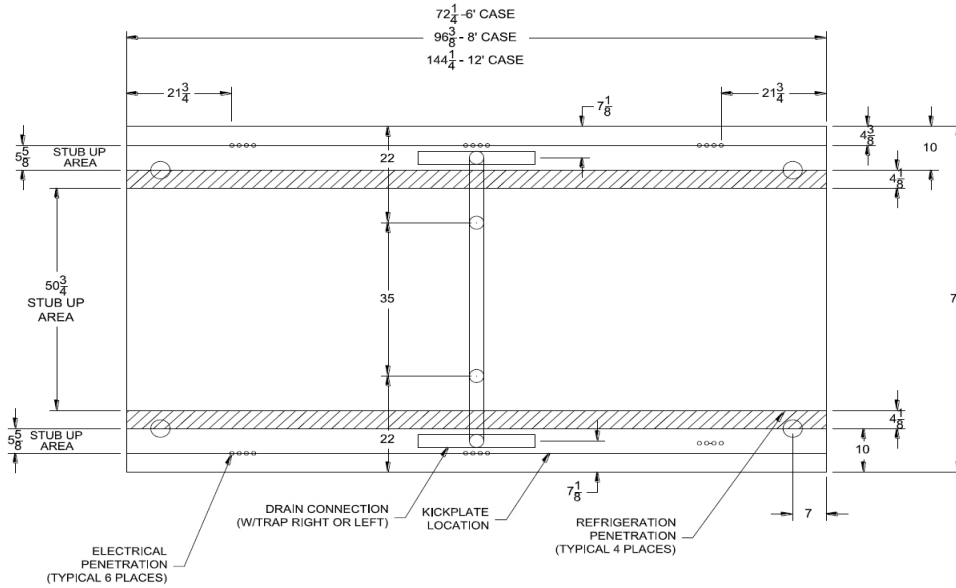

5201 Transport Blvd
Columbus, GA 31907
P: 800.866.5596 • F: 706.568.8990



www.kysorwarren.com

