

# SX1XN -- STRATUS Multi-Deck

Issue Date: 11/16/2012



## Capacities

Length (FT)	Facing Area (FT <sup>2</sup> )	Cubic Capacity (FT <sup>3</sup> )
4	12.28	7.047
6	18.39	10.55
8	24.54	14.07
12	36.79	21.105

## Refrigeration Data

BTUH per FT of Case Unlighted Shelves - One Row Canopy - LED Lights		BTUH per FT of Case Unlighted Shelves - One Row Canopy - T8 Lights		Add BTUH per FT per Row Lighted Shelves		Add BTUH per FT per Row Nose Lights or Additional T8 Canopy Light		Evap. Temp.	Discharge Air	
Parallel	Single	Parallel	Single	LED	T8	LED	T8		Temp	Velocity
890	961	N/A	N/A	11	19	11	19	+26°F	+33°F	200 FPM

Add 13 BTUH/FT for additional LED canopy light

## Electrical Data

Length	ECM Fan Data		Shelf Light Amps Per Lighted Shelf		Nose Light Amps per Lighted Shelf		Canopy Light - Amps	
	Fan Qty	Amps	LED	T8	LED	T8	1 Row LED	2 Row T8
4'	1	0.1	0.12	0.25	0.1	0.25	0.24	0.5
6'	2	0.2	0.09	0.22	0.18	0.44	0.37	0.88
8'	2	0.2	0.12	0.25	0.2	0.5	0.48	1
12'	4	0.4	0.12	0.25	0.36	0.75	0.72	1.5

## Defrost Data

Defrost	Per Day	Fail Safe	Termination
Off Cycle	6	18 min	+50°F

Type I refrigerator, intended for use in an area where the environmental conditions are controlled and maintained that conditions do not exceed 75°F and 55% relative humidity. Heatcraft Worldwide Refrigeration, whose policy is one of continuous improvement, reserves the right to change at any time specifications, designs, or prices without incurring obligation.



The above case model has case lengths that are UL and NSF approved.



Merchandising Applications

SX1XN Cross View

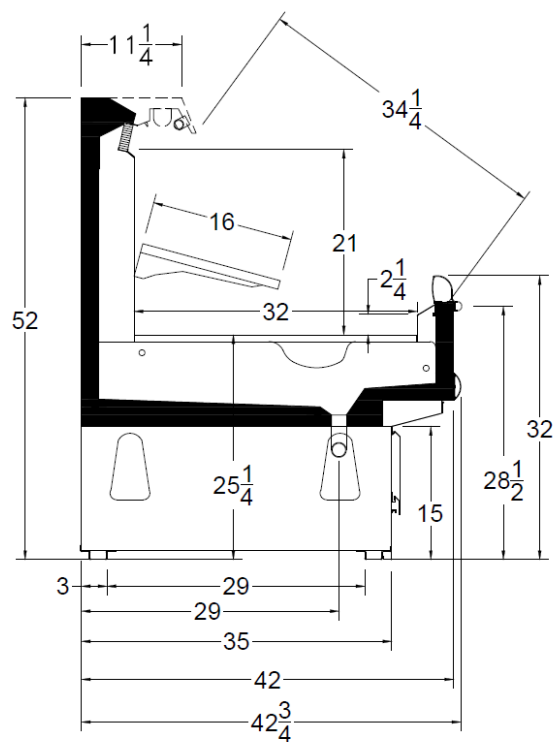

Add 3" thickness for a pair of ends.

SX1XN Plan View

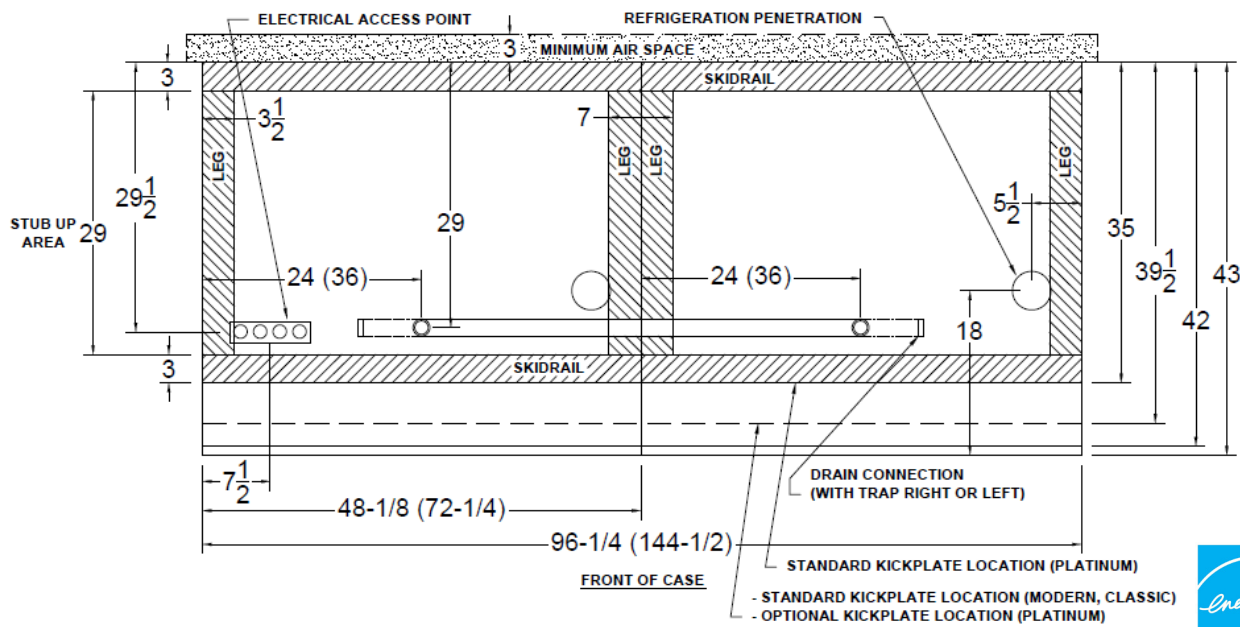

**KYSOR/WARREN®**

5201 Transport Blvd. • Columbus, GA 31907  
 P: 800.866.5596 • F: 706.568.8990  
 kysorwarren.com



A Proud Partner of:

