

SX2LN - STRATUS

MULTI-DECK SPECIFICATION SHEET



General Case Data	Case Length (ft)			
	4'	6'	8'	12'
Total Display Area (ft ²)	12.31	18.43	24.59	36.87
Cubic Capacity (ft ³)	11.89	17.83	23.78	35.67
Max Shelf Depth (in) [Top/Bottom]	12/16	12/16	12/16	12/16
Weight (lb)	-	-	-	-
Thermal Load (General)				
Discharge Air Velocity (fpm)	200	200	200	200
Fan Speed (rpm)	1100	1100	1100	1100
Discharge Air Temp (°F)	31	31	31	31
Conventional Thermal Load, Single (Btuh) one row of canopy LED	3812	5718	7624	11436
Parallel Thermal Load, Single (Btuh) one row of canopy LED	3530	5295	7060	10590
Additional Btuh per ft LED - Canopy / Shelf & Nose	13 / 11	13 / 11	13 / 11	13 / 11
Thermal Load (HFC)				
Evaporator Temperature (°F)	26	26	26	26
Superheat Setpoint (°F)	6 - 8	6 - 8	6 - 8	6 - 8
Estimated Refrigerant Charge (lbs)	1.241	1.846	2.579	3.925
Thermal Load (Glycol)				
Supply Temperature (°F)	20	20	20	20
Flow (GPM)	QTE	QTE	QTE	QTE
Fluid %	35	35	35	35
Pressure Drop (PSID)	QTE	QTE	QTE	QTE
Electrical Data (Amps/Watts)				
115V/60Hz, 1 Phase				
Fans	0.10	0.19	0.19	0.29
Canopy Lights (Per row)				
GE LED	0.22	0.33	0.44	0.67
Shelf Lights (Per row)				
GE LED	0.08	0.10	0.15	0.23

Defrost Data (off Cycle)			
Defrosts per Day	Failsafe Duration (min) ¹	Termination Temp (°F)	Drip Time (min)
6	18	50	2

¹ At ASHRAE conditions. For conditions above 75°F, 55% RH, increase defrost time by 15 min. Type I refrigerator, intended for use in an area where the environmental conditions are controlled and maintained that conditions do not exceed 75°F and 55% relative humidity. Kysor Warren, whose policy is one of continuous improvement, reserves the right to change at any time specifications, designs, or prices without incurring obligation. DOE 2017 Compliant

APPLICATIONS



The above case model has case lengths that are UL and NSF approved.

SX2LN - STRATUS

MULTI-DECK SPECIFICATION SHEET

SX2LN CROSS VIEW

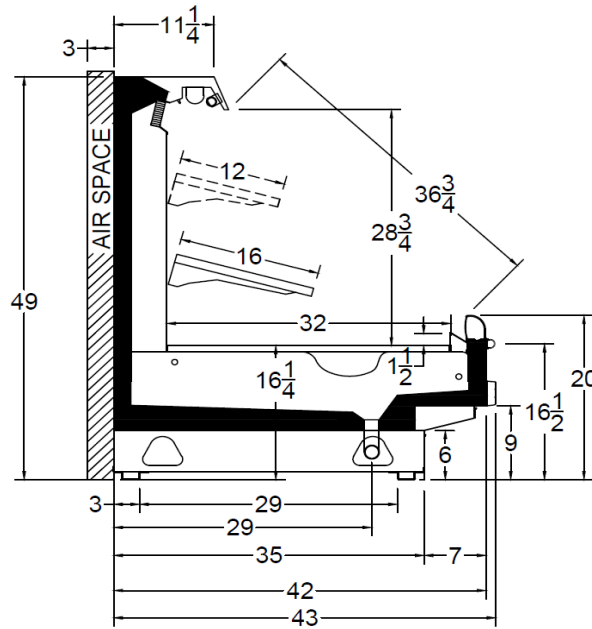

Add 3" thickness for a pair of ends.

SX2LN PLAN VIEW (Single Coil)

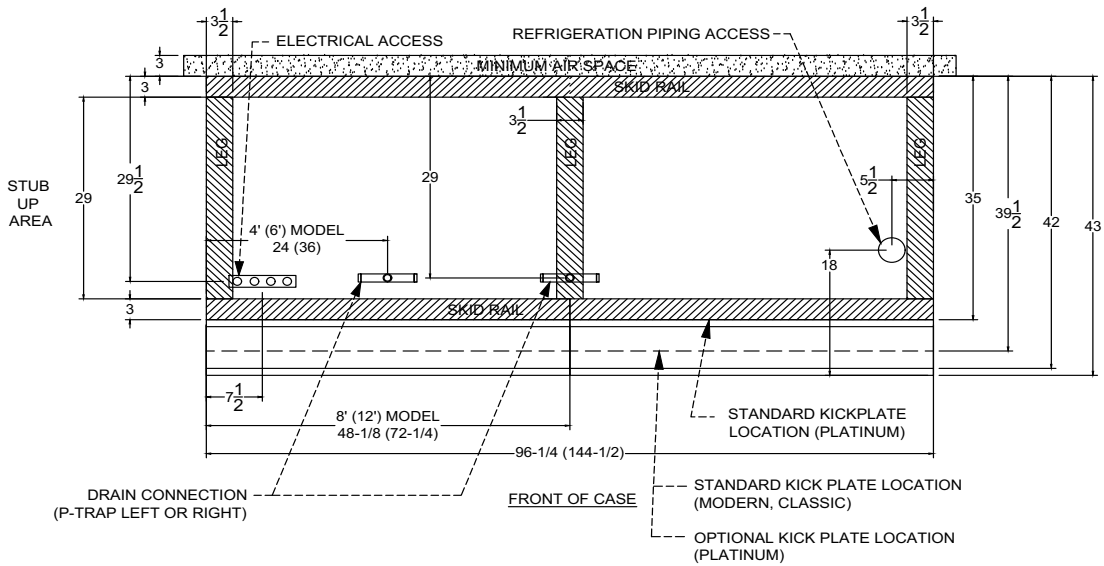

5201 Transport Blvd
Columbus, GA 31907
P: 800.866.5596 • F: 706.568.8990



www.kysorwarren.com



KYSOR WARREN
epta refrigeration